



## Multi Inverter Outdoor

Service Manual

New Released

Form: MMULIT50-191127

# Multi Inverter R-410A 50Hz Heat Pump

YU2E14YEEMHO-X  
YU2E18YEEMHO-X  
YU3E21YEEMHO-X  
YU3E27YEEMHO-X  
YU4E28YEEMHO-X  
YU4E36YEEMHO-X  
YU5E42YEEMHO-X



Issue Date  
Nov 27, 2019

# CONTENTS

<b>1. General information of Outdoor Units .....</b>	<b>2</b>
<b>2. Features .....</b>	<b>3</b>
<b>3. Dimensions.....</b>	<b>4</b>
<b>4. Refrigeration Cycle Diagram.....</b>	<b>5</b>
<b>5. Wiring diagram .....</b>	<b>7</b>
<b>6. Indoor units combination .....</b>	<b>12</b>
<b>7. Sound Levels.....</b>	<b>14</b>
<b>8. Installation Details .....</b>	<b>15</b>
<b>9. Electronic control function .....</b>	<b>25</b>
<b>10. Troubleshooting.....</b>	<b>30</b>

## 1. General information of Outdoor Units

<b>Model name</b>	<b>Dimension (mm)</b>	<b>Compressor</b>
YU2E14YEEMHO-X	800x333x554	KSN140D21UFZ
YU2E18YEEMHO-X	800x333x554	ASM135D23UFZ
YU3E21YEEMHO-X	845x363x702	ASM135D23UFZ
YU3E27YEEMHO-X	845x363x702	ATF235D22UMT
YU4E28YEEMHO-X	946x410x810	ATF235D22UMT
YU4E36YEEMHO-X	946x410x810	ATF310D43UMT
YU5E42YEEMHO-X	946x410x810	ATF310D43UMT

## 2. Features

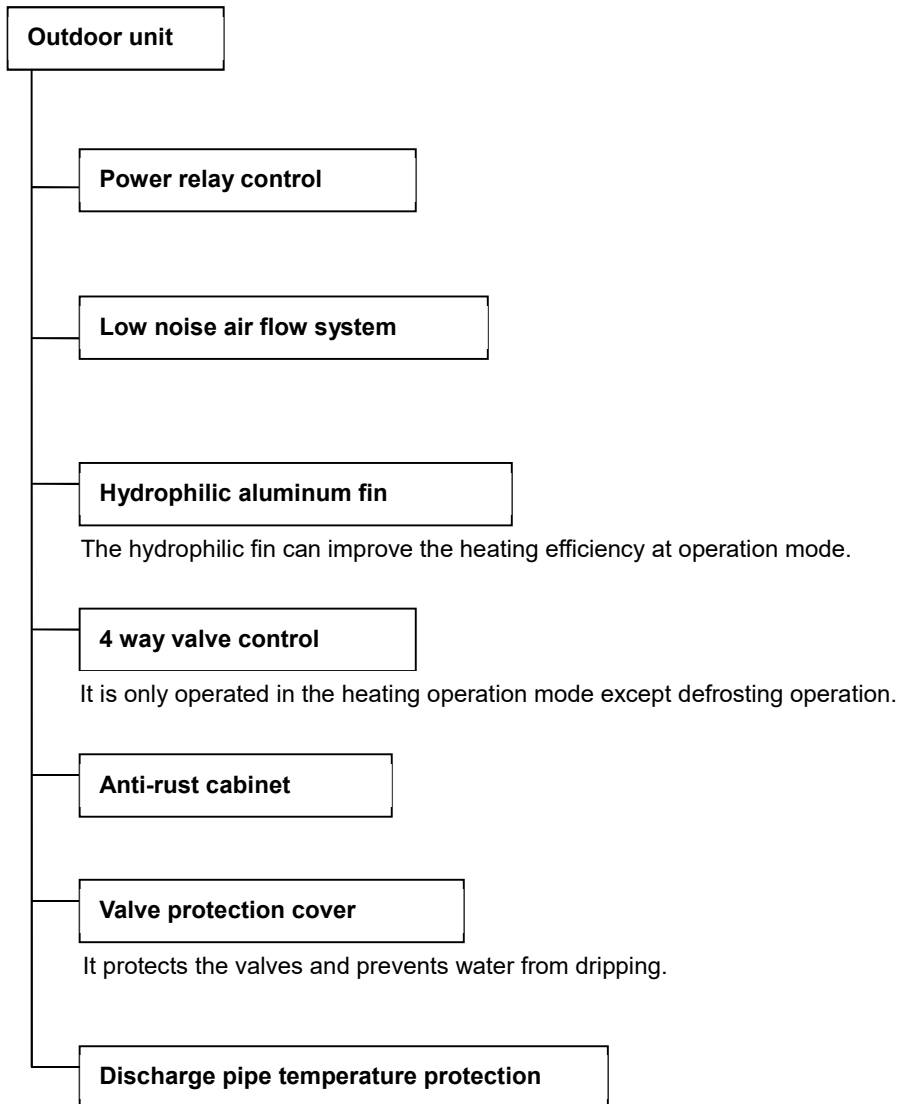

### 3. Dimensions

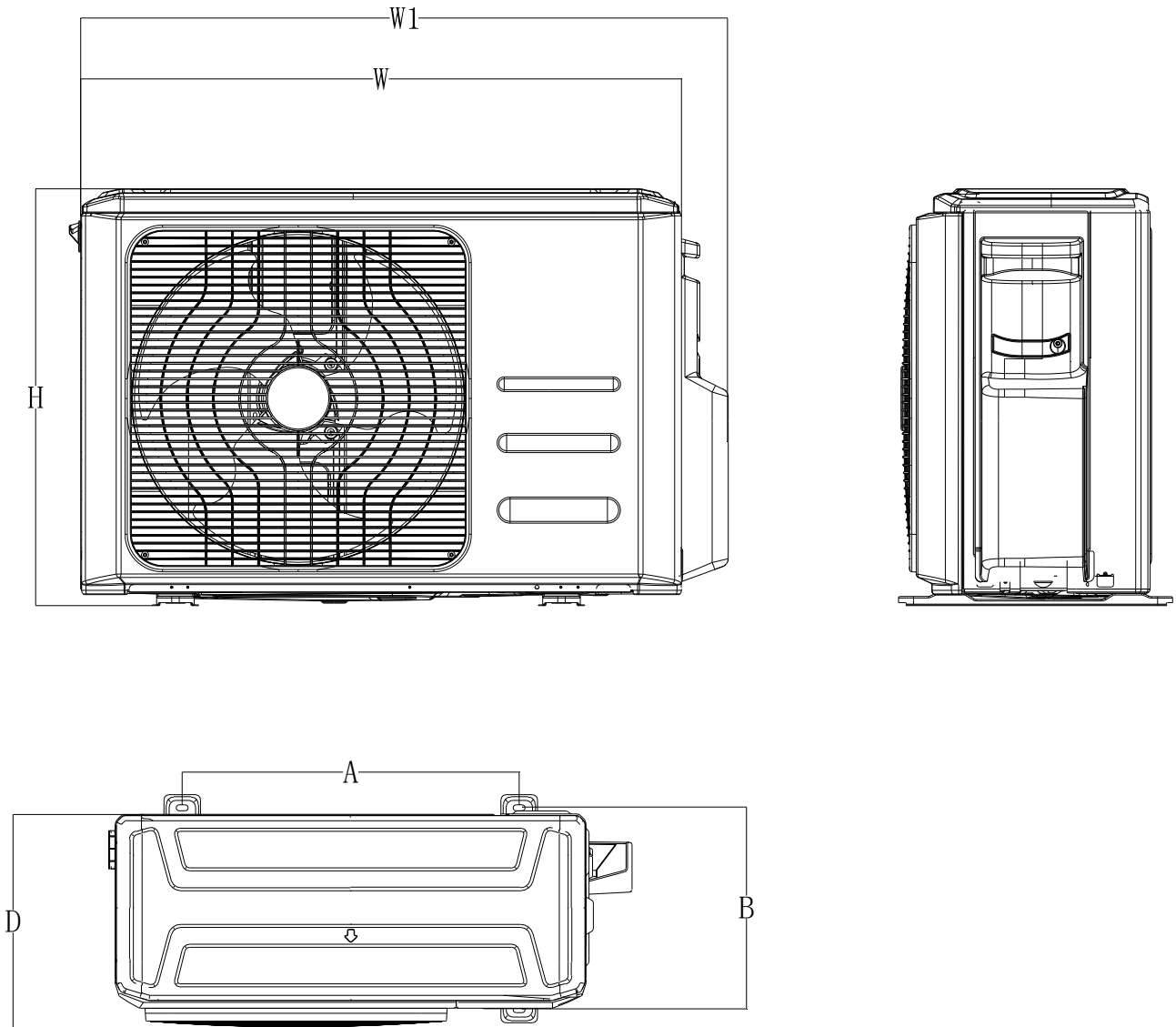

Model	Unit: mm					
	W	D	H	W1	A	B
YU2E14YEEMHO-X	800	333	554	860	514	340
YU2E18YEEMHO-X	800	333	554	860	514	340
YU3E21YEEMHO-X	845	363	702	923	540	350
YU3E27YEEMHO-X	845	363	702	923	540	350
YU4E28YEEMHO-X	946	410	810	1034	673	403
YU4E36YEEMHO-X	946	410	810	1034	673	403
YU5E42YEEMHO-X	946	410	810	1034	673	403

# 4. Refrigeration Cycle Diagram

## 4.1 Refrigeration circuit drawing of inverter 1 drive 2 type

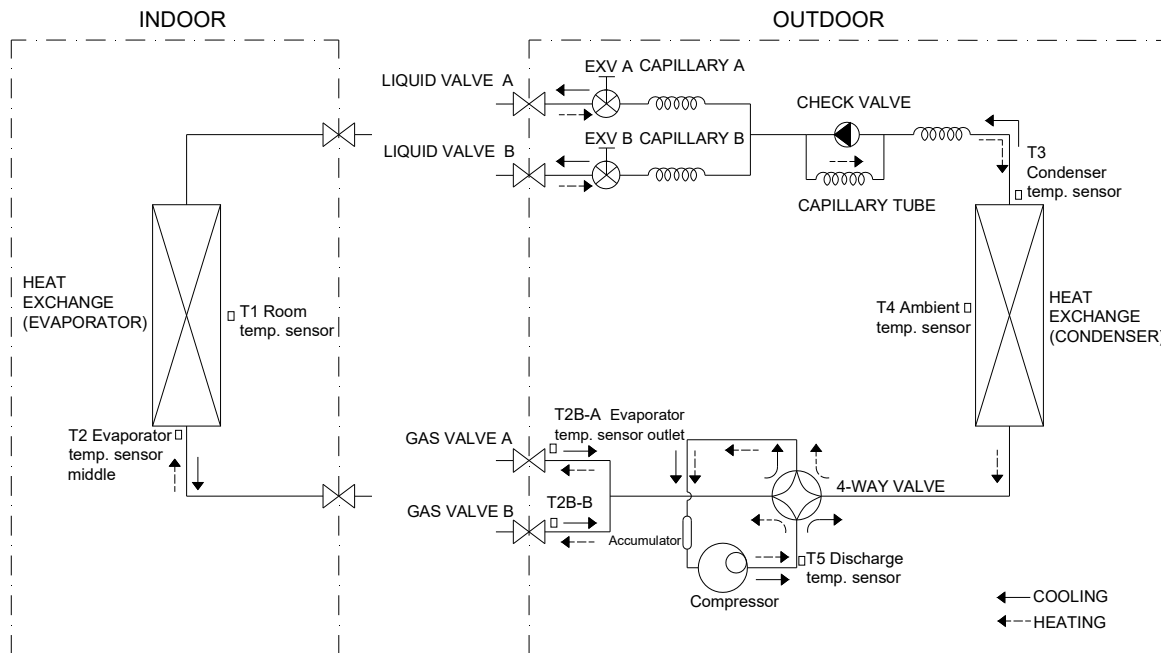

## 4.2 Refrigeration circuit drawing of inverter 1 drive 3 type

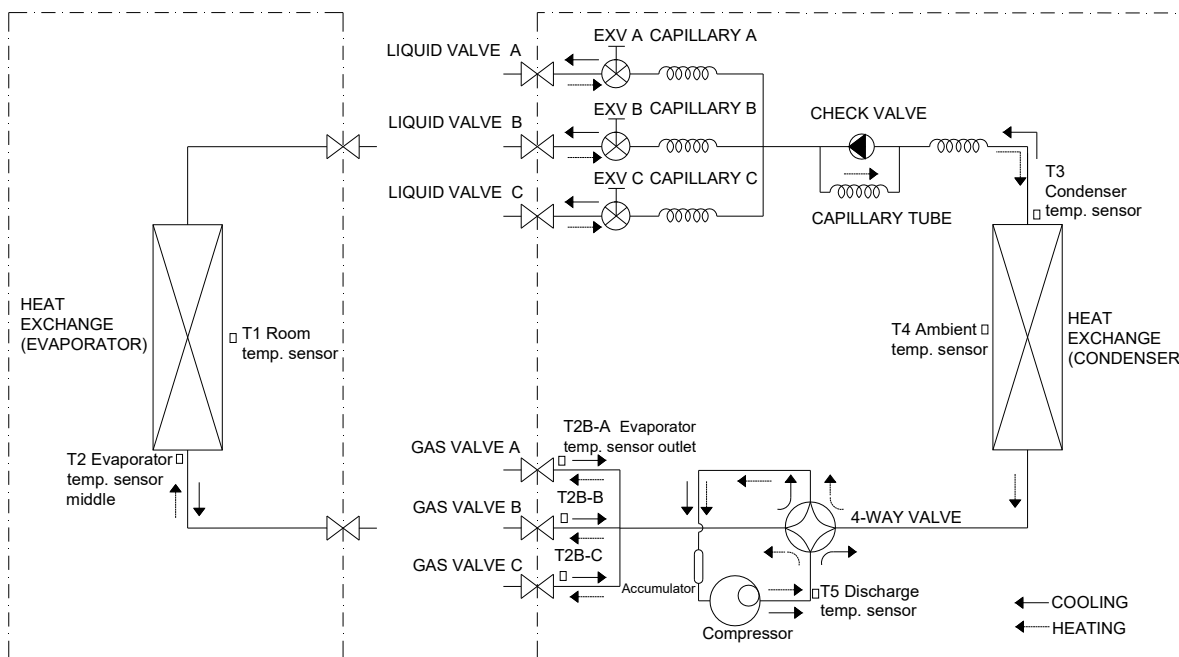

### 4.3 Refrigeration circuit drawing of inverter 1 drive 4 type

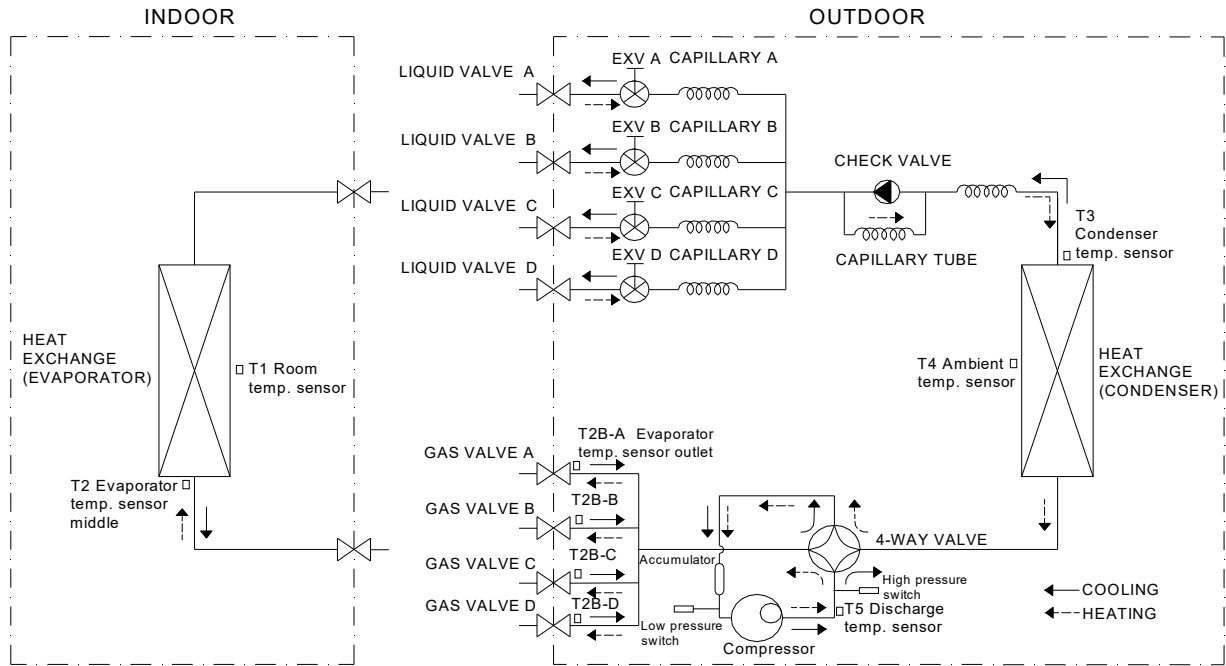

### 4.4 Refrigeration circuit drawing of inverter 1 drive 5 type

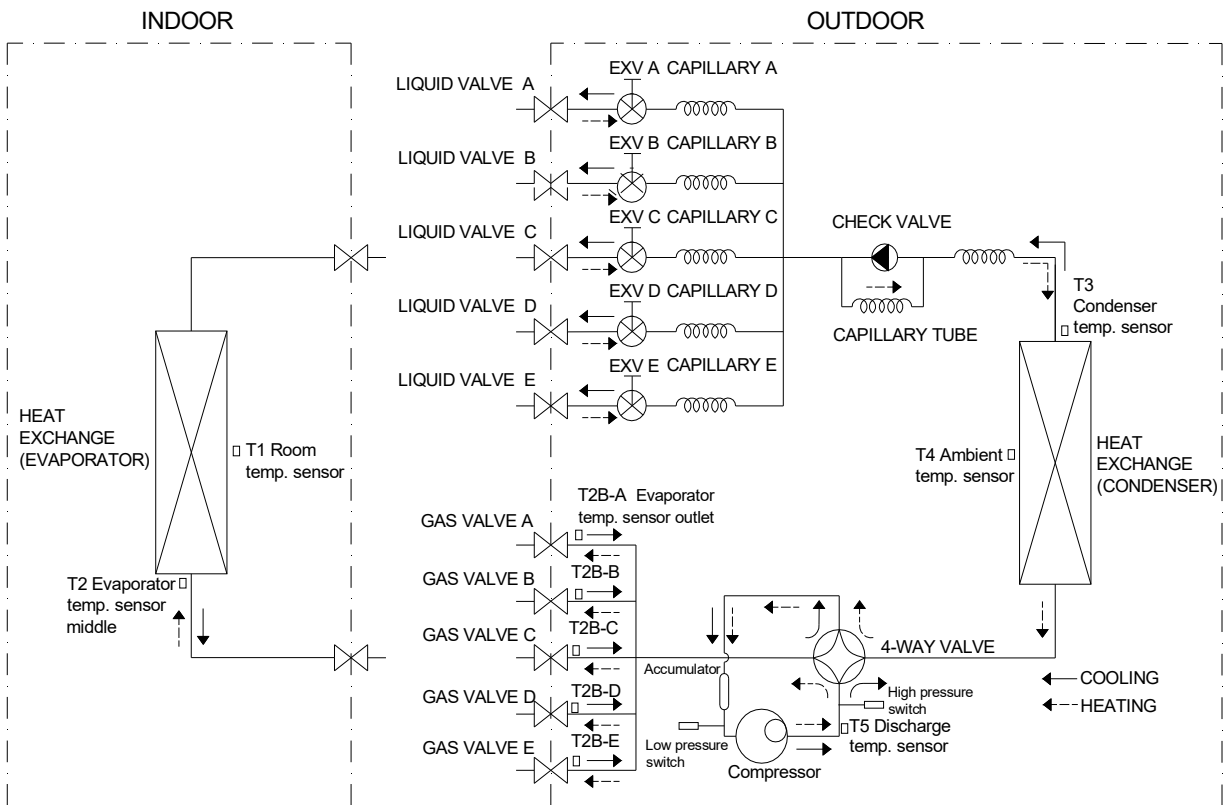

# 5. Wiring diagram

YU2E14YEEBMHO-X, YU2E18YEEBMHO-X

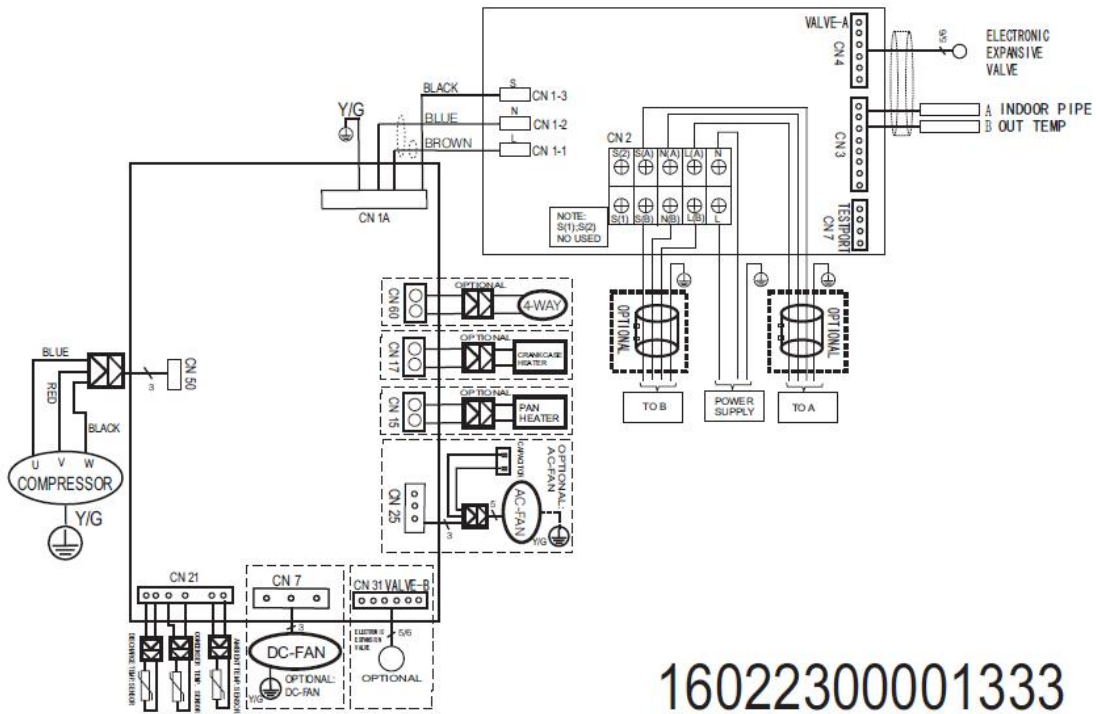

16022300001333

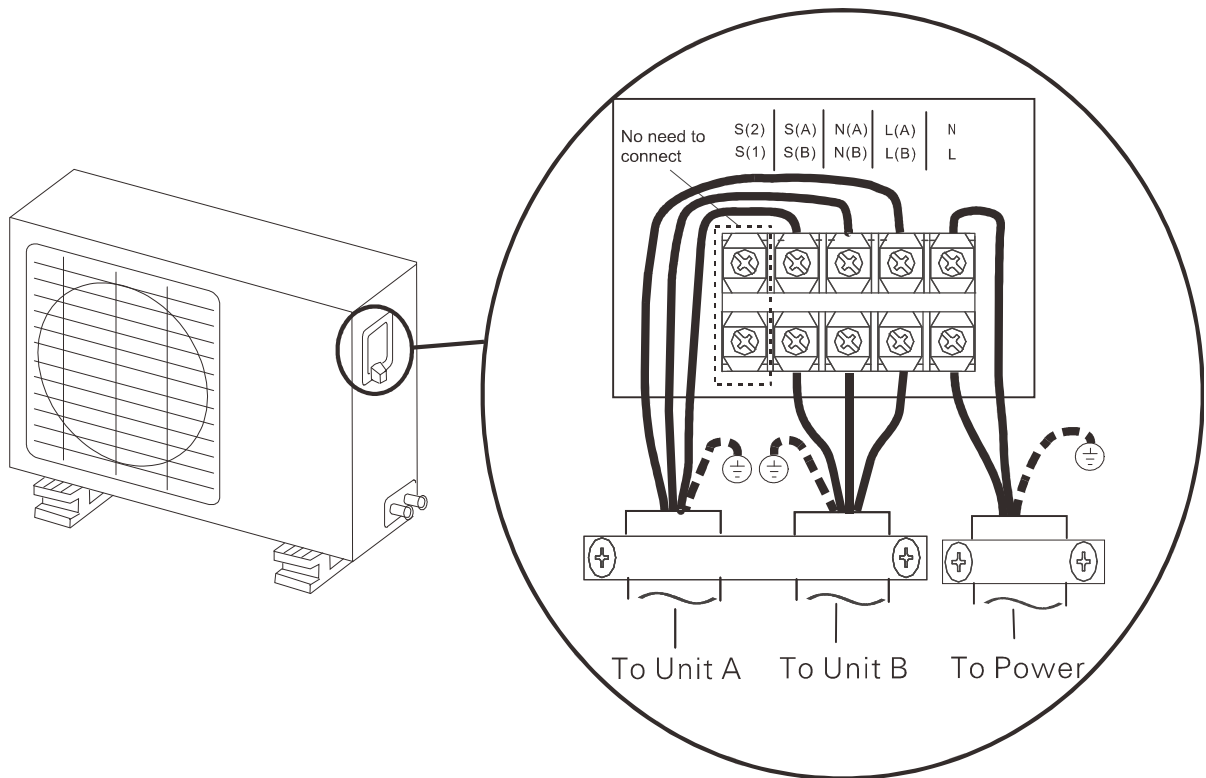



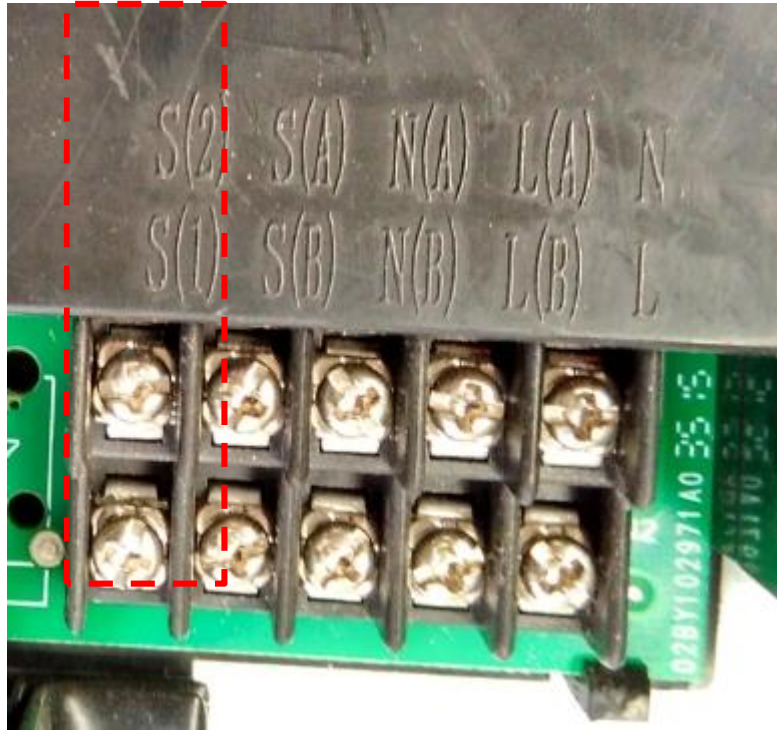

Note: S(1)&S(2) are used in other type of models. They don't need to be connected in multi models.

**YU3E21YEEMHO-X, YU3E27YEEMHO-X**

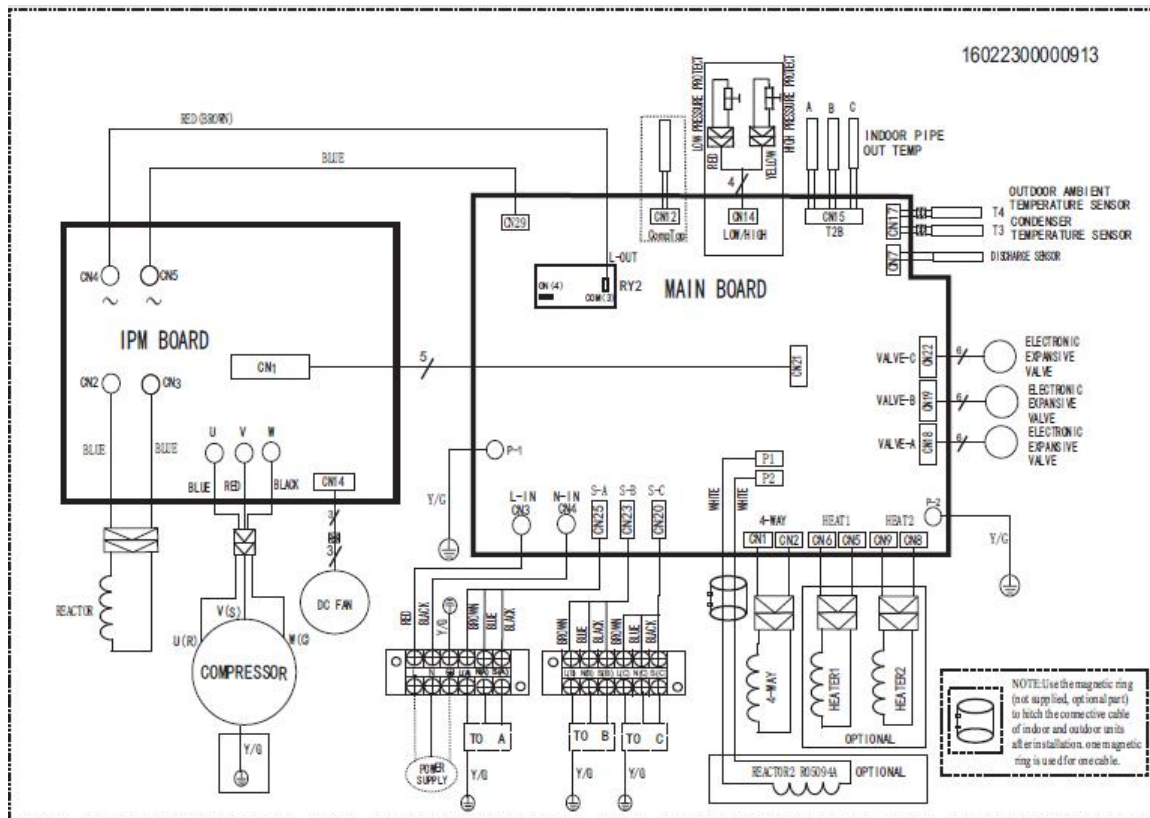



# YU4E28YEEMHO-X

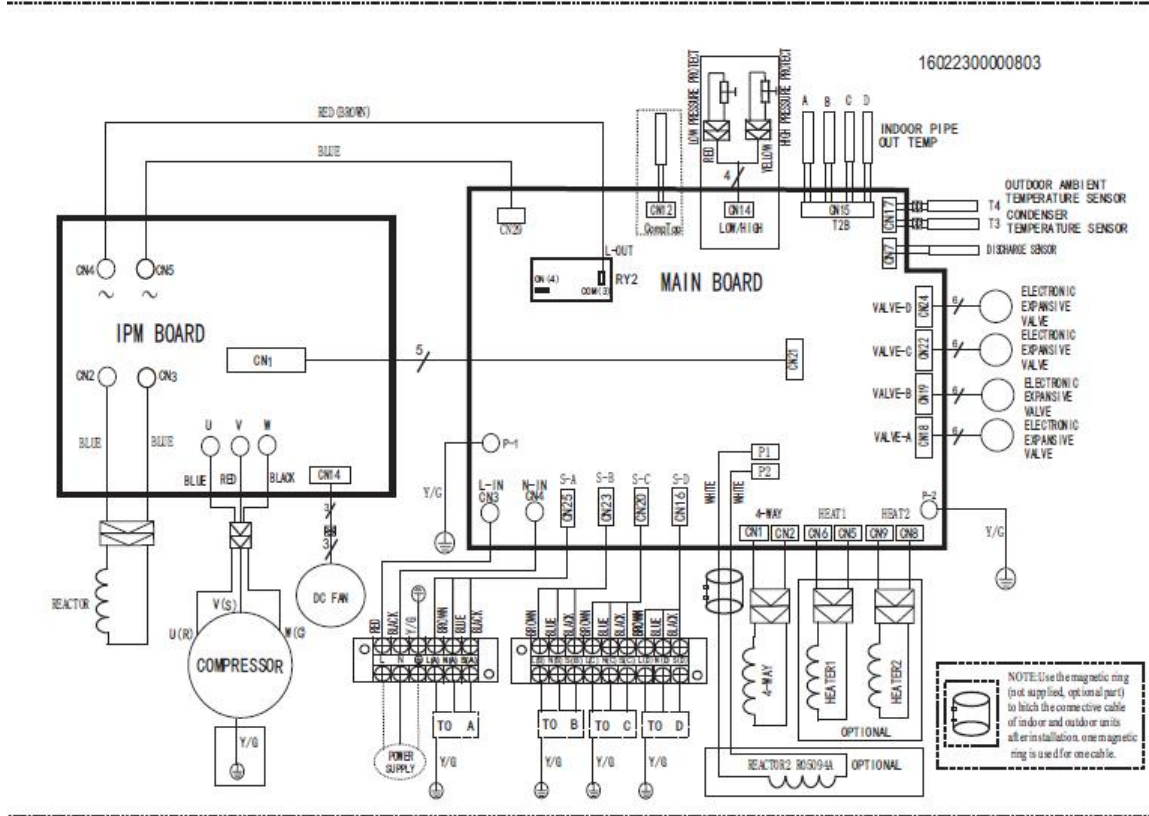

# YU4E36YEEMHO-X

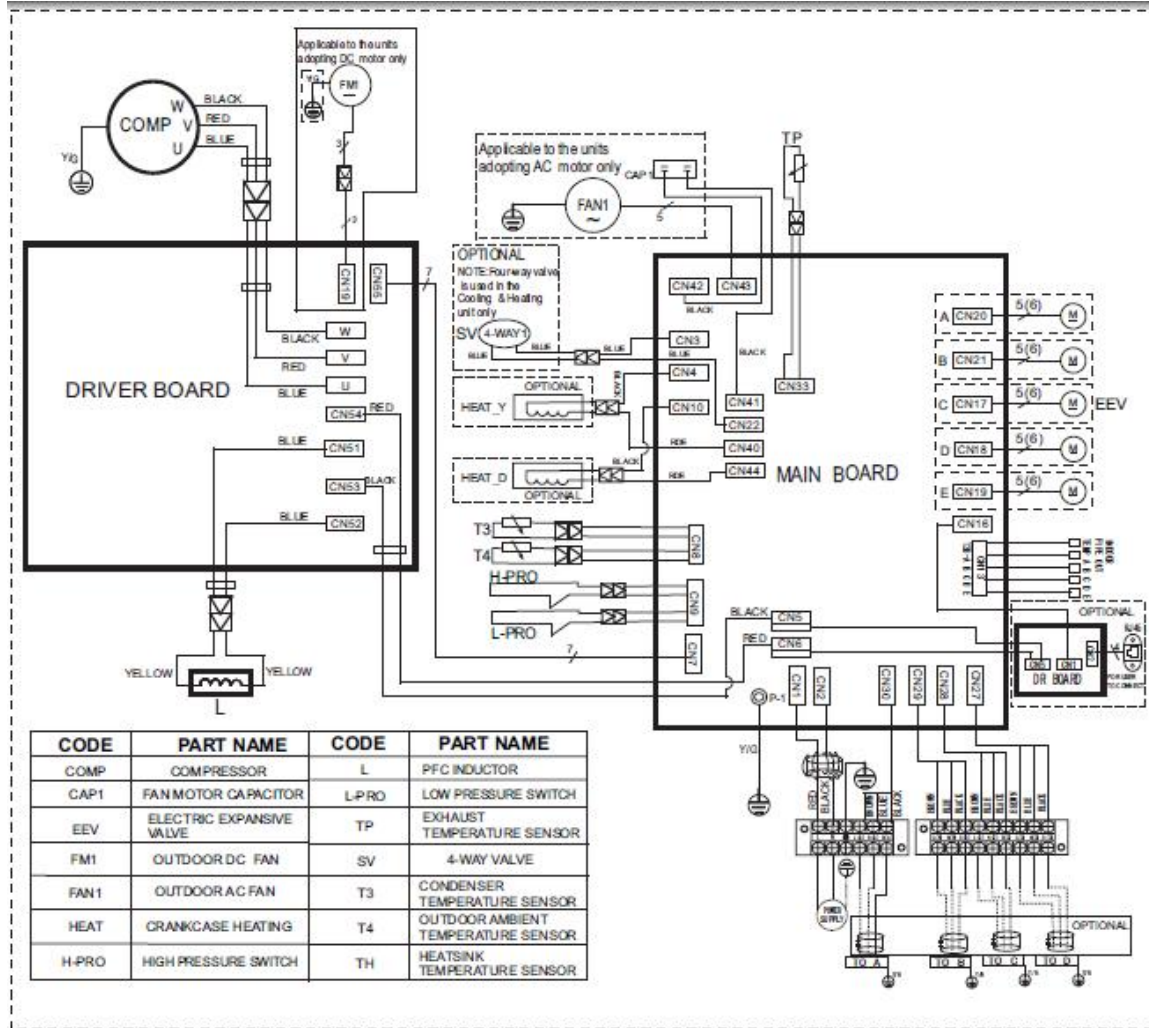

# YU5E42YEEMHO-X

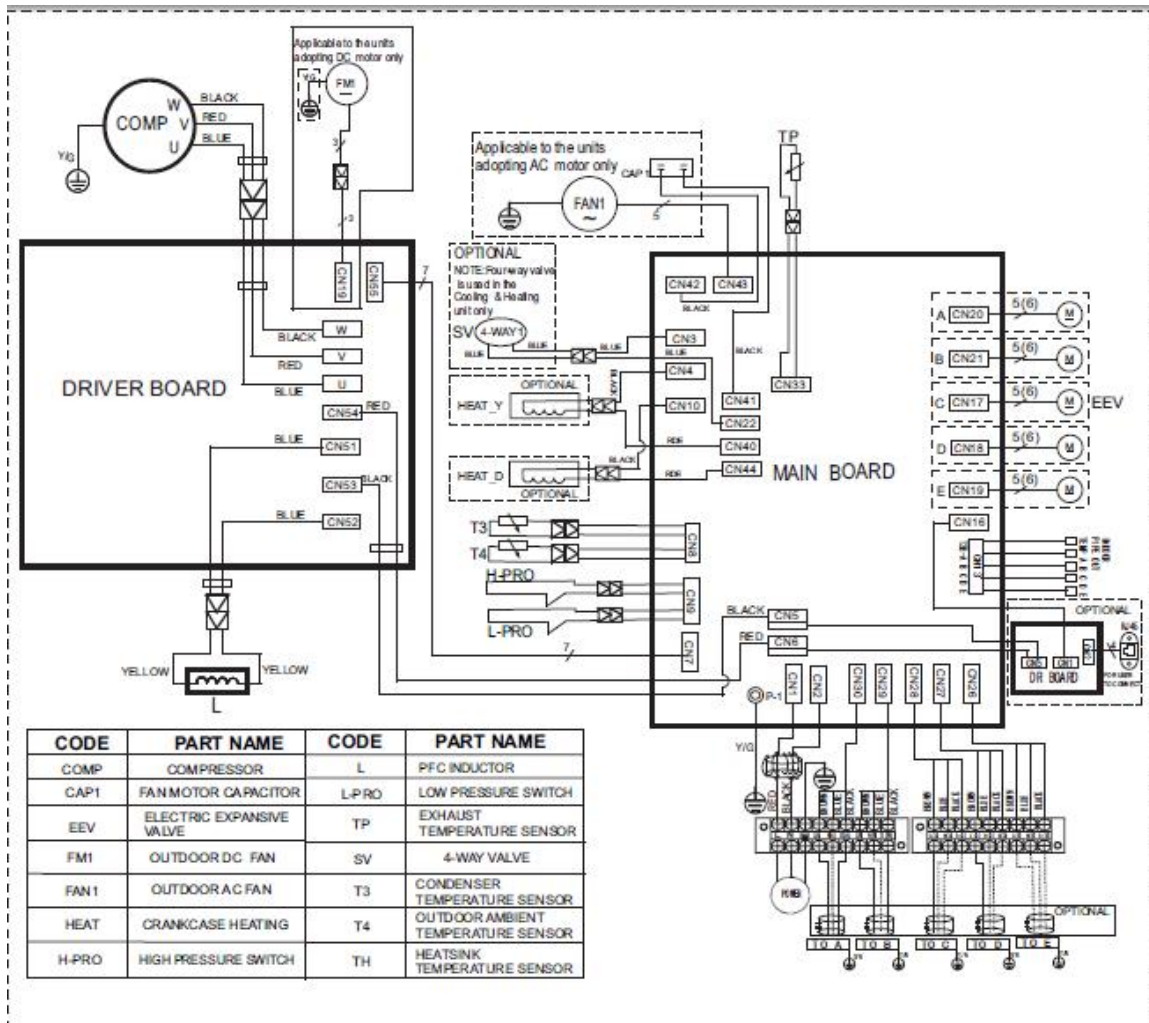

## 6. Indoor units combination

### 6.1 Indoor unit combination for YU2E14YEEMHO-X

One unit	Two unit	
7	7+7	9+9
9	7+9	9+12
12	7+12	
18		

### 6.2 Indoor unit combination for YU2E18YEEMHO-X

One unit	Two unit	
7	7+7	9+9
9	7+9	9+12
12	7+12	12+12
18		

### 6.3 Indoor unit combination for YU3E21YEEMHO-X

One unit	Two unit		Three unit	
7	7+7	9+9	7+7+7	7+9+9
9	7+9	9+12	7+7+9	9+9+9
12	7+12	9+18	7+7+12	
18	7+18	12+12		

### 6.4 Indoor unit combination for YU3E27YEEMHO-X

One unit	Two unit			Three unit		
7	7+7	7+18	9+18	7+7+7	7+9+12	9+12+12
9	7+9	9+9	12+12	7+7+9	7+12+12	12+12+12
12	7+12	9+12	12+18	7+7+12	9+9+9	
18				7+9+9	9+9+12	

### 6.5 Indoor unit combination for YU4E28YEEMHO-X

One unit	Two unit			Three unit			Four unit	
7	7+7	9+9	12+18	7+7+7	7+9+12	9+9+18	7+7+7+7	7+7+9+12
9	7+9	9+12	12+24	7+7+9	7+9+18	9+12+12	7+7+7+9	7+9+9+9
12	7+12	9+18	18+18	7+7+12	7+12+12	12+12+12	7+7+7+12	9+9+9+9
18	7+18	9+24		7+7+18	9+9+9		7+7+9+9	
24	7+24	12+12		7+9+9	9+9+12			

### 6.6 Indoor unit combination for YU4E36YEEBMHO-X

ne unit	Two unit		Three unit				Four unit			
7	7+7	9+18	7+7+7	7+9+12	7+18+18	9+12+18	7+7+7+7	7+7+9+12	7+9+9+12	9+9+9+12
9	7+9	9+24	7+7+9	7+9+18	9+9+9	9+12+24	7+7+7+9	7+7+9+18	7+9+9+18	9+9+9+18
12	7+12	12+12	7+7+12	7+9+24	9+9+12	9+18+18	7+7+7+12	7+7+12+12	7+9+12+12	9+9+12+12
18	7+18	12+18	7+7+18	7+12+12	9+9+18	12+12+12	7+7+7+18	7+7+12+18	7+12+12+12	9+12+12+12
24	7+24	12+24	7+7+24	7+12+18	9+9+24	12+12+18	7+7+9+9	7+9+9+9	9+9+9+9	12+12+12+12
	9+9	18+18	7+9+9	7+12+24	9+12+12					
	9+12									

### 6.7 Indoor unit combination for YU5E42YEEBMHO-X

One Unit	Two Unit		Three Unit			
7	7+7	9+18	7+7+7	7+9+18	9+9+12	12+12+12
9	7+9	9+24	7+7+9	7+9+24	9+9+18	12+12+18
12	7+12	12+12	7+7+12	7+12+12	9+9+24	12+12+24
18	7+18	12+18	7+7+18	7+12+18	9+12+12	12+18+18
24	7+24	12+24	7+7+24	7+12+24	9+12+18	
	9+9	18+18	7+9+9	7+18+18	9+12+24	
	9+12		7+9+12	9+9+9	9+18+18	
Four Unit						
	7+7+7+7	7+7+9+18	7+9+9+12	7+12+12+12	9+9+12+18	
	7+7+7+9	7+7+9+24	7+9+9+18	7+12+12+18	9+9+12+24	
	7+7+7+12	7+7+12+12	7+9+9+24	9+9+9+9	9+12+12+12	
	7+7+7+18	7+7+12+18	7+9+12+12	9+9+9+12	9+12+12+18	
	7+7+7+24	7+7+12+24	7+9+12+18	9+9+9+18	12+12+12+12	
	7+7+9+9	7+7+18+18	7+9+12+24	9+9+9+24	12+12+12+18	
	7+7+9+12	7+9+9+9	7+9+18+18	9+9+12+12		
Five Unit						
	7+7+7+7+7	7+7+7+9+18	7+7+9+12+12	7+9+9+9+18	9+9+9+12+12	
	7+7+7+7+9	7+7+7+12+12	7+7+9+12+18	7+9+9+12+12	9+9+12+12+12	
	7+7+7+7+12	7+7+7+12+18	7+7+12+12+12	7+9+12+12+12		
	7+7+7+7+18	7+7+9+9+9	7+7+12+12+18	9+9+9+9+9		
	7+7+7+9+9	7+7+9+9+12	7+9+9+9+9	9+9+9+9+12		
	7+7+7+9+12	7+7+9+9+18	7+9+9+9+12	9+9+9+9+18		

## 7. Sound Levels

Outdoor Unit

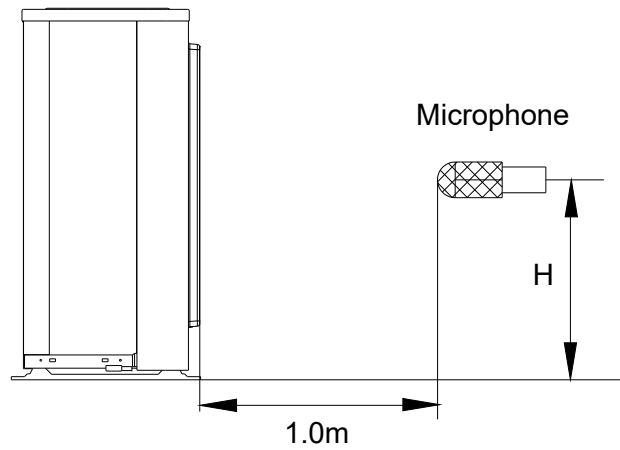

**Note:**  $H = 0.5 \times \text{height of outdoor unit}$

Model	Noise Power dB(A)	Noise level dB(A)
YU2E14YEEBMHO-X	64	54
YU2E18YEEBMHO-X	65	56.5
YU3E21YEEBMHO-X	65	57.5
YU3E27YEEBMHO-X	68	59.5
YU4E28YEEBMHO-X	66	60
YU4E36YEEBMHO-X	68	63.5
YU5E42YEEBMHO-X	68	62

## 8. Installation Details

### 8.1 Wrench torque sheet for installation

Outside diameter	Torque	Additional tightening torque
mm	N.cm	N.cm
Φ6.35	1500(153kgf.cm)	1600(163kgf.cm)
Φ9.52	2500(255kgf.cm)	2600(265kgf.cm)
Φ12.7	3500(357kgf.cm)	3600(367kgf.cm)

### 8.2 Connecting the cables

The power cord of connect should be selected according to the following specifications sheet.

Rated current of appliance	Nominal cross-sectional area (mm <sup>2</sup> )
>3 and ≤6	0.75
>6 and ≤10	1
>10 and ≤16	1.5
>16 and ≤25	2.5

The cable size and the current of the fuse or switch are determined by the maximum current indicated on the nameplate which located on the side panel of the unit. Please refer to the nameplate before selecting the cable, fuse and switch.

### 8.3 Pipe length and the elevation

#### Maximum piping length and height difference

	1 drive 2	1 drive 3	1 drive 4	1 drive 5
Max. length for all rooms (m)	40	60	80	80
Max. length for one IU (m)	25	30	35	35
Max. height difference between IU and OU (m)	15	15	15	15
Max. height difference between IUs (m)	10	10	10	10

#### Additional refrigerant charge

	1 drive 2	1 drive 3	1 drive 4	1 drive 5
Chargeless pipe length (m)	15	22.5	30	37.5
Additional refrigerant charge (g)	15 x (length for all rooms - 15)	15 x (length for all rooms - 22.5)	15 x (length for all rooms - 30)	15 x (length for all rooms - 37.5)

Caution:

- Refrigerant pipe diameter is different according to indoor unit to be connected. When using the extension pipe, refer to the tables below.



- When refrigerant pipe diameter is different from that of outdoor unit union (for 18K&24K indoor unit), additional transfer connector needs to be used on outdoor unit union.

Indoor unit		Extension pipe diameter (mm/inch)		
Model	Pipe diameter (mm/inch)			
7K9K12K	Liquid	6.35(1/4)	Liquid	6.35(1/4)
	Gas	9.52(3/8)	Gas	9.52(3/8)
18K	Liquid	6.35(1/4)	Liquid	6.35(1/4)
	Gas	12.7(1/2)	Gas	12.7(1/2)
24K	Liquid	9.52(3/8)	Liquid	9.52(3/8)
	Gas	15.9(5/8)	Gas	15.9(5/8)
Outdoor unit union diameter (mm/inch)				
Indoor unit A/B/C/D/E		Liquid	6.35(1/4)	
		Gas	9.52(3/8)	
			12.7(1/2)	

#### 8.4 Installation for the first time

Air and moisture in the refrigerant system have undesirable effects as below:

- Pressure in the system rises.
- Operating current rises.
- Cooling or heating efficiency drops.
- Moisture in the refrigerant circuit may freeze and block capillary tubing.
- Water may lead to corrosion of parts in the refrigerant system.

Therefore, the indoor units and the pipes between indoor and outdoor units must be leak tested and evacuated to remove gas and moisture from the system.

Gas leak check (Soap water method):

Apply soap water or a liquid neutral detergent on the indoor unit connections or outdoor unit connections by a soft brush to check for leakage of the connecting points of the piping. If bubbles come out, the pipes have leakage.

##### 1. Air purging with vacuum pump

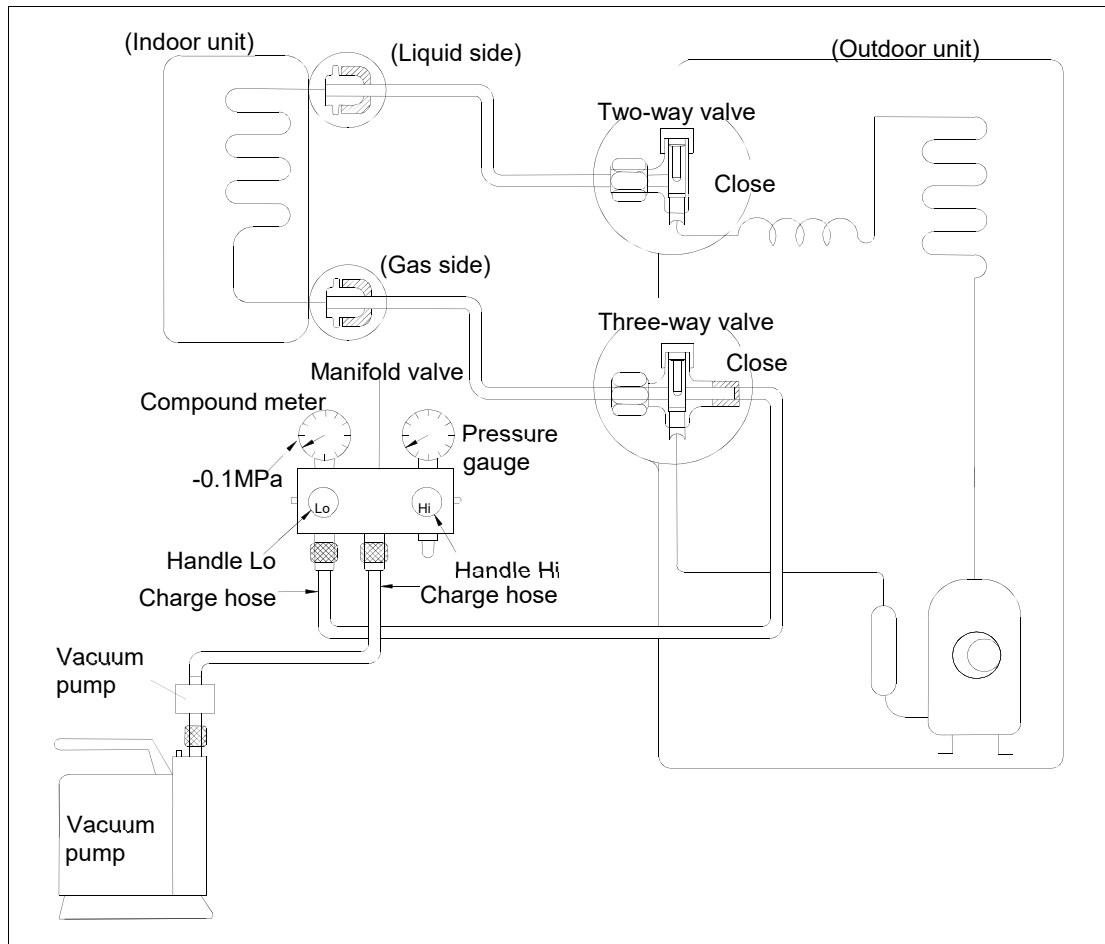

- 1) Completely tighten the flare nuts of the indoor and outdoor units, confirm that both the 2-way and 3-way valves are set to the closed position.
- 2) Connect the charge hose with the push pin of handle lo to the 3-way valves gas service port..
- 3) Connect the charge hose of handle hi connection to the vacuum pump.
- 4) Fully open the handle Lo of the manifold valve.
- 5) Operate the vacuum pump to evacuate.
- 6) Make evacuation for 30 minutes and check whether the compound meter indicates -0.1Mpa. If the meter does not indicate -0.1Mpa after pumping 30 minutes, it should be pumped 20 minutes more. If the pressure can't achieve -0.1Mpa after pumping 50 minutes, please check if there are some leakage points. Fully close the handle Lo valve of the manifold valve and stop the operation of the vacuum pump. Confirm that the gauge needle does not move (approximately 5 minutes after turning off the vacuum pump).
- 7) Turn the flare nut of the 3-way valves about 45° counterclockwise for 6 or 7seconds after the gas coming out, then tighten the flare nut again. Make sure the pressure display in the pressure indicator is a little higher than the atmosphere pressure. Then remove the charge hose from the 3 way valve.
- 8) Fully open the 2 way valve and 3 way valve and securely tighten the cap of the 3 way valve.

## 2. Air purging by refrigerant

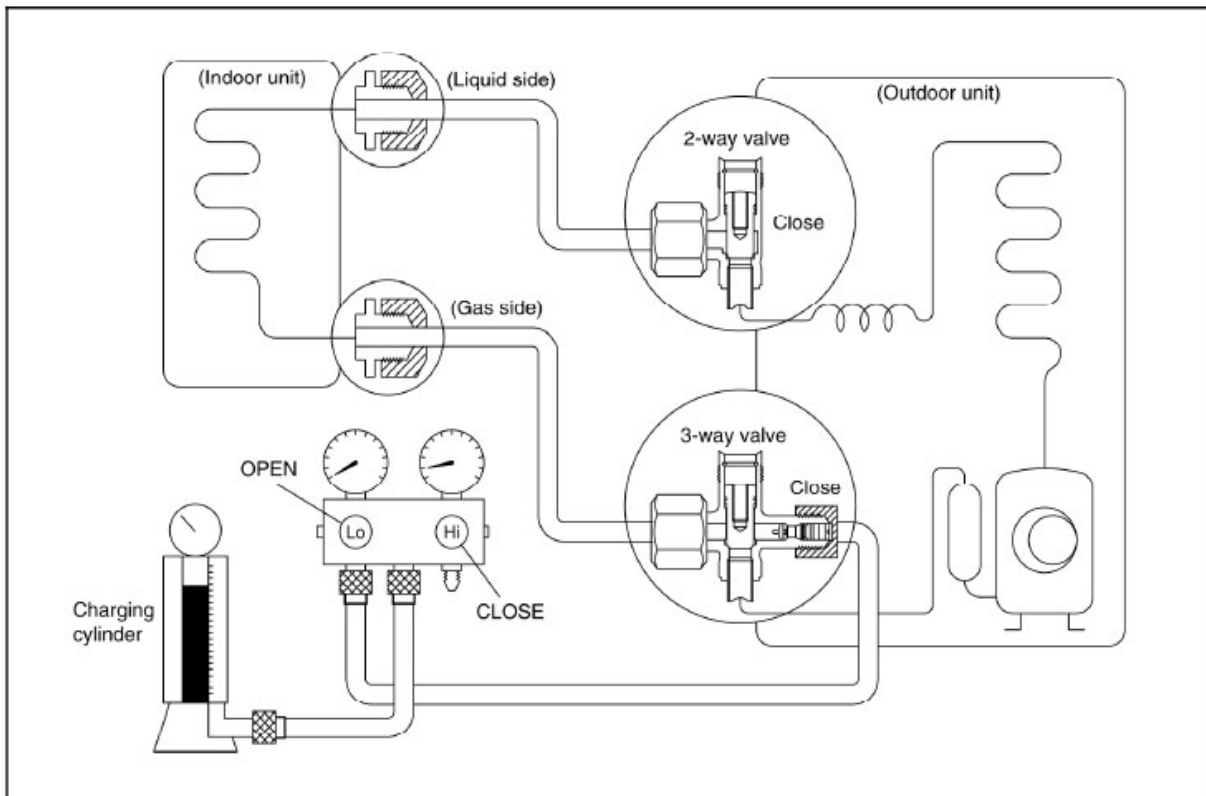

### Procedure:

- 1). Confirm that both the 2-way and 3-way valves are set to the closed position.
- 2). Connect the charge set and a charging cylinder to the service port of the 3-way valve.
- 3). Air purging.  
Open the valves on the charging cylinder and the charge set. Purge the air by loosening the flare nut on the 2-way valve approximately 45° for 3 seconds then closing it for 1 minute; repeat 3 times.  
After purging the air, use a torque wrench to tighten the flare nut on the 2-way valve.
- 4). Check the gas leakage.  
Check the flare connections for gas leakage.
- 5). Discharge the refrigerant.  
Close the valve on the charging cylinder and discharge the refrigerant by loosening the flare nut on the 2-way valve approximately 45° until the gauge indicates 0.3 to 0.5 Mpa.
- 6). Disconnect the charge set and the charging cylinder, and set the 2-way and 3-way valves to the open position.  
Be sure to use a hexagonal wrench to operate the valve stems.
- 7). Mount the valve stems nuts and the service port cap.  
Be sure to use a torque wrench to tighten the service port cap to a torque 18N·m.  
Be sure to check the gas leakage.

### 3. Adding the refrigerant if the pipe length >5m

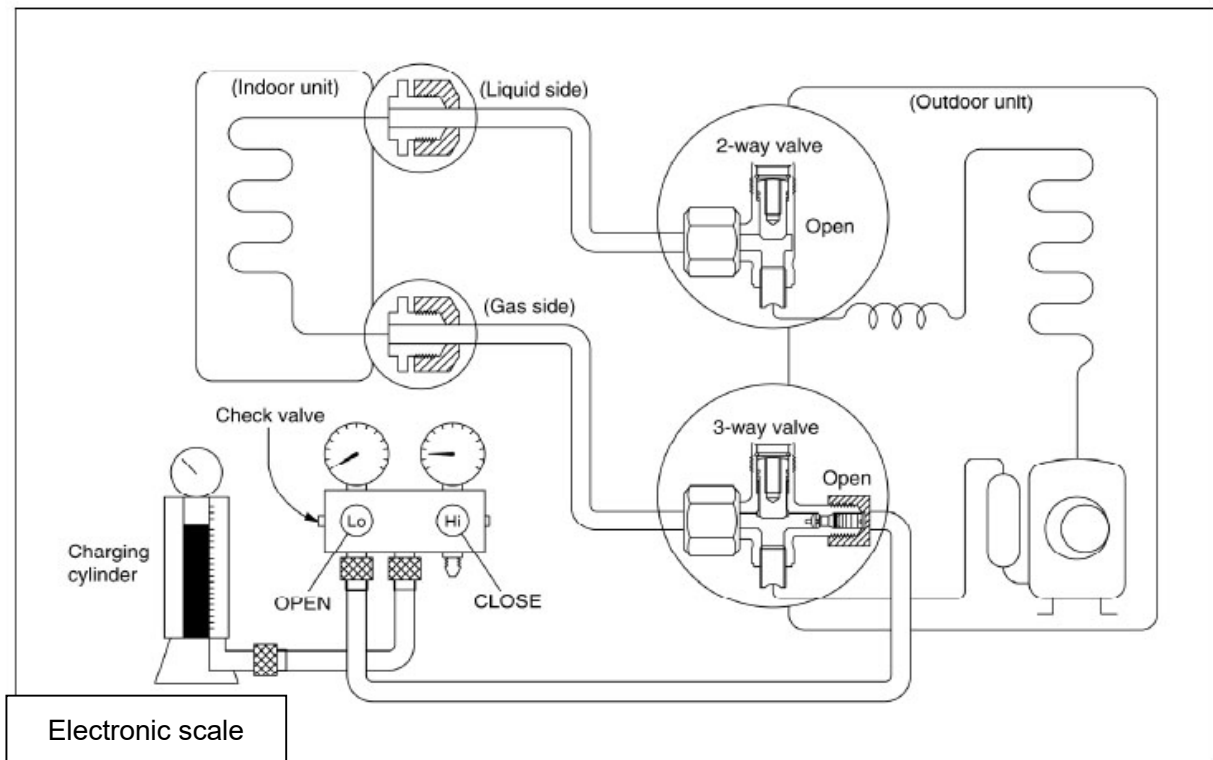

#### Procedure:

1). Connect the charge hose to the charging cylinder, open the 2-way valve and the 3-way valve.

Connect the charge hose which you disconnected from the vacuum pump to the valve at the bottom of the cylinder. If the refrigerant is R410A, make the cylinder bottom up to ensure the liquid charge.

2). Purge the air from the charge hose.

Open the valve at the bottom of the cylinder and press the check valve on the charge set to purge the air (be careful of the liquid refrigerant).

3) Put the charging cylinder onto the electronic scale and record the weight.

4) Operate the air conditioner at the cooling mode.

5) Open the valves (Low side) on the charge set and charge the system with liquid refrigerant.

6).When the electronic scale displays the proper weight (refer to the table), disconnect the charge hose from the 3-way valve's service port immediately and turn off the air conditioner before disconnecting the hose.

7). Mount the valve stem caps and the service port

Use torque wrench to tighten the service port cap to a torque of 18N.m.

Be sure to check for gas leakage.

## 8.5 Adding the refrigerant after running the system for many years

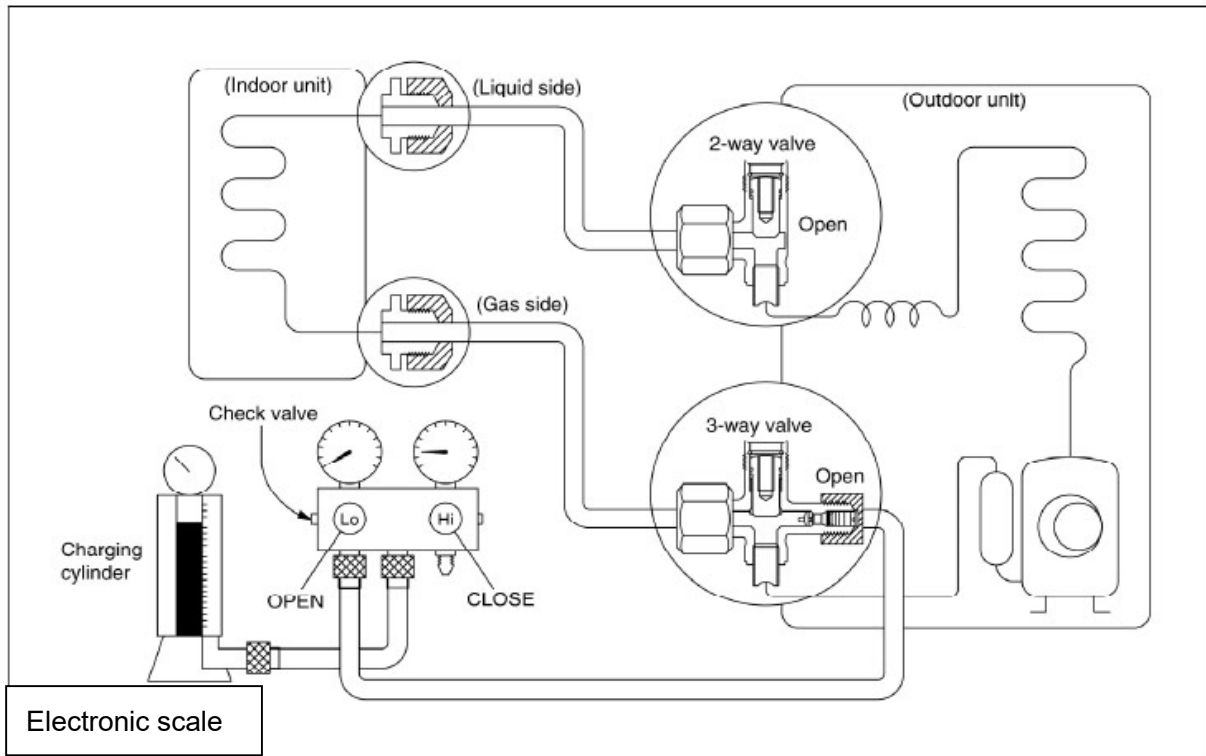

### Procedure:

- 1). Connect the charge hose to the 3-way service port, open the 2-way valve and the 3-way valve. Connect the charge hose to the valve at the bottom of the cylinder. If the refrigerant is R410A, make the cylinder bottom up to ensure liquid charge.
- 2). Purge the air from the charge hose.  
Open the valve at the bottom of the cylinder and press the check valve on the charge set to purge the air (be careful of the liquid refrigerant).
- 3) Put the charging cylinder onto the electronic scale and record the weight.
- 4) Operate the air conditioner at the cooling mode.
- 5) Open the valves (Low side) on the charge set and charge the system with liquid refrigerant.
- 6).When the electronic scale displays the proper weight (refer to the gauge and the pressure of the low side), disconnect the charge hose from the 3-way valve's service port immediately and turn off the air conditioner before disconnecting the hose.
- 7). Mount the valve stem caps and the service port  
Use torque wrench to tighten the service port cap to a torque of 18N.m.  
Be sure to check for gas leakage.

## 8.6 Re-installation while the indoor unit need to be repaired

### 1. Collecting the refrigerant into the outdoor unit

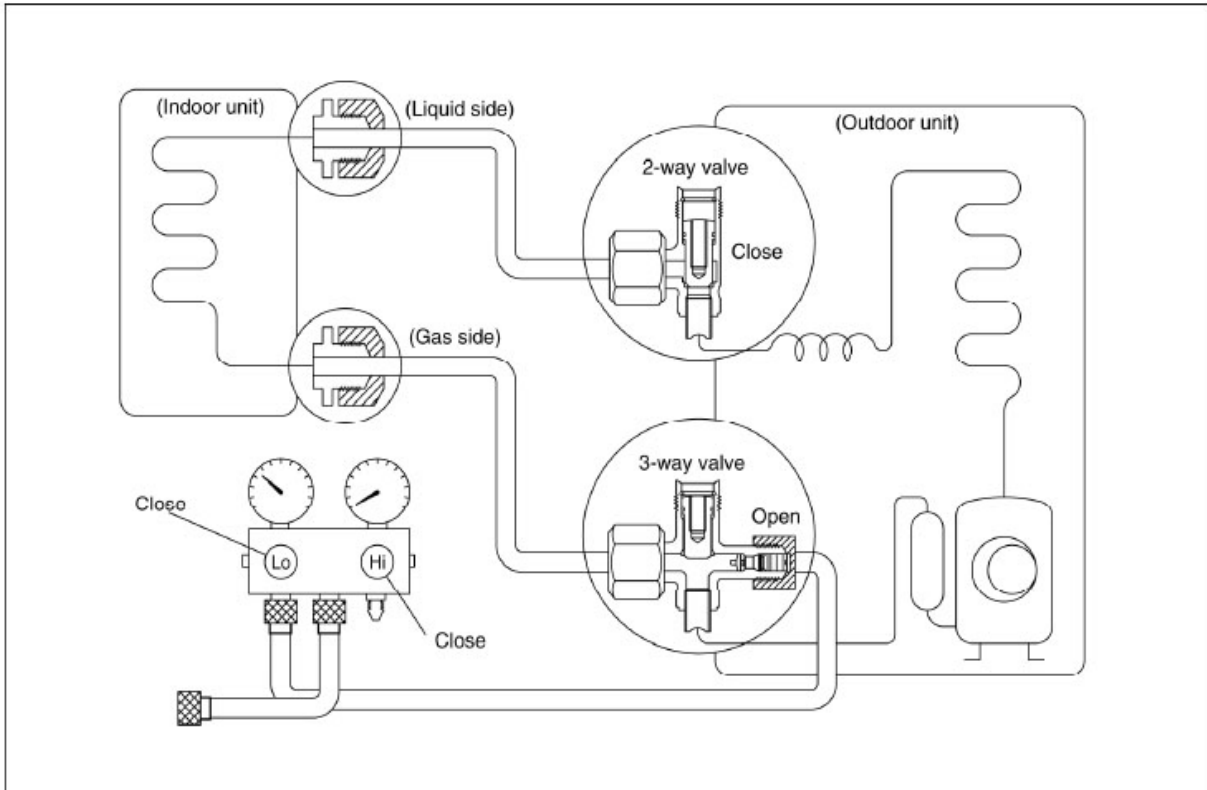

#### Procedure

- 1). Confirm that both the 2-way and 3-way valves are set to the opened position  
Remove the valve stem caps and confirm that the valve stems are in the opened position.  
Be sure to use a hexagonal wrench to operate the valve stems.
- 2). Connect the charge hose with the push pin of handle lo to the 3-way valves gas service port.
- 3). Air purging of the charge hose.  
Open the handle Lo valve of the manifold valve slightly to purge air from the charge hose for 5 seconds and then close it quickly.
- 4). Set the 2-way valve to the close position.
- 5). Operate the air conditioner at the cooling cycle and stop it when the gauge indicates 0.1MPa.
- 6). Set the 3-way valve to the closed position immediately  
Do this quickly so that the gauge ends up indicating 0.3 to 0.5Mpa.  
Disconnect the charge set, and tighten the 2-way and 3-way valve's stem nuts.  
Use a torque wrench to tighten the 3-way valves service port cap to a torque of 1.8 kgf.m.  
Be sure to check for gas leakage.

## 2. Air purging by the refrigerant

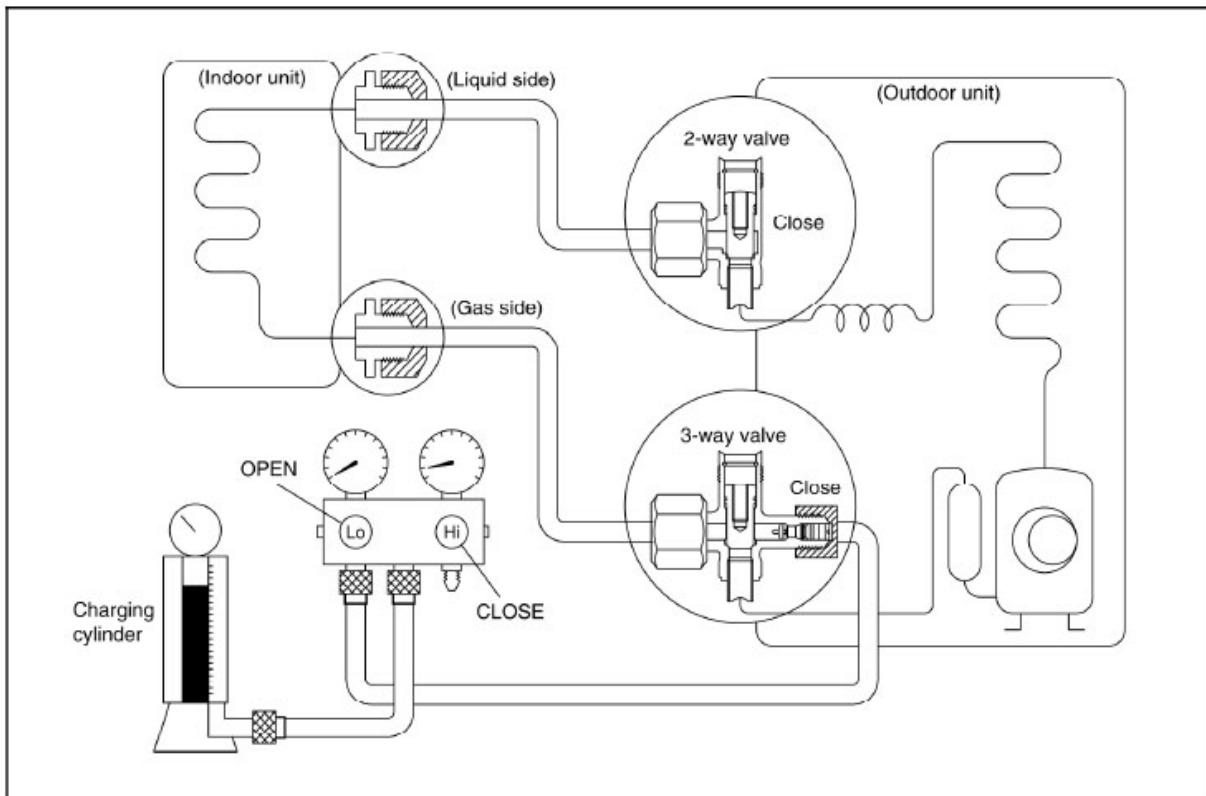

### Procedure:

- 1). Confirm that both the 2-way and 3-way valves are set to the closed position.
- 2). Connect the charge set and a charging cylinder to the service port of the 3-way valve  
Leave the valve on the charging cylinder closed.
- 3). Air purging.  
Open the valves on the charging cylinder and the charge set. Purge the air by loosening the flare nut on the 2-way valve approximately 45° for 3 seconds then closing it for 1 minute; repeat 3 times.  
After purging the air, use a torque wrench to tighten the flare nut on the 2-way valve.
- 4). Check the gas leakage  
Check the flare connections for gas leakage.
- 5). Discharge the refrigerant.  
Close the valve on the charging cylinder and discharge the refrigerant by loosening the flare nut on the 2-way valve approximately 45° until the gauge indicates 0.3 to 0.5 Mpa.
- 6). Disconnect the charge set and the charging cylinder, and set the 2-way and 3-way valves to the open position  
Be sure to use a hexagonal wrench to operate the valve stems.
- 7). Mount the valve stems nuts and the service port cap  
Be sure to use a torque wrench to tighten the service port cap to a torque 18N.m.  
Be sure to check the gas leakage.

## 8.7 Re-installation while the outdoor unit need to be repaired

### 1. Evacuation for the whole system

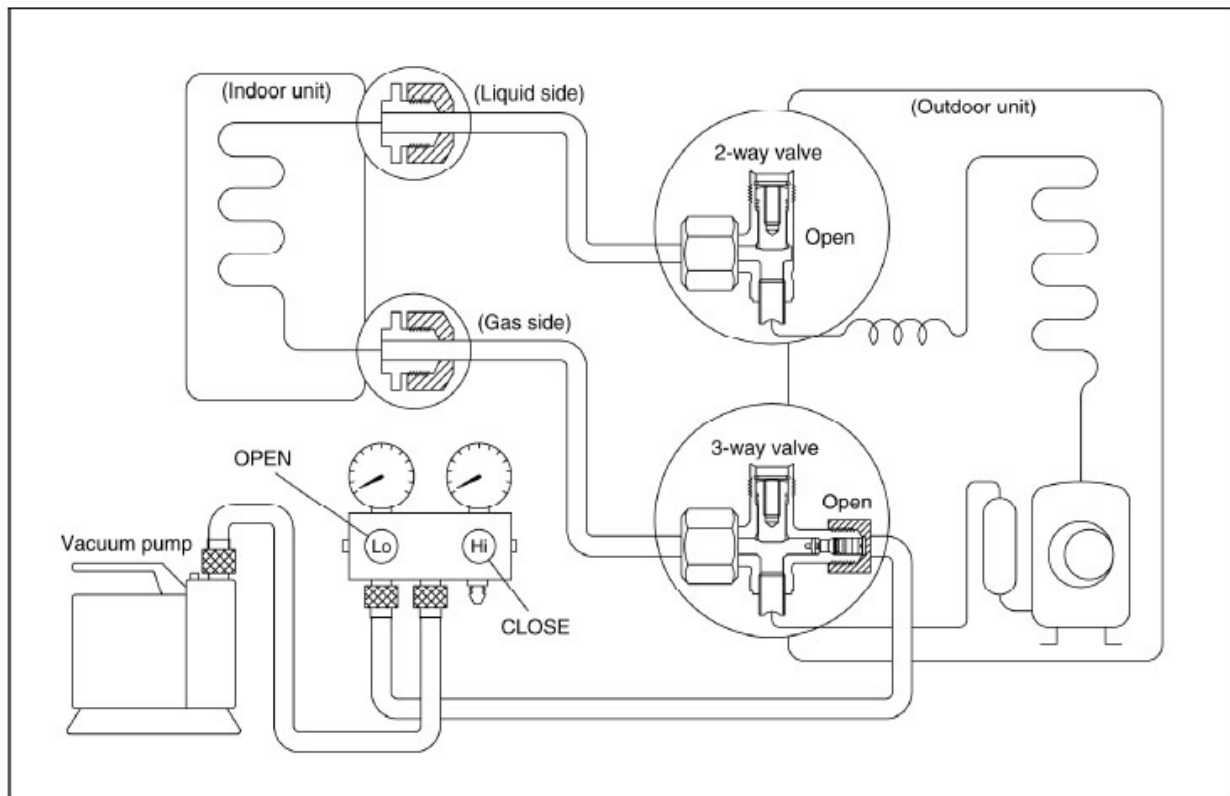

#### Procedure:

- 1). Confirm that both the 2-way and 3-way valves are set to the opened position.
- 2). Connect the vacuum pump to 3-way valve's service port.
- 3). Evacuation for approximately one hour. Confirm that the compound meter indicates  $-0.1\text{Mpa}$ .
- 4). Close the valve (Low side) on the charge set, turn off the vacuum pump, and confirm that the gauge needle does not move (approximately 5 minutes after turning off the vacuum pump).
- 5). Disconnect the charge hose from the vacuum pump.



## 2. Refrigerant charging

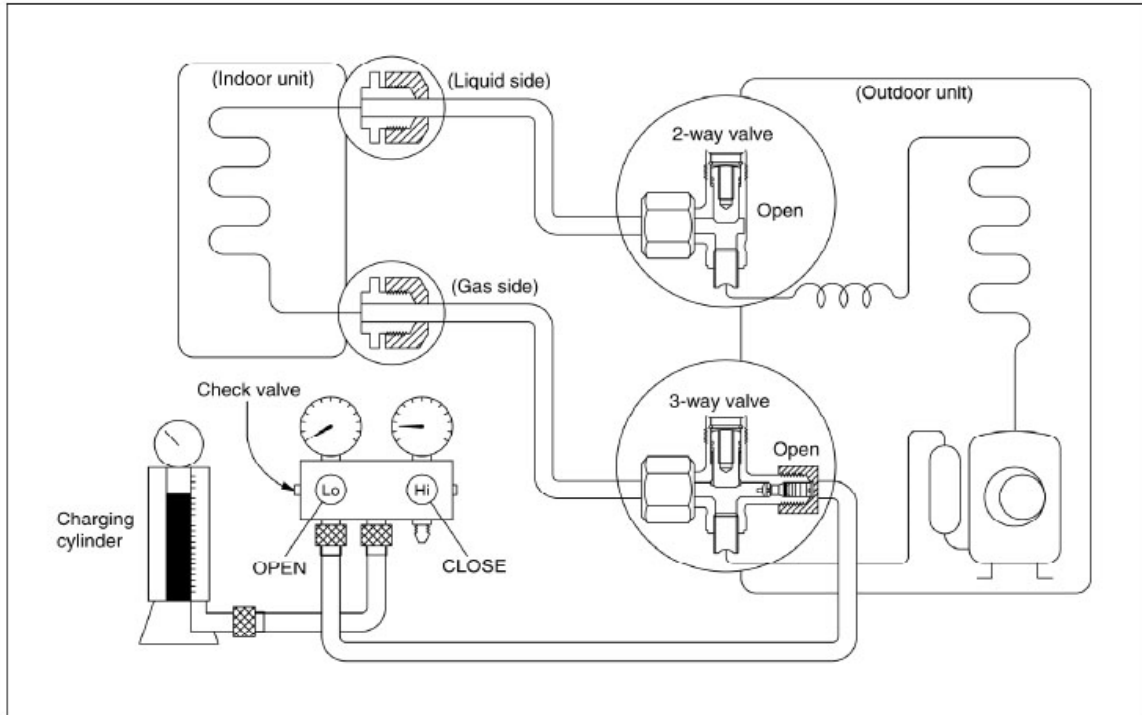

### Procedure:

- 1). Connect the charge hose to the charging cylinder, open the 2-way valve and the 3-way valve  
Connect the charge hose which you disconnected from the vacuum pump to the valve at the bottom of the cylinder. If the refrigerant is R410A, make the cylinder bottom up to ensure liquid charge.
- 2). Purge the air from the charge hose  
Open the valve at the bottom of the cylinder and press the check valve on the charge set to purge the air (be careful of the liquid refrigerant).
- 3) Put the charging cylinder onto the electronic scale and record the weight.
- 4). Open the valves (Low side) on the charge set and charge the system with liquid refrigerant  
If the system cannot be charge with the specified amount of refrigerant, or can be charged with a little at a time (approximately 150g each time) , operating the air conditioner in the cooling cycle; however, one time is not sufficient, wait approximately 1 minute and then repeat the procedure.
- 5).When the electronic scale displays the proper weight, disconnect the charge hose from the 3-way valve's service port immediately  
If the system has been charged with liquid refrigerant while operating the air conditioner, turn off the air conditioner before disconnecting the hose.
- 6). Mounted the valve stem caps and the service port  
Use torque wrench to tighten the service port cap to a torque of 18N.m.  
Be sure to check for gas leakage

## **9. Electronic control function**

### **9.1 Abbreviation**

T1: Indoor ambient temperature

T2: Coil temperature of indoor heat exchanger middle.

T2B: Coil temperature of indoor heat exchanger outlet(This sensor is located in outdoor unit)

T3: Coil temperature of outdoor heat exchanger

T4: Outdoor ambient temperature

T5: Compressor discharge temperature

Ts: Setting temperature

### **9.2 Electric control working environment.**

9.2.1 Input voltage: 198V~264V.

9.2.2 Input power frequency:50Hz.

9.2.3 Indoor fan normal working amp. is less than 1A.

9.2.4 Outdoor fan. normal working amp. is less than 1.5A.

9.2.5 Four-way valve normal working amp. is less than 1A.

### **9.3 Outdoor unit's digital display tube**

There is a digital display tube in outdoor PCB.

Digital display tube display function

- In standby , the LED displays "- -"
- In compressor operation, the LED display the running frequency,
- In defrosting mode, The LED displays "dF" or alternative displays between running frequency and "dF"(each displays 0.5s)
- In compressor pre-heating, The LED displays "PH" or alternative displays between running frequency and "PH"(each displays 0.5s)
- During the oil return process, The LED displays "RO" or alternative displays between running frequency and "RO"(each displays 0.5s)
- In low ambient cooling mode, the LED displays "LC" or alternative displays between running frequency and "LC"(each displays 0.5s)
- In forced cooling mode, the LED displays "FC" or alternative displays between running frequency and "FC"(each displays 0.5s)
- When PFC module protection occurs three times within 15 minutes, the LED displays "E6" or alternative displays between running frequency and "E6"(each displays 0.5s)
- In protection or malfunction, the LED displays error code or protection code.

## 9.4 Outdoor unit point check function

There is a check switch in outdoor PCB.

Press the switch N times it will display the content corresponding to No. N. After getting into the check function, it will display No. N with 1.5s, meanwhile the low bit decimal of digit display flashing, indicated to get into the check function display. After 1.5s, it will display the content corresponding to No. N.

the digital display tube will display the follow procedure when push SW1 each time.

	Display	Remark
0	Normal display	Display running frequency, running state or malfunction code
1	No. of indoor units in good connection	Actual data
2	Outdoor unit running mode code	Standby:0,Fan only 1, Cooling:2, Heating:3, Forced cooling:4 Forced defrosting:5
3	A indoor unit capacity	The capacity unit is horse power. If the indoor unit is not connected, the digital display tube will show: "____" (7K:0.8HP, 9K:1HP,12K:1.2HP,18K:1.5HP)
4	B indoor unit capacity	
5	C indoor unit capacity	
6	D indoor unit capacity	
7	E indoor unit capacity	
8	A Indoor unit capacity demand code	Norm value*HP (7K:0.8HP, 9K:1HP,12K:1.2HP,18K:1.5HP)
9	B Indoor unit capacity demand code	
10	C Indoor unit capacity demand code	
11	D Indoor unit capacity demand code	
12	E Indoor unit capacity demand code	
13	Total indoor units amendatory capacity demand code	
14	The frequency corresponding to the total indoor units amendatory capacity demand	
15	The frequency after the frequency limit	
16	The frequency sending to compressor control chip	
17	A indoor unit evaporator outlet temperature(T <sub>2B</sub> A)	If the temperature is lower than -9 degree, the digital display tube will show "-9".If the temperature is higher than 70 degree, the digital display tube will show "70". If the indoor unit is not connected, the digital display tube will show: "____"
18	B indoor unit evaporator outlet temperature(T <sub>2B</sub> B)	
19	C indoor unit evaporator outlet temperature(T <sub>2B</sub> C)	
20	D indoor unit evaporator outlet temperature(T <sub>2B</sub> D)	
21	E indoor unit evaporator outlet temperature(T <sub>2B</sub> E)	
22	A indoor unit room temperature(T <sub>1</sub> A)	If the temperature is lower than 0 degree, the digital display tube will show "0".If the temperature is higher than 70 degree, the digital display tube will show "70". If the indoor unit is not connected, the digital display tube will show: "____"
23	B indoor unit room temperature(T <sub>1</sub> B)	
24	C indoor unit room temperature(T <sub>1</sub> C)	
25	D indoor unit room temperature(T <sub>1</sub> D)	
26	E indoor unit room temperature(T <sub>1</sub> E)	
27	A indoor unit evaporator temperature(T <sub>2</sub> A)	If the temperature is lower than -9 degree, the digital display tube will show "-9".If the temperature is higher than 70 degree, the digital display tube will show "70". If the indoor unit is not connected, the digital display tube will show: "____"
28	B indoor unit evaporator temperature(T <sub>2</sub> B)	
29	C indoor unit evaporator temperature(T <sub>2</sub> C)	
30	D indoor unit evaporator temperature(T <sub>2</sub> D)	
31	E indoor unit evaporator temperature(T <sub>2</sub> E)	
32	Condenser pipe temperature(T <sub>3</sub> )	
33	Outdoor ambient temperature(T <sub>4</sub> )	
34	Compressor discharge temperature(T <sub>5</sub> )	The display value is between 30~129 degree. If the temperature is lower than 30 degree, the digital display tube will show "30".If the temperature is higher than 99 degree, the digital display tube will show single digit and tens digit. For example, the digital display tube

		show "0.5",it means the compressor discharge temperature is 105 degree.)		
35	AD value of current	The display value is hex number.		
36	AD value of voltage	For example ,the digital display tube show "Cd", it means AD value is 205.		
37	EXV open angle for A indoor unit	Actual data/4. If the value is higher than 99, the digital display tube will show single digit and tens digit. For example ,the digital display tube show "2.0",it means the EXV open angle is 120×4=480p.)		
38	EXV open angle for B indoor unit			
39	EXV open angle for C indoor unit			
40	EXV open angle for D indoor unit			
41	EXV open angle for E indoor unit			
42	Frequency limit symbol	Bit7	Frequency limit caused by IGBT radiator	The display value is hex number. For example, the digital display tube show 2A,then Bit5=1, Bit3=1, Bit1=1. It means frequency limit caused by T4,T3 and current.
		Bit6	Frequency limit caused by PFC	
		Bit5	Frequency limit caused by T4.	
		Bit4	Frequency limit caused by T2.	
		Bit3	Frequency limit caused by T3.	
		Bit2	Frequency limit caused by T5.	
		Bit1	Frequency limit caused by current	
		Bit0	Frequency limit caused by voltage	
43	Average value of T2	(Sum T2 value of all indoor units)/( number of indoor units in good connection)(cooling:T2B, heating:T2)		
44	Outdoor unit fan motor state	Fan off:0, High speed:1, Med speed:2, Low speed:3 Breeze:4, Super breeze:5		
45	The last error or protection code	00 means no malfunction and protection		

## 9.5 Protection

### 9.5.1 Three minutes delay at restart for compressor.

### 9.5.2 Temperature protection of compressor discharge.

When the compressor discharge temperature is getting higher, the running frequency will be limited as below rules:

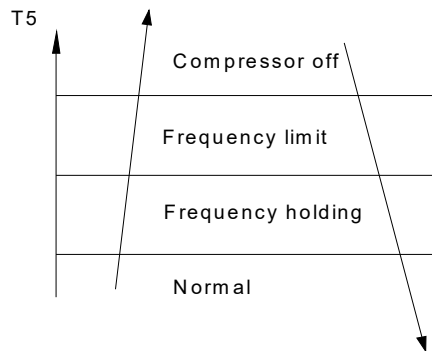

### 9.5.3 Low voltage protection

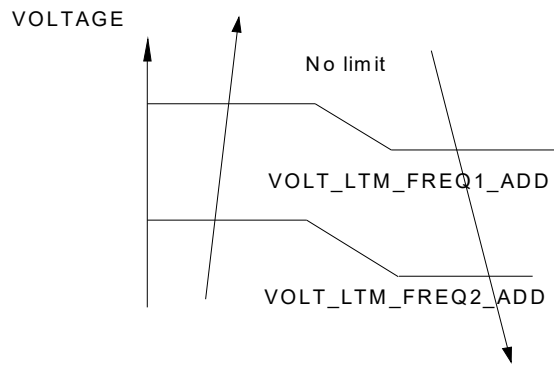

Note: if the low voltage protection occurs and not resumes within 3min, it will keep the protection always after restart the machine.

### 9.5.4 Compressor current limit protection

Temperature interval of current limit is same as range of T4 limited frequency.

**Cooling mode:**

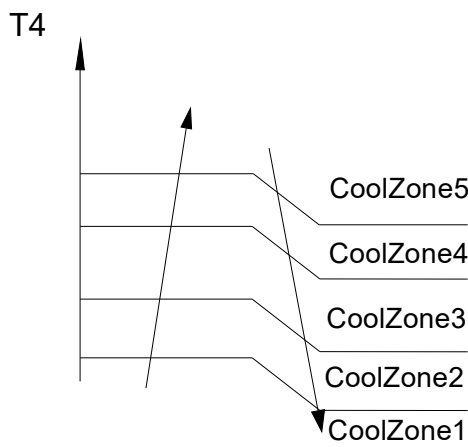

**Heating mode:**

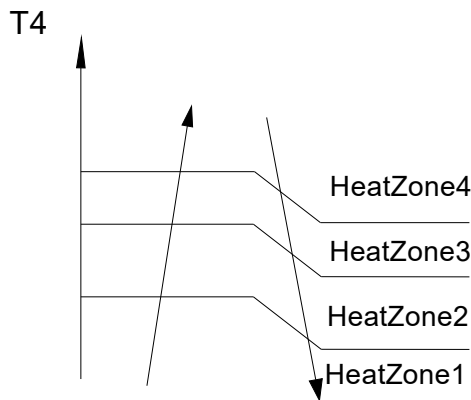

### 9.5.5 Indoor / outdoor units communication protection

If the indoor units cannot receive the feedback signal from the outdoor units for 2 minutes, the AC will stop and display the failure.

### 9.5.6 High condenser coil temperature protection.

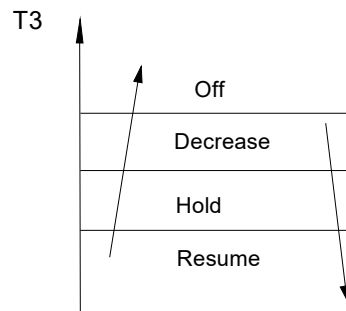

### 9.5.7 Outdoor unit anti-freezing protection

When  $T2 < 4^{\circ}\text{C}$  for 250 seconds or  $T2 < 0^{\circ}\text{C}$ , the indoor unit capacity demand will be zero and resume to normal when  $T2 > 8^{\circ}\text{C}$  and the time of protection is no less than 3 minutes.

### 9.5.8 Oil return

#### Running rules:

1. If the compressor frequency keeps lower than setting frequency for setting time, the AC will rise the frequency to setting frequency for setting time and then resume to former frequency.
2. The EXV will keep 300p while the indoor units will keep the current running mode.

If the outdoor ambient is higher than setting frequency during the oil return, the AC quit oil return.

### 9.5.9 Low outdoor ambient temperature protection

When compressor is off,  $T4$  is be lower than  $-35^{\circ}\text{C}$ .for 10s, the AC will stop and display "LP".

When compressor is on,  $T4$  is be lower than  $-40^{\circ}\text{C}$ .for 10s, the AC will stop and display "LP".

When  $T4$  is no lower than  $-32^{\circ}\text{C}$ .for 10s, the unit will exit protection.

## 10. Troubleshooting

### 10.1 Indoor unit error code explanation:

Malfunction	Error Code	Timer Lamp	Operation Lamp (flashes)
Indoor EEPROM malfunction	E0	X	1
Communication malfunction between indoor and outdoor units	E1	X	2
Indoor fan speed has been out of control	E3	X	4
Open or short circuit of T1 temperature sensor	E4	X	5
Open or short circuit of T2 temperature sensor	E5	X	6
Water level alarm	EE	X	8
Overcurrent protection (For some units)	F0	O	1
Open or short circuit of T4 temperature sensor	F1	O	2
Open or short circuit of T3 temperature sensor	F2	O	3
Open or short circuit of T5 temperature sensor	F3	O	4
Outdoor EEPROM malfunction (For some units)	F4	O	5
Outdoor fan speed is out of control	F5	O	6
Open or short circuit of T2B temperature sensor (For free-match indoor units)	F6	O	7
Communication error between auto-lifting panel and slim cassette (For slim cassette with auto-lifting panel)	F7	O	8
Auto-lifting panel is faulty (For slim cassette with auto-lifting panel)	F8	O	9
Auto-lifting panel is not closed (For slim cassette with auto-lifting panel)	F9	O	10
IPM module malfunction	P0	☆	1
Over voltage or over low voltage protection	P1	☆	2
Too low ambient temperature protection	P3	☆	4
Error rotor position protection of compressor	P4	☆	5
Mode conflict	P5( for Premier &Oasis models) --(for other models)	☆	6
Low pressure protection of compressor	P6	☆	7
<b>O (on) X(off) ☆(flash at 2Hz)</b>			

### 10.2 Outdoor unit error code explanation:

Display	LED STATUS
E0	Outdoor EEPROM malfunction
E2	Indoor / outdoor units communication error
E3	Communication malfunction between IPM board and outdoor main board
E4	Open or short circuit of outdoor unit temperature sensor
E5	Voltage protection
E8	Outdoor fan speed has been out of control

F1	No A Indoor unit coil outlet temperature sensor or connector of sensor is defective
F2	No B Indoor unit coil outlet temperature sensor or connector of sensor is defective
F3	No C Indoor unit coil outlet temperature sensor or connector of sensor is defective
F4	No D Indoor unit coil outlet temperature sensor or connector of sensor is defective
F5	No E Indoor unit coil outlet temperature sensor or connector of sensor is defective
P1	High pressure protection (ForYU4E28YEEMHO-X, YU4E36YEEMHO-X, YU5E42YEEMHO-X)
P2	Low pressure protection (ForYU4E28YEEMHO-X, YU4E36YEEMHO-X, YU5E42YEEMHO-X)
P3	Current protection of compressor
P4	Temperature protection of compressor discharge
P5	High temperature protection of condenser
P6	IPM module protection
LP	Low ambient temperature protection

Note: Once these error codes display, they will disappear in at least 30 seconds if the unit come back to normal.(Except E2&E3)



## 10.3 Trouble shooting

### 10.3.1 For the indoor unit

#### 10.3.1.1 Indoor EEPROM parameter error

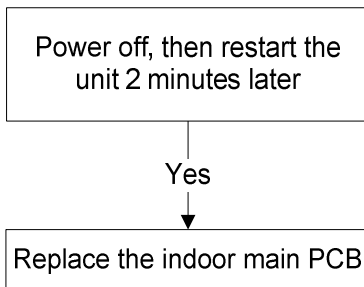

EEPROM: An electrically erasable programmable read-only memory whose contents can be erased and reprogrammed using a pulsed voltage.

### 10.3.1.2 Indoor / outdoor units communication error

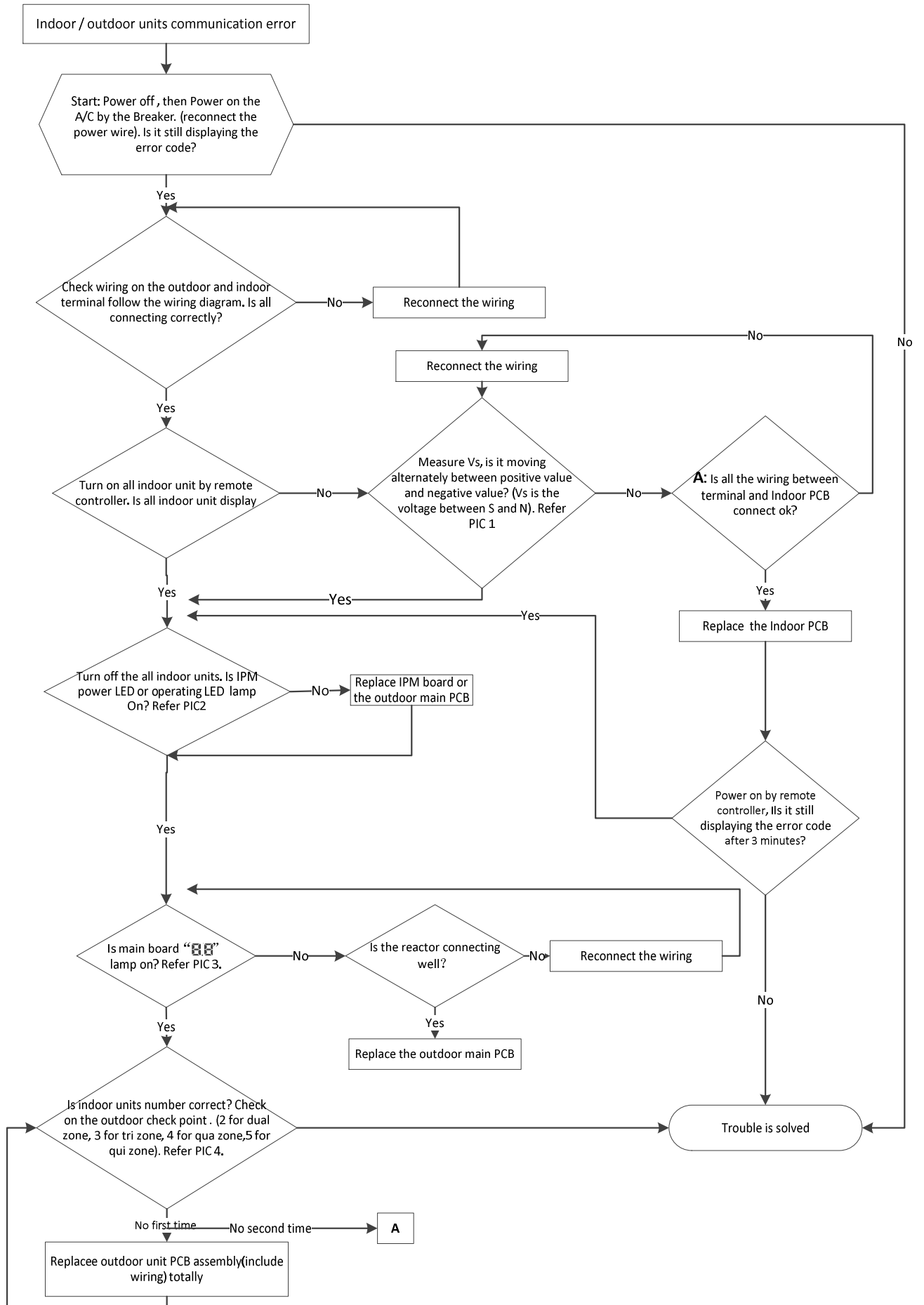



Pic 1: check the voltage of N to S (Vs), is it moving alternately between positive value and negative value?



Operating  
Self-Check

Pic 2: IPM or outdoor main PCB



Power,  
Self-Check  
Operating

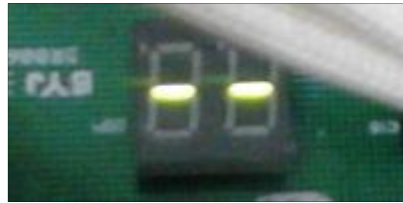

PIC3 :Main board LED when power on and unit standby.

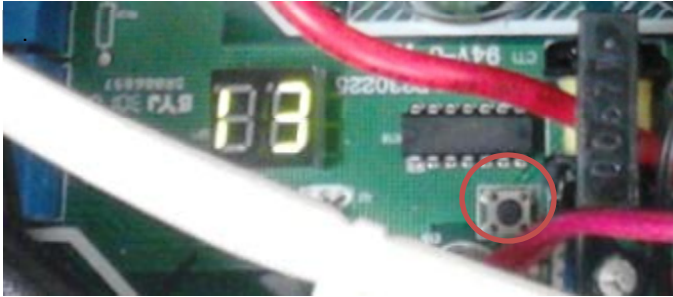

PIC 4: check point button,  
Press 1 time for check how many indoor units are connected

### 10.3.1.3 indoor unit fan speed has been out of control

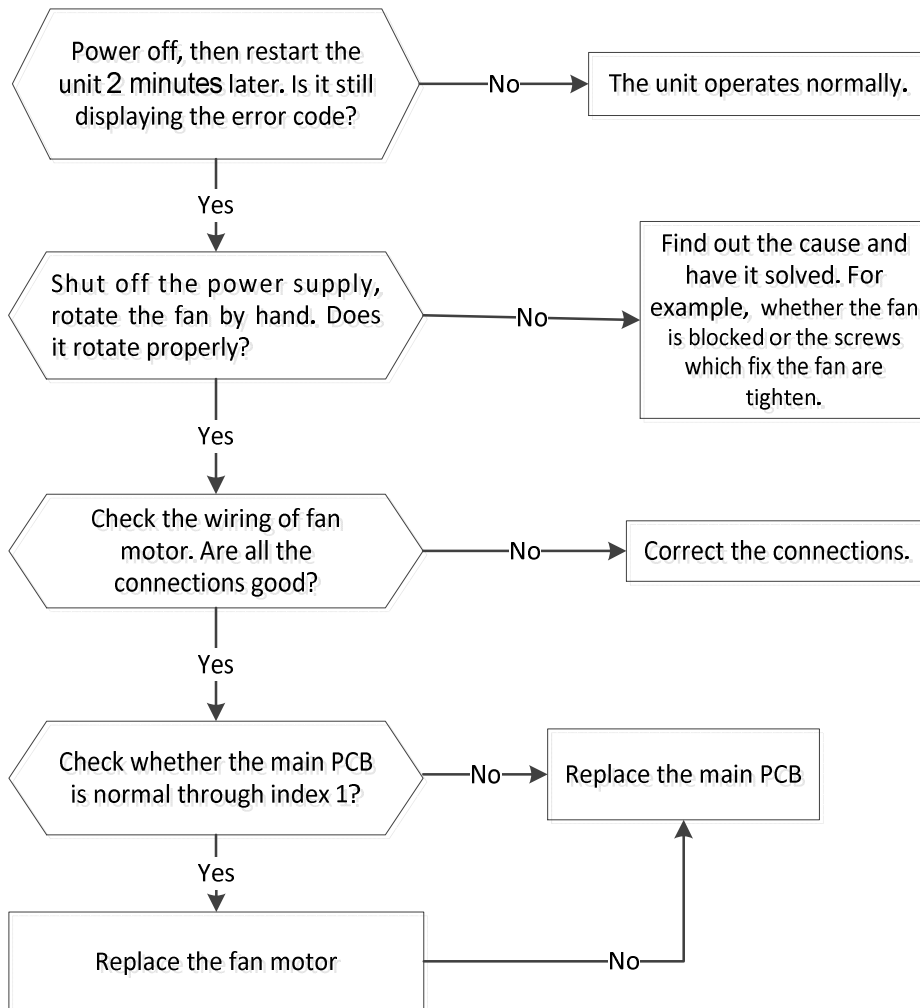

Index 1:

#### 1: Indoor AC fan motor

Power on and set the unit running in fan mode at high fan speed. After running for 15 seconds, measure the voltage of pin1 and pin2. If the value of the voltage is less than 100V(208~240V power supply) or 50V(115V power supply), the PCB must have problems and need to be replaced.

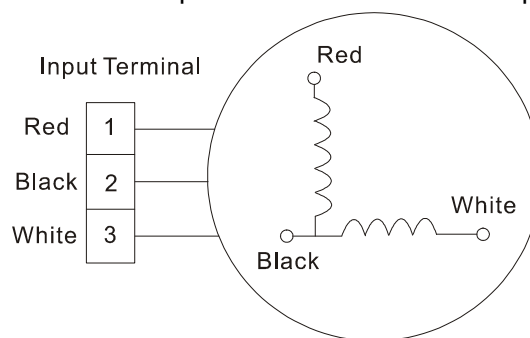

#### 2. Indoor DC fan motor(control chip is inside fan motor)

Power on and when the unit is in standby, measure the voltage of pin1-pin3, pin4-pin3 in fan motor connector. If the value of the voltage is not in the range showing in below table, the PCB must have problems and need to be replaced.

For other models:

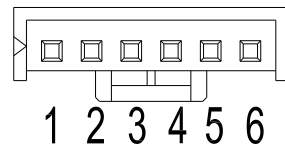
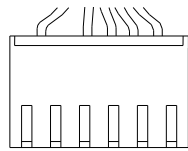

For console:

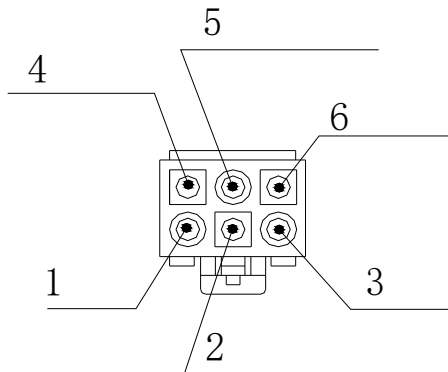

DC motor voltage input and output

For split type:

NO.	Color	Signal	Voltage
1	Red	Vs/Vm	280V~380V
2	---	---	---
3	Black	GND	0V
4	White	Vcc	14-17.5V
5	Yellow	Vsp	0~5.6V
6	Blue	FG	14-17.5V

For other types:

NO.	Color	Signal	Voltage
1	Red	Vs/Vm	192V~380V
2	---	---	---
3	Black	GND	0V
4	White	Vcc	13.5-16.5V
5	Yellow	Vsp	0~6.5V
6	Blue	FG	13.5-16.5V

### 10.3.1.4 Open or short circuit of temperature sensor.

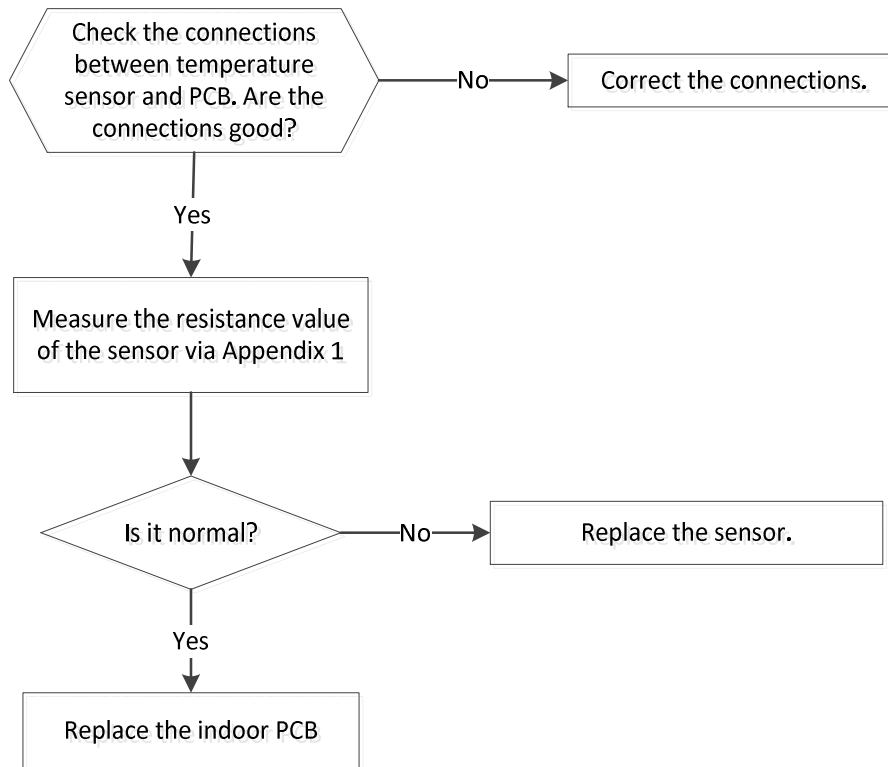

### 10.3.1.5 Full-water malfunction

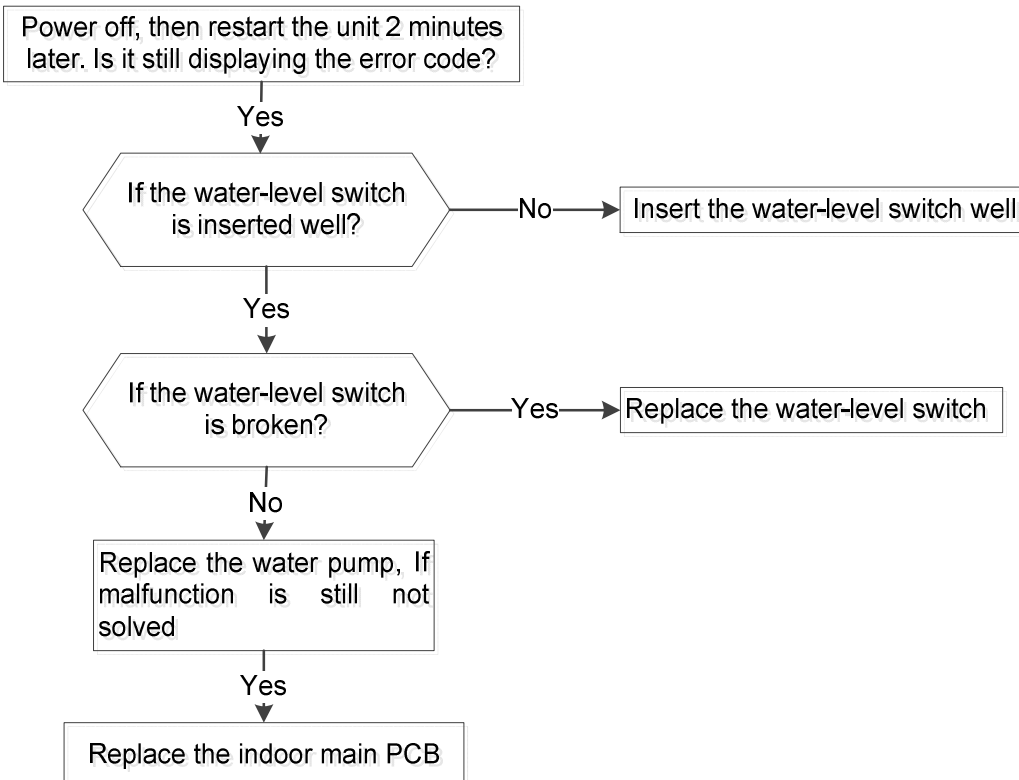

10.3.2 For the super-slim cassette with up-down panel

10.3.2.1 Communication error between indoor unit and up-down panel

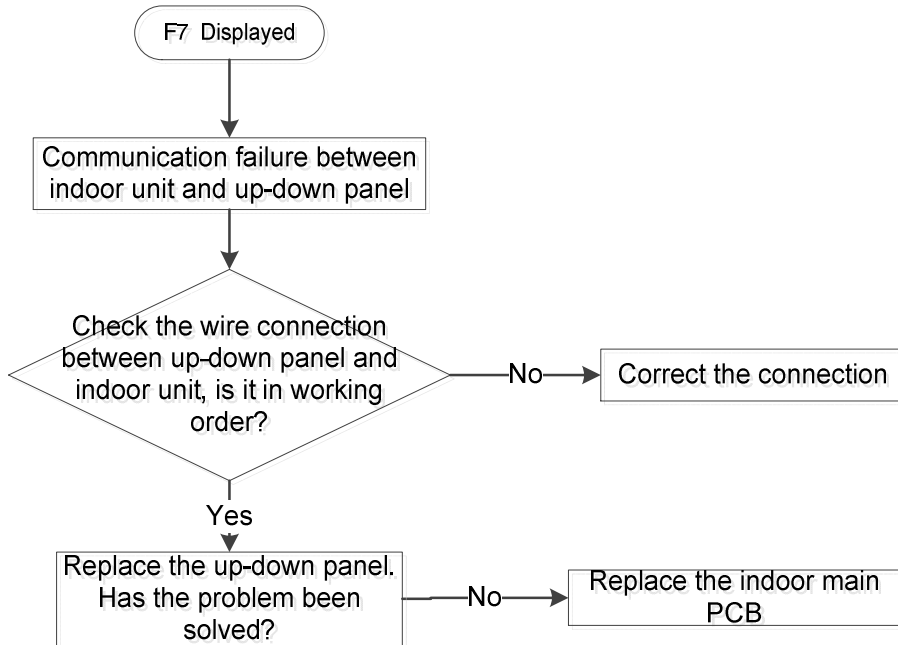

10.3.2.2 Up-down panel is defective

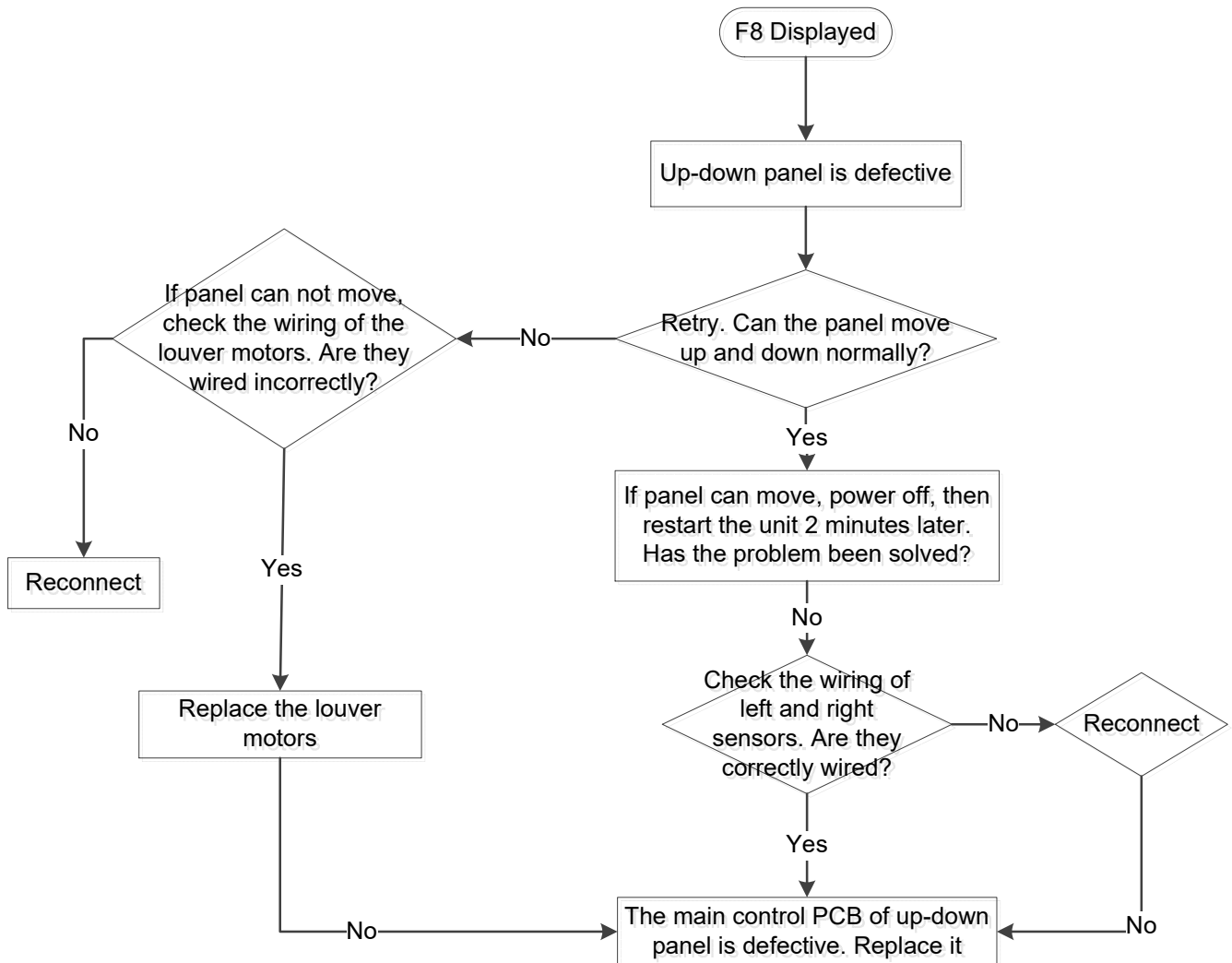



### 10.3.3 For the outdoor unit

#### 10.3.3.1 Outdoor EEPROM parameter error(ODU E0)

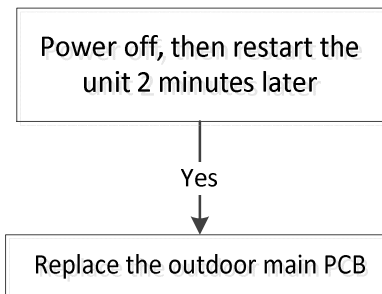

EEPROM: An electrically erasable programmable read-only memory whose contents can be erased and reprogrammed using a pulsed voltage.

### 10.3.3.2 Communication malfunction between IPM board and outdoor main board(ODU E3)

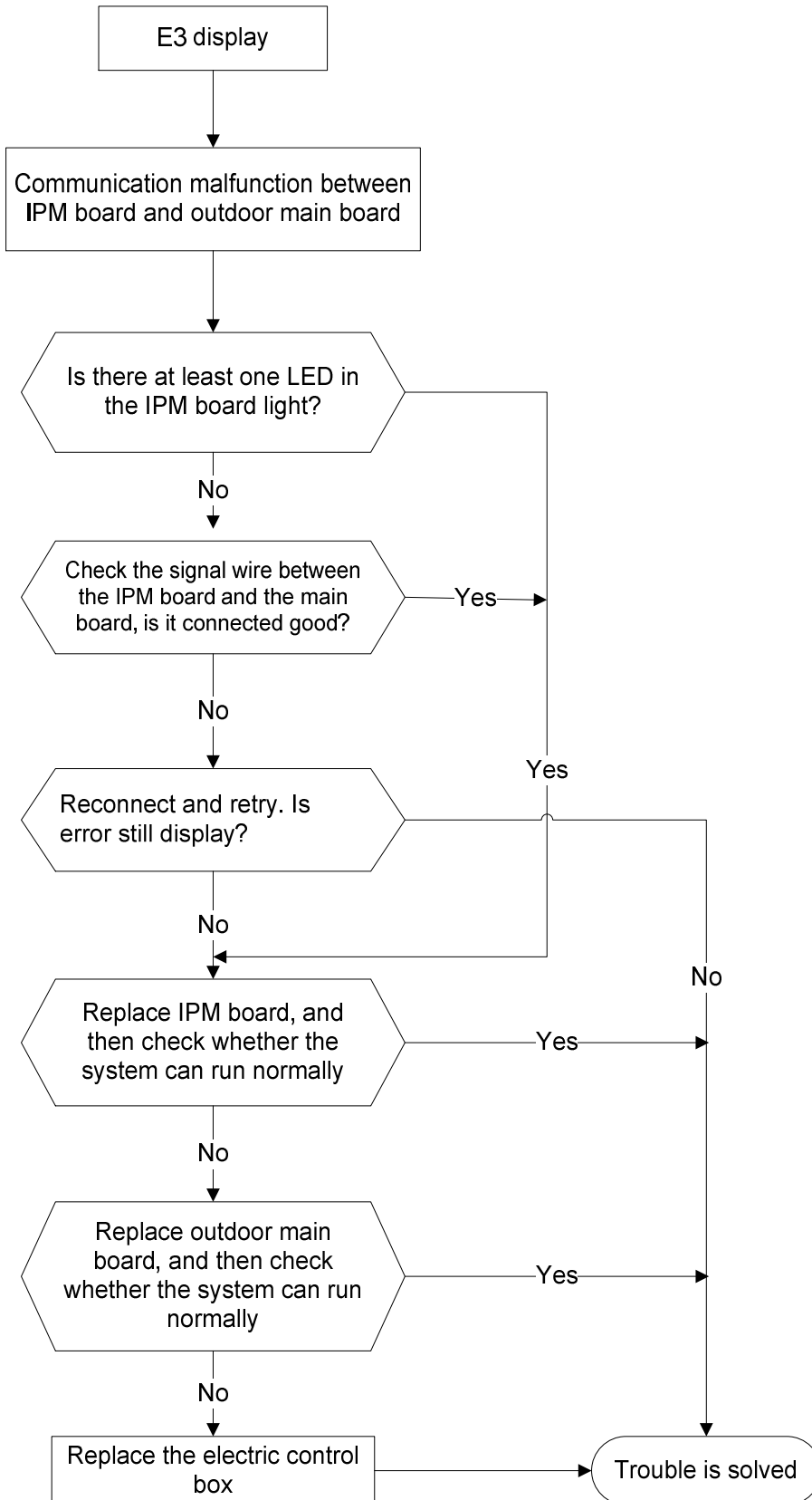

### 10.3.3.3 Voltage protection(ODU E5)

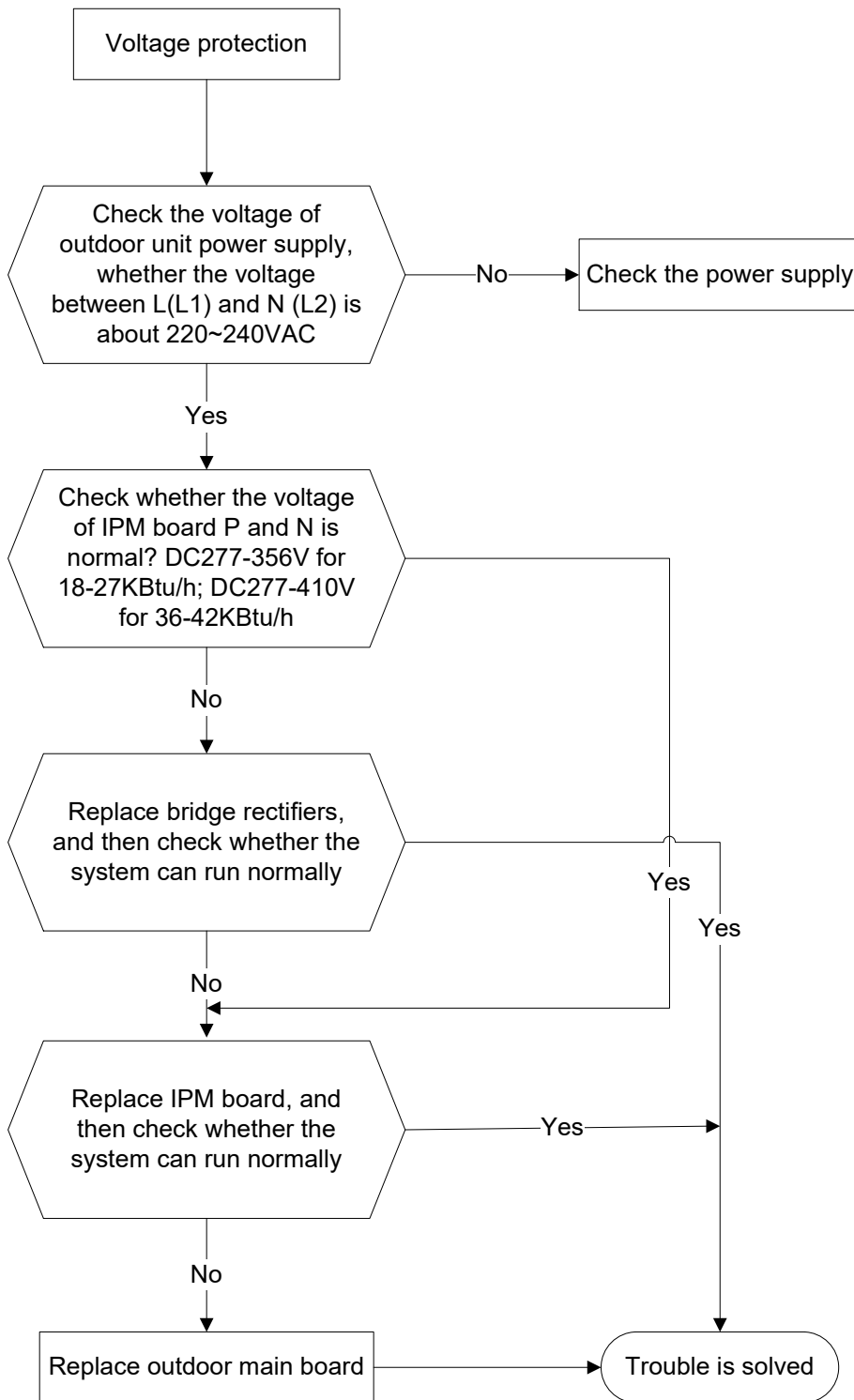

### 10.3.3.4 Outdoor unit fan speed has been out of control (E8)

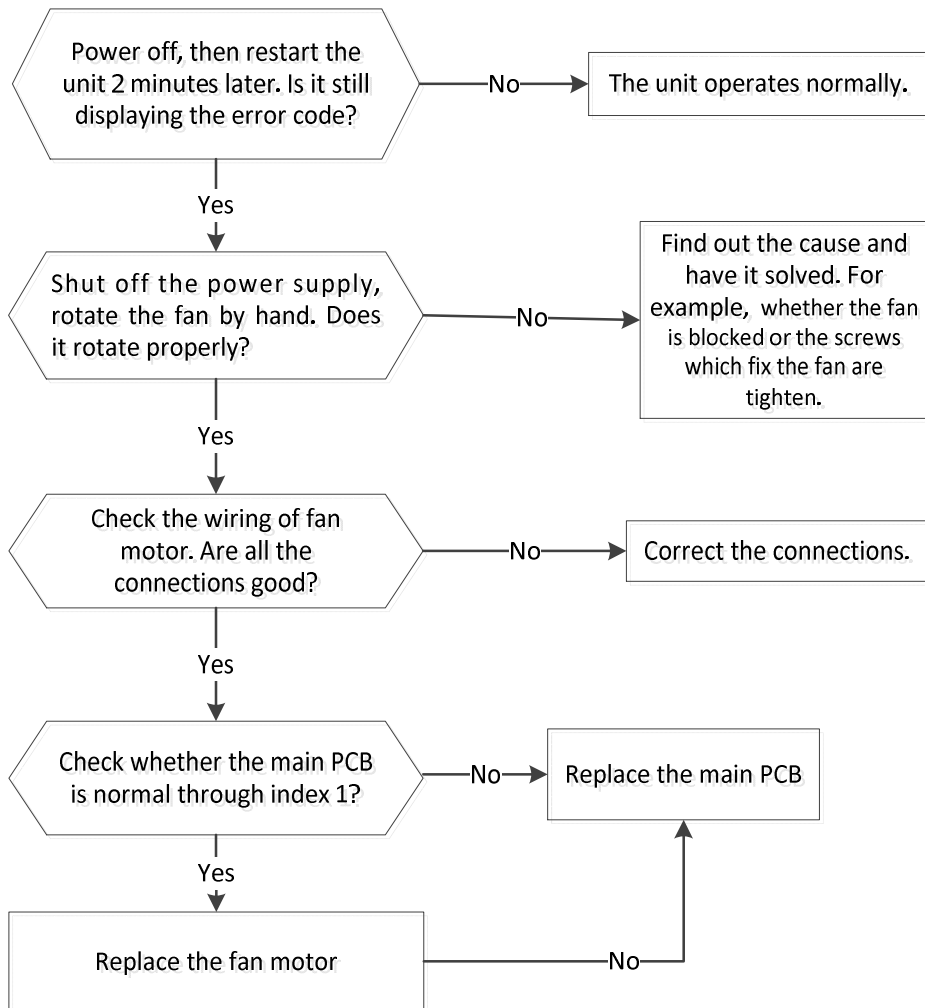

Index 1:

1. Outdoor DC fan motor(control chip is inside fan motor)

Power on and when the unit is in standby, measure the voltage of pin1-pin3, pin4-pin3 in fan motor connector. If the value of the voltage is not in the range showing in below table, the PCB must have problems and need to be replaced.

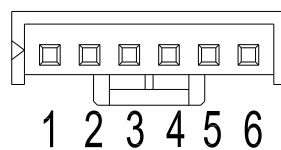

DC motor voltage input and output

NO.	Color	Signal	Voltage
1	Red	Vs/Vm	140V~380V
2	---	---	---
3	Black	GND	0V
4	White	Vcc	13.5-16.5V
5	Yellow	Vsp	0~6.5V
6	Blue	FG	15V

2. Outdoor DC Fan Motor (control chip is in outdoor PCB)

Release the UVW connector. Measure the resistance of U-V, U-W, V-W. If the resistance is not equal to each other, the fan motor must has problems and need to be replaced. otherwise the PCB must has problems and need to be replaced.

**10.3.3.5 High pressure protection (ODU P1)(ForYU4E28YEEMHO-X, YU4E36YEEMHO-X, YU5E42YEEMHO-X)**

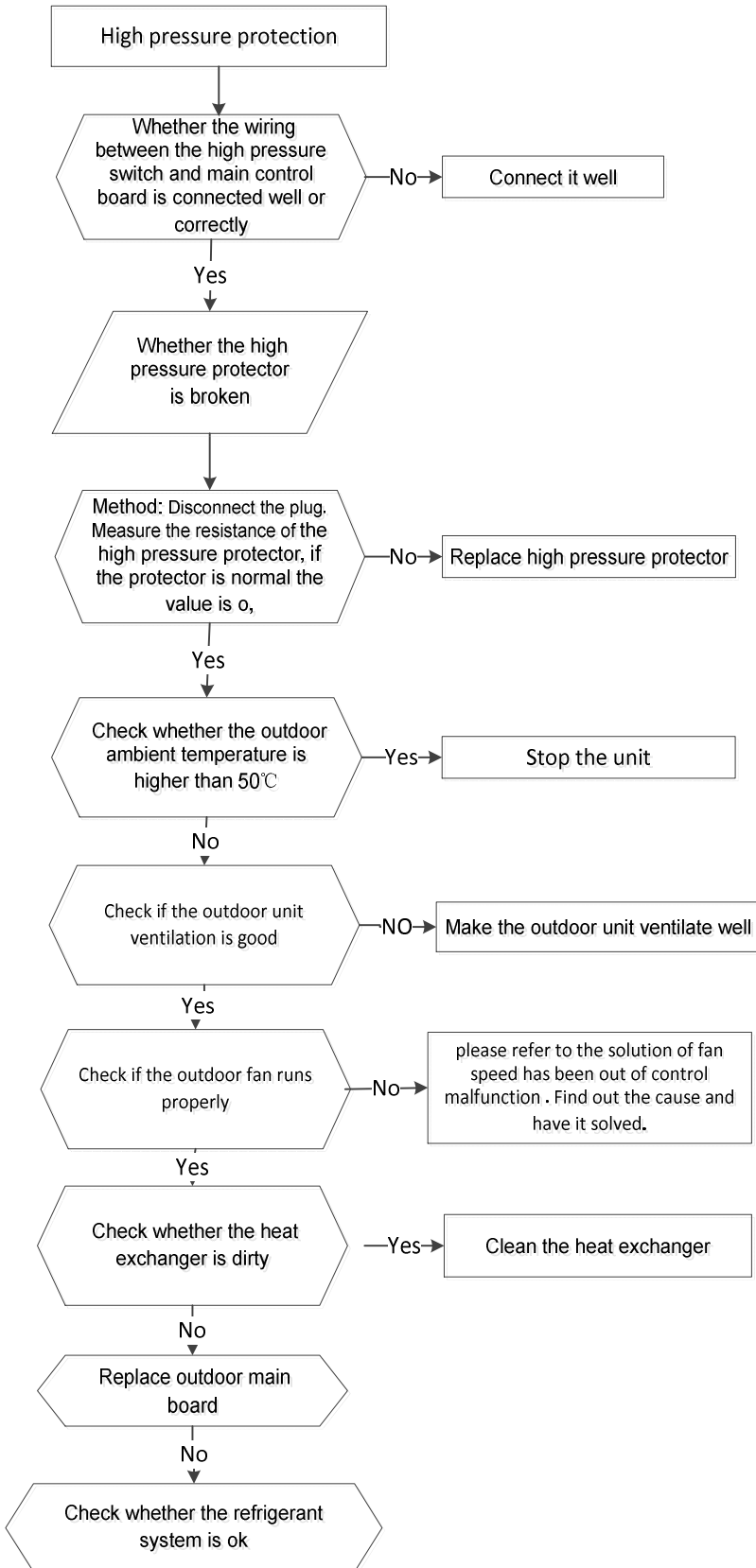

**10.3.3.6 Low pressure protection (ODU P2)(For YU4E28YEEMHO-X, YU4E36YEEMHO-X, YU5E42YEEMHO-X)**

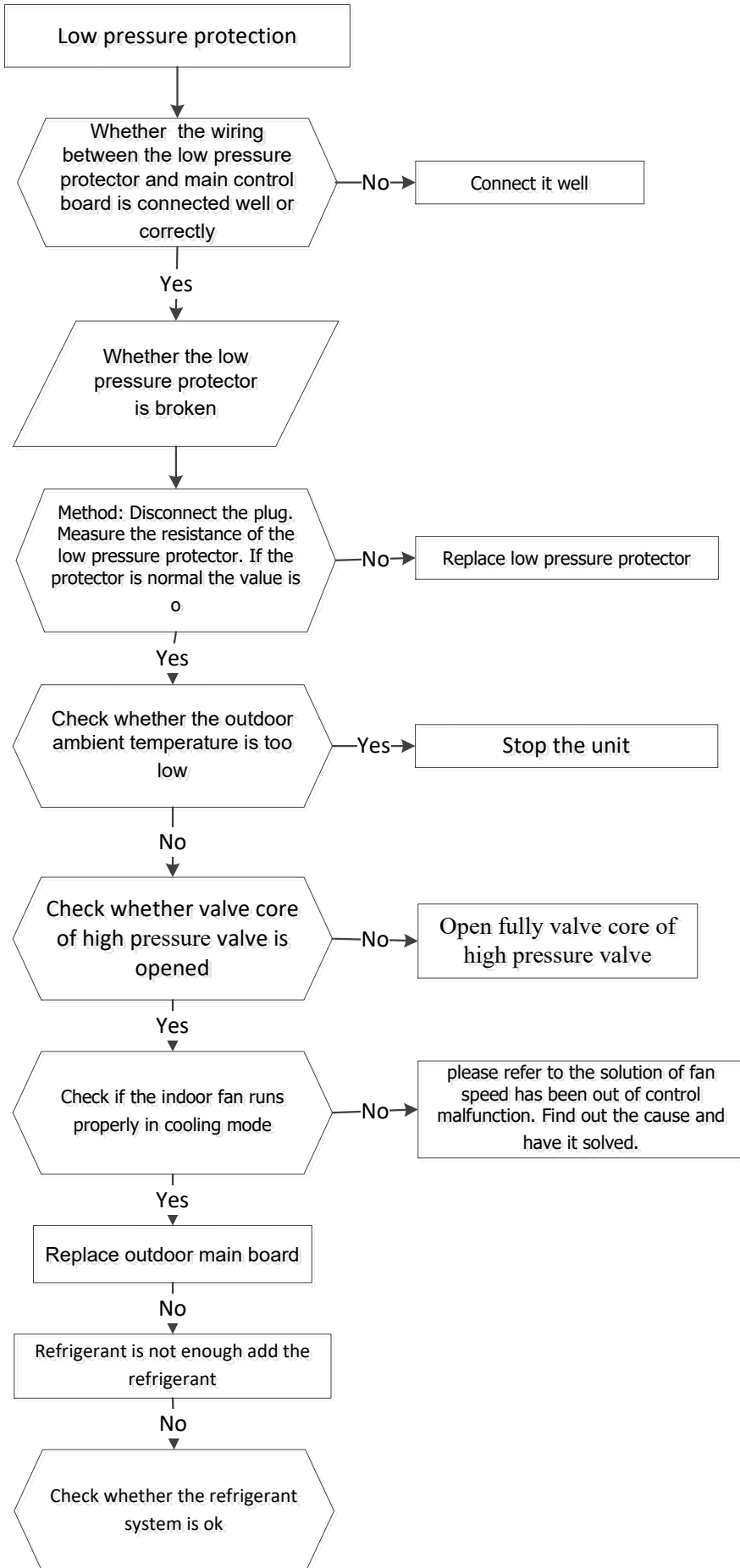

### 10.3.3.7 Current protection of compressor (ODU P3)

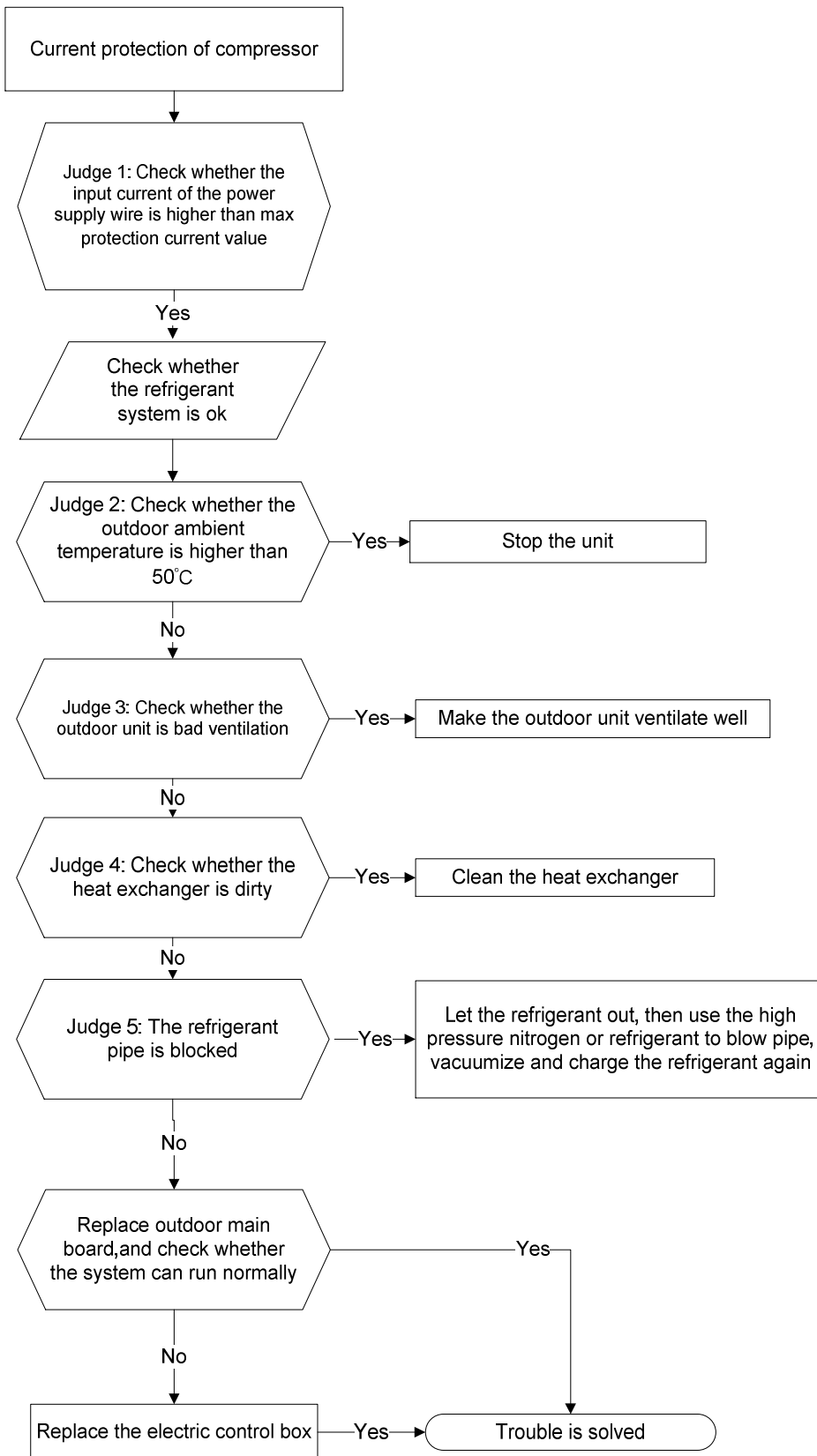

### 10.3.3.8 Temperature protection of compressor discharge (ODU P4)

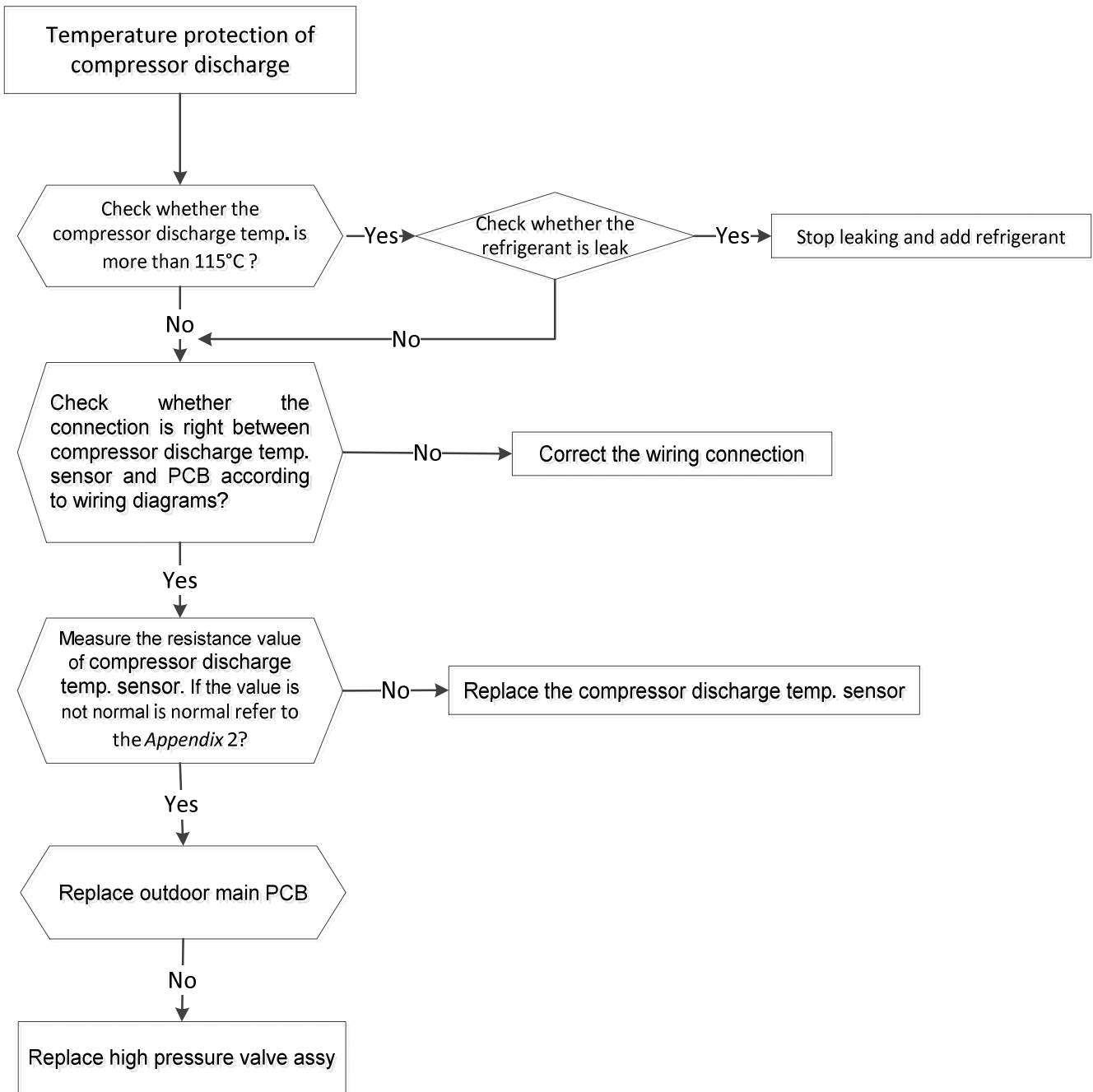



### 10.3.3.9 High temperature protection of condenser (ODU P5)

When outdoor pipe temperature is more than 65°C, the unit will stop, and unit runs again when outdoor pipe temperature less than 52°C.

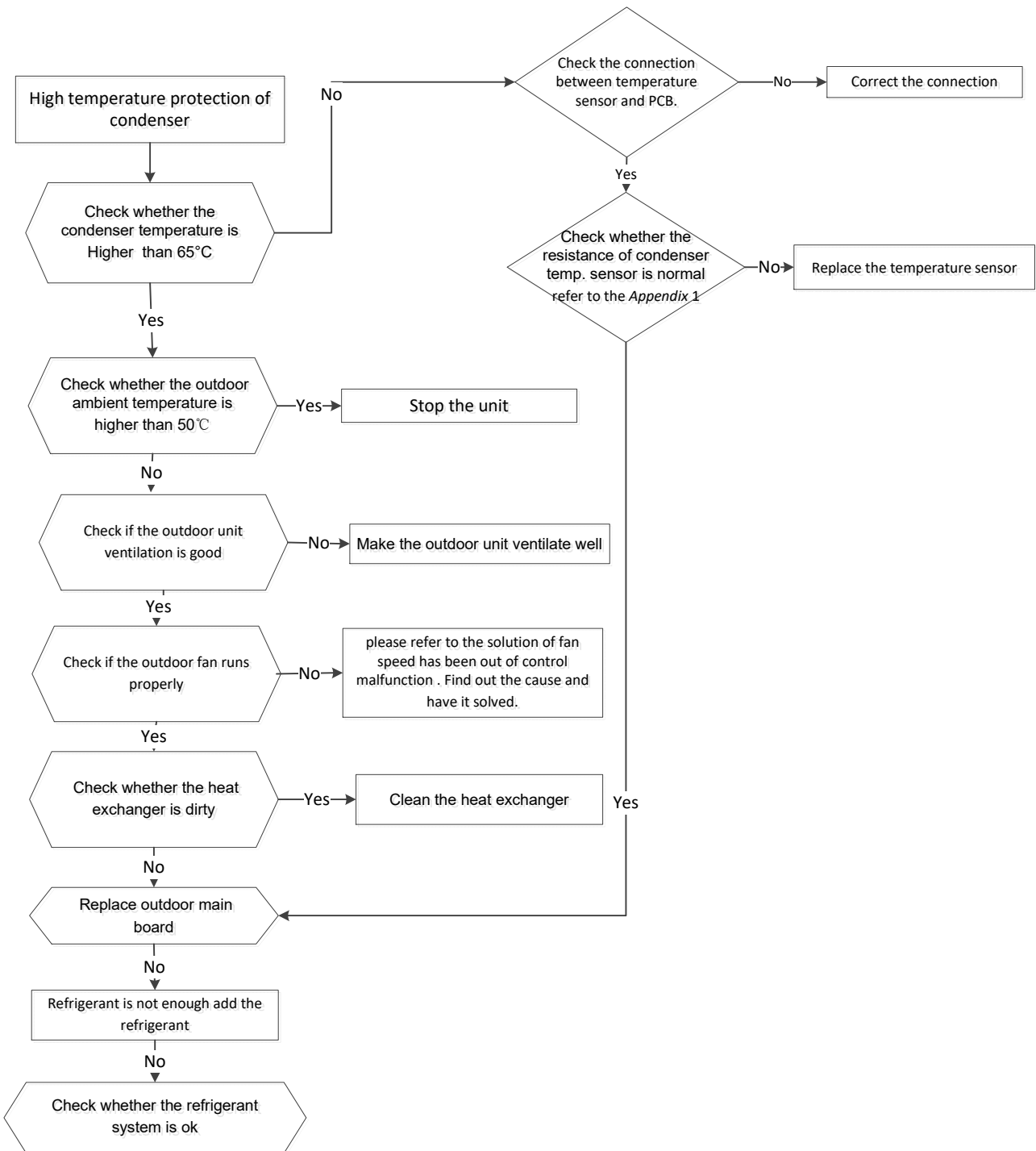

### 10.3.3.10 IPM module protection (ODU P6)

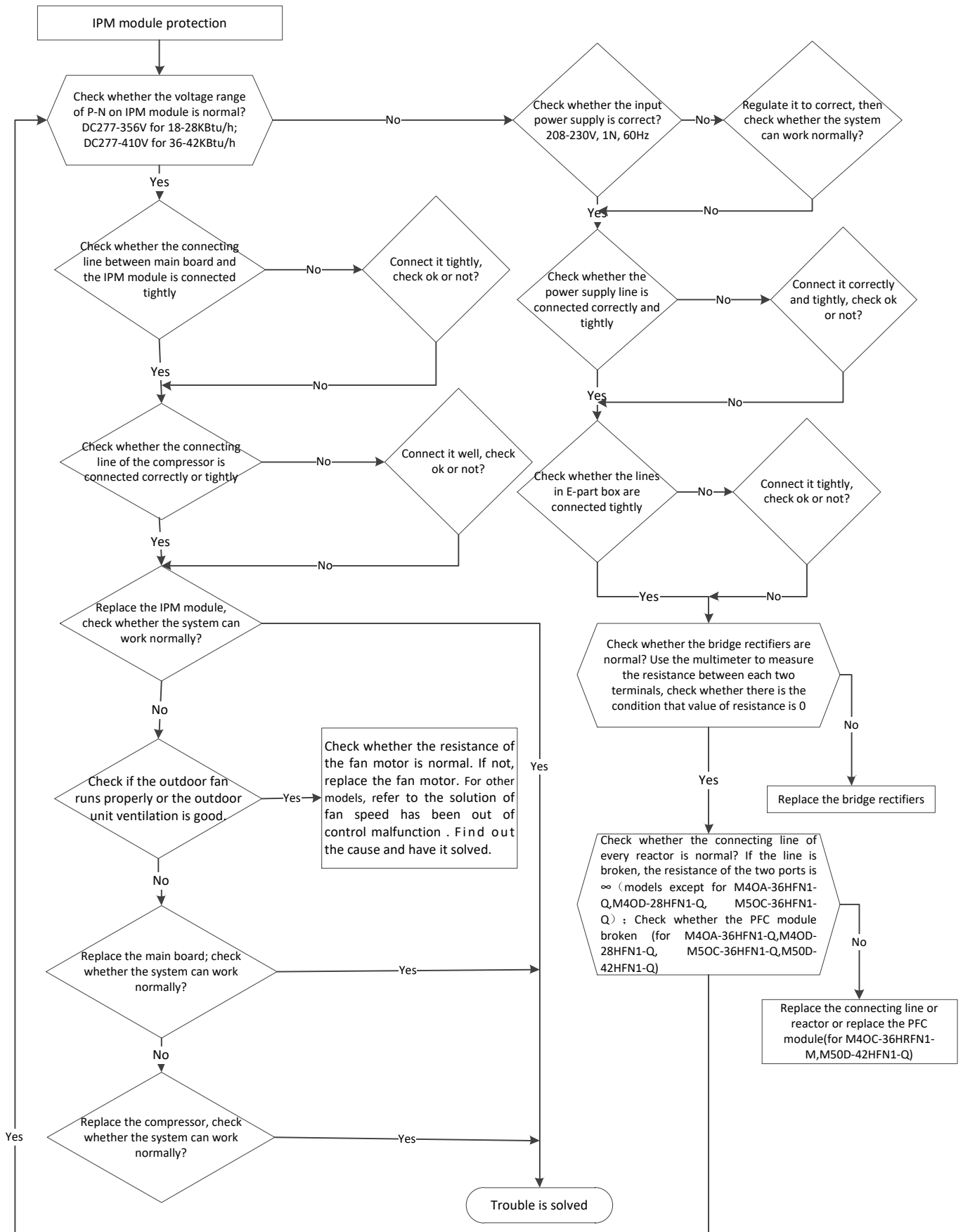

### 10.3.3.11 The cooling operation or heating operation does not operate.

**Potential causes**

- Faulty 4-way valve

Check of 4-way, please refer to part 5 in 10.4 Trouble Criterion Of Main Parts.

10.3.3.12 When cooling, heat exchanger of non-operating indoor unit frosts.

When heating, non-operating indoor unit get warm.

**Potential causes**

- Faulty EXV
- Wire and piping connected in reverse.

Check of EXV, please refer to part 6 in 10.4 Trouble Criterion Of Main Parts.

Automatic correction of wiring/piping error:

Press the "check switch" on the outdoor unit PCB board 5 seconds until LED display "CE", which mean this function is working, Approximately 5-10 minutes after the switch is pressed, the "CE" disappear the wiring/piping error will be corrected, and wiring/piping is properly connected.

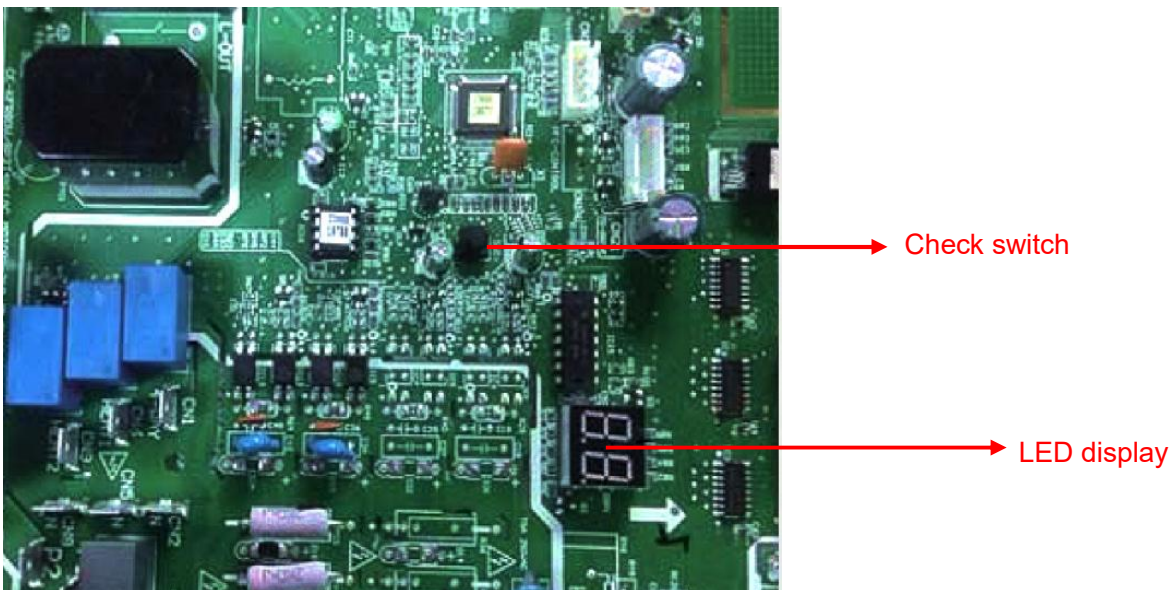

## 10.4 Main parts check

### 1. Temperature sensor checking

Disconnect the temperature sensor from PCB, measure the resistance value with a tester.

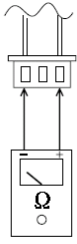

Tester

Temperature Sensors.

Room temperature(T1) sensor,

Indoor coil temperature(T2) sensor,

Outdoor coil temperature(T3) sensor,

Outdoor ambient temperature(T4) sensor,

Compressor discharge temperature(T5) sensor.

Measure the resistance value of each winding by using the multi-meter.

**Appendix 1 Temperature Sensor Resistance Value Table for T1,T2,T3,T4,T2B (°C--K)**

°C	K Ohm	°C	K Ohm	°C	K Ohm	°C	K Ohm
-20	115.266	20	12.6431	60	2.35774	100	0.62973
-19	108.146	21	12.0561	61	2.27249	101	0.61148
-18	101.517	22	11.5000	62	2.19073	102	0.59386
-17	96.3423	23	10.9731	63	2.11241	103	0.57683
-16	89.5865	24	10.4736	64	2.03732	104	0.56038
-15	84.2190	25	10.000	65	1.96532	105	0.54448
-14	79.3110	26	9.55074	66	1.89627	106	0.52912
-13	74.5360	27	9.12445	67	1.83003	107	0.51426
-12	70.1698	28	8.71983	68	1.76647	108	0.49989
-11	66.0898	29	8.33566	69	1.70547	109	0.48600
-10	62.2756	30	7.97078	70	1.64691	110	0.47256
-9	58.7079	31	7.62411	71	1.59068	111	0.45957
-8	56.3694	32	7.29464	72	1.53668	112	0.44699
-7	52.2438	33	6.98142	73	1.48481	113	0.43482
-6	49.3161	34	6.68355	74	1.43498	114	0.42304
-5	46.5725	35	6.40021	75	1.38703	115	0.41164
-4	44.0000	36	6.13059	76	1.34105	116	0.40060
-3	41.5878	37	5.87359	77	1.29078	117	0.38991
-2	39.8239	38	5.62961	78	1.25423	118	0.37956
-1	37.1988	39	5.39689	79	1.21330	119	0.36954
0	35.2024	40	5.17519	80	1.17393	120	0.35982
1	33.3269	41	4.96392	81	1.13604	121	0.35042
2	31.5635	42	4.76253	82	1.09958	122	0.3413
3	29.9058	43	4.57050	83	1.06448	123	0.33246
4	28.3459	44	4.38736	84	1.03069	124	0.32390
5	26.8778	45	4.21263	85	0.99815	125	0.31559
6	25.4954	46	4.04589	86	0.96681	126	0.30754
7	24.1932	47	3.88673	87	0.93662	127	0.29974
8	22.5662	48	3.73476	88	0.90753	128	0.29216
9	21.8094	49	3.58962	89	0.87950	129	0.28482
10	20.7184	50	3.45097	90	0.85248	130	0.27770
11	19.6891	51	3.31847	91	0.82643	131	0.27078
12	18.7177	52	3.19183	92	0.80132	132	0.26408
13	17.8005	53	3.07075	93	0.77709	133	0.25757
14	16.9341	54	2.95896	94	0.75373	134	0.25125
15	16.1156	55	2.84421	95	0.73119	135	0.24512
16	15.3418	56	2.73823	96	0.70944	136	0.23916
17	14.6181	57	2.63682	97	0.68844	137	0.23338
18	13.9180	58	2.53973	98	0.66818	138	0.22776
19	13.2631	59	2.44677	99	0.64862	139	0.22231

**Appendix 2** Temperature Sensor Resistance Value Table for T5 (°C--K)

°C	K Ohm	°C	K Ohm	°C	K Ohm	°C	K Ohm
-20	542.7	20	68.66	60	13.59	100	3.702
-19	511.9	21	65.62	61	13.11	101	3.595
-18	483	22	62.73	62	12.65	102	3.492
-17	455.9	23	59.98	63	12.21	103	3.392
-16	430.5	24	57.37	64	11.79	104	3.296
-15	406.7	25	54.89	65	11.38	105	3.203
-14	384.3	26	52.53	66	10.99	106	3.113
-13	363.3	27	50.28	67	10.61	107	3.025
-12	343.6	28	48.14	68	10.25	108	2.941
-11	325.1	29	46.11	69	9.902	109	2.86
-10	307.7	30	44.17	70	9.569	110	2.781
-9	291.3	31	42.33	71	9.248	111	2.704
-8	275.9	32	40.57	72	8.94	112	2.63
-7	261.4	33	38.89	73	8.643	113	2.559
-6	247.8	34	37.3	74	8.358	114	2.489
-5	234.9	35	35.78	75	8.084	115	2.422
-4	222.8	36	34.32	76	7.82	116	2.357
-3	211.4	37	32.94	77	7.566	117	2.294
-2	200.7	38	31.62	78	7.321	118	2.233
-1	190.5	39	30.36	79	7.086	119	2.174
0	180.9	40	29.15	80	6.859	120	2.117
1	171.9	41	28	81	6.641	121	2.061
2	163.3	42	26.9	82	6.43	122	2.007
3	155.2	43	25.86	83	6.228	123	1.955
4	147.6	44	24.85	84	6.033	124	1.905
5	140.4	45	23.89	85	5.844	125	1.856
6	133.5	46	22.89	86	5.663	126	1.808
7	127.1	47	22.1	87	5.488	127	1.762
8	121	48	21.26	88	5.32	128	1.717
9	115.2	49	20.46	89	5.157	129	1.674
10	109.8	50	19.69	90	5	130	1.632
11	104.6	51	18.96	91	4.849		
12	99.69	52	18.26	92	4.703		
13	95.05	53	17.58	93	4.562		
14	90.66	54	16.94	94	4.426		
15	86.49	55	16.32	95	4.294	B(25/50)=3950K	
16	82.54	56	15.73	96	4.167		
17	78.79	57	15.16	97	4.045	R(90°C)=5KΩ±3%	
18	75.24	58	14.62	98	3.927		
19	71.86	59	14.09	99	3.812		

## 2.Compressor checking

Measure the resistance value of each winding by using the tester.

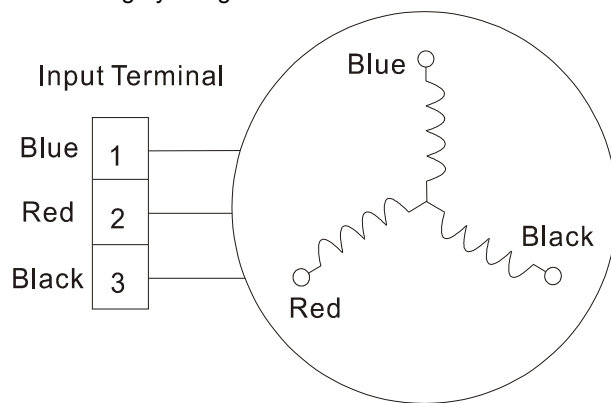

Position	Resistance Value			
	ASN108D22UEZ	ASM135D23UFZ	ATF235D22UMT	ATF310D43UMT
Blue - Red	1.57Ω(20°C)	1.75Ω(20°C)	0.75Ω(20°C)	0.65Ω(20°C)



### 3. IPM continuity check

Turn off the power, let the large capacity electrolytic capacitors discharge completely, and dismount the IPM. Use a digital tester to measure the resistance between P and UVWN; UVW and N.

Digital tester		Normal resistance value	Digital tester		Normal resistance value
(+)Red	(-)Black		(+)Red	(-)Black	
P	N	∞ (Several MΩ)	U	N	∞ (Several MΩ)
	U		V		
	V		W		
	W		(+)Red		

### 4: Indoor AC Fan Motor

Measure the resistance value of each winding by using the tester.

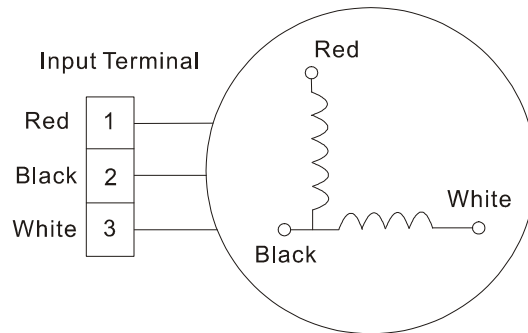

Position	Resistance Value
	YKSS-68-4-15-1 (Weiling)
Black - Red	285.8Ω±8% (20°C)
Red - Yellow	178.5Ω±8% (20°C)
Yellow - Blue	178.5Ω±8% (20°C)



## 5.4-way valve

1. Power on, use a digital tester to measure the voltage, when the unit operates in cooling, it is 0V. When the unit operates in heating, it is about 230VAC.

If the value of the voltage is not in the range, the PCB must have problems and need to be replaced.

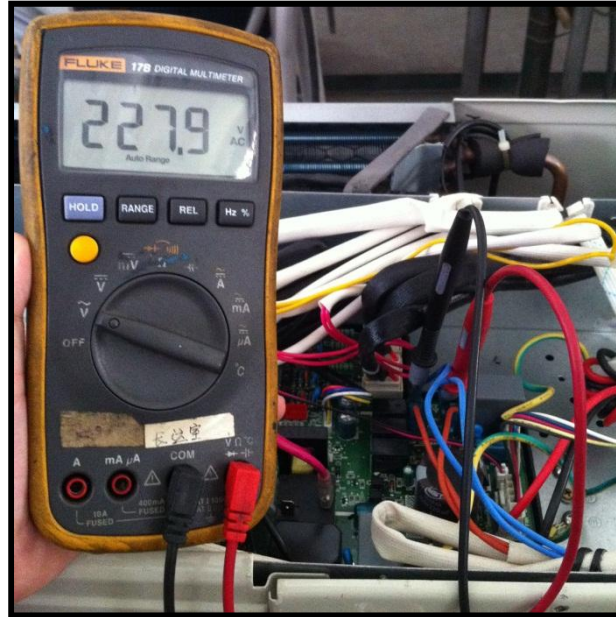

2 Turn off the power, use a digital tester to measure the resistance. The value should be 1.8~2.5 KΩ.

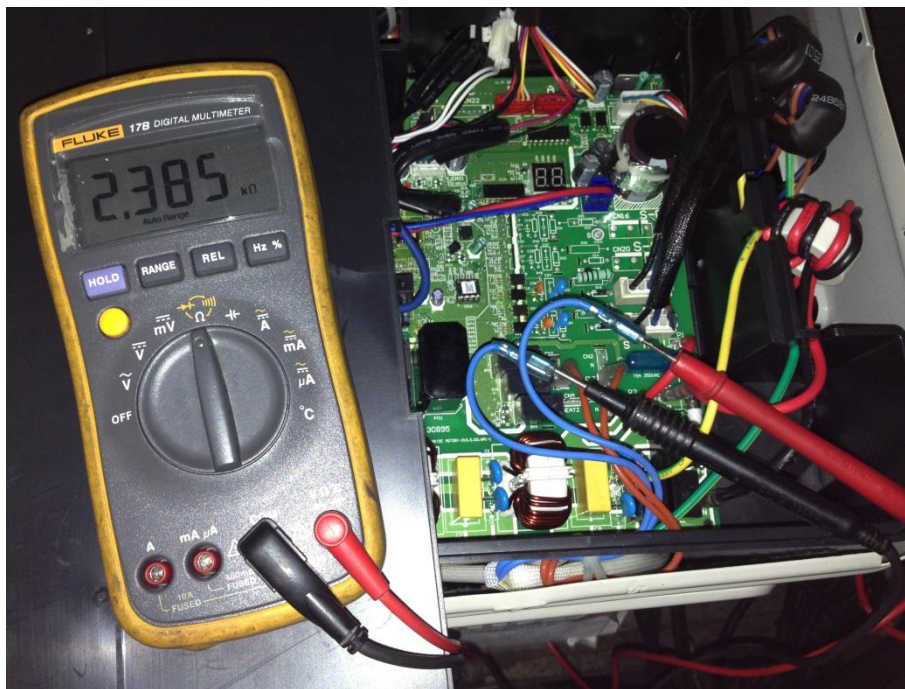

## 6.EXV check

Disconnect the connectors.

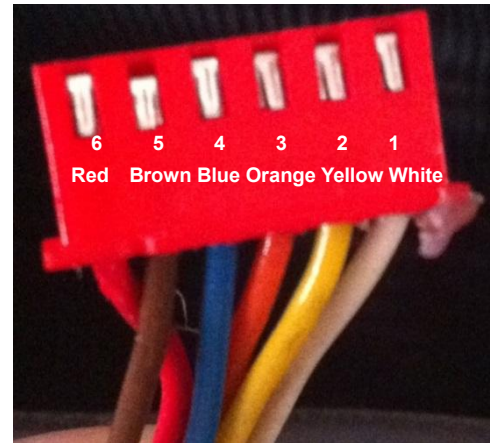
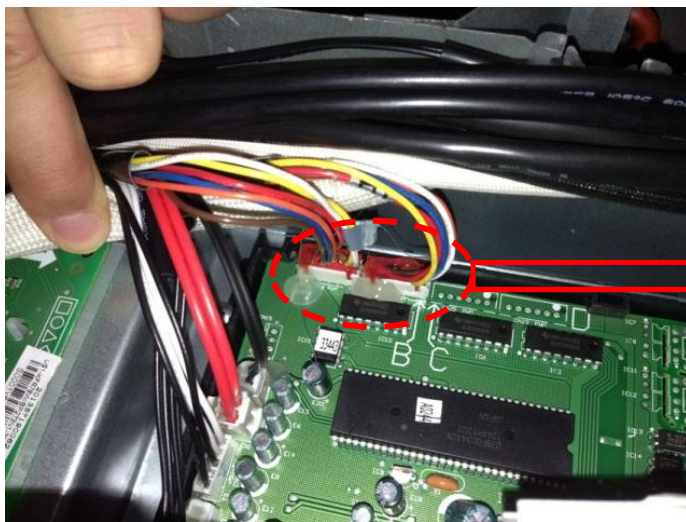
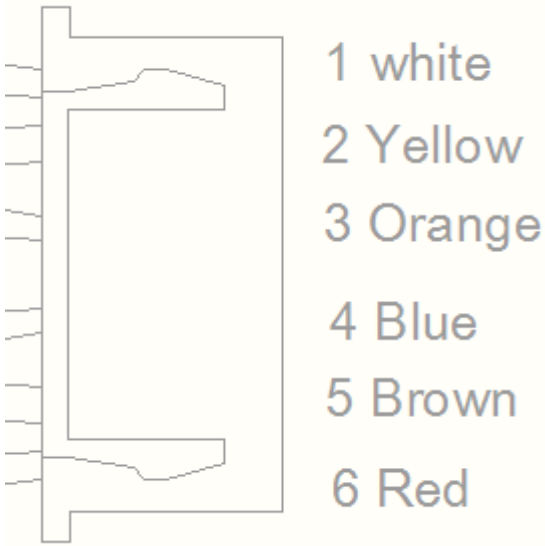

### Resistance to EXV coil

Color of lead wire	Normal Value
Red- Blue	About 50Ω
Red - Yellow	
Brown-Orange	

