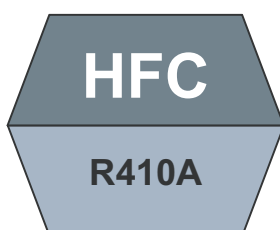


PRODUCT NAME: iFlex Plus VRF



### OUTDOOR UNIT

575IVQ008H1900  
575IVQ010H1900  
575IVQ012H1900  
575IVQ014H1900  
575IVQ016H1900





**CONTENT**

**PAGE**

<b>1. PRECAUTIONS.....</b>	<b>1</b>
<b>2. OUTDOOR UNIT.....</b>	<b>2</b>
2.1 Construction checkpoints.....	2
2.2 Accessories.....	3
2.3 Outdoor unit installation.....	3
2.4 Refrigerant pipe.....	6
2.5 Electric wiring.....	11
2.6 Trial run.....	15

# 1. PRECAUTIONS

Precautions before reading the Installation manual.

- This Installation manual is for the outdoor unit.
- Refer to the indoor unit Installation manual for indoor parts installation.
- Please read the power source unit Installation manual to install the power source unit.
- Please refer to the refrigerant distributor Installation manual to install the refrigerant distributor.

The safety precautions listed here are divided into two categories. In either case, important safety information is listed which must be read carefully.



## WARNING

Failure to observe a warning may result in death. The appliance shall be installed in accordance with national wiring regulations.



## CAUTION

Failure to observe a caution may result in injury or damage to the equipment.

After completing the installation, make sure that the unit operates properly during the start-up operation. Please instruct the customer on how to operate the unit and keep it trained. Also, inform customers that they should store this Installation manual along with the owner's manual for future reference.



## WARNING

- **Be sure only trained and qualified service personnel to install, repair or service the equipment.**  
Improper installation, repair, and maintenance may result in electric shocks, short-circuit, leaks, fire or other damage to the equipment.
- **Install according to this installation instructions strictly.**  
If installation is defective, it will cause water leakage, electrical shock fire.
- **When installing the unit in a small room, take measures against to keep refrigerant concentration from exceeding allowable safety limits in the event of refrigerant leakage.**  
Contact the place of purchase for more information. Excessive refrigerant in a closed ambient can lead to oxygen deficiency.
- **Use the attached accessories parts and specified parts for installation.**  
Otherwise, it will cause the set to fall, water leakage, electrical shock fire.
- **Install at a strong and firm location which is able to withstand the set's weight.**  
If the strength is not enough or installation is not properly done, the set will drop to cause injury.
- **The appliance shall be installed in accordance with national wiring regulations**
- **The appliance must be installed 2.5m above floor.**
- **The appliance shall not be installed in the laundry.**
- **Before obtaining access to terminals, all supply circuits must be disconnected.**
- **The appliance must be positioned so that the plug is accessible.**
- **The enclosure of the appliance shall be marked by word, or by symbols, with the direction of the fluid flow.**
- **For electrical work, follow the local national wiring standard, regulation and this installation instructions. An independent circuit and single outlet must be used.**  
If electrical circuit capacity is not enough or defect in electrical work, it will cause electrical shock fire.
- **Use the specified cable and connect tightly and clamp the cable so that no external force will be acted on the terminal.**  
If connection or fixing is not perfect, it will cause heat-up or fire at the connection.
- **Wiring routing must be properly arranged so that control board cover is fixed properly.**  
If control board cover is not fixed perfectly, it will cause heat-up at connection point of terminal, fire or electrical shock.
- **If the supply cord is damaged, it must be replaced by the manufacture or its service agent or similarly qualified person in order to avoid a hazard.**
- **An all-pole disconnection device which has at least 3mm separation distance in all pole and a residual current device(RCD)with the rating of above 10mA shall be incorporated in the fixed wiring according to the national rule**
- **When carrying out piping connection, take care not to let air substances go into refrigeration cycle.**  
Otherwise, it will cause lower capacity, abnormal high pressure in the refrigeration cycle, explosion and injury.
- **Do not modify the length of the power supply cord or use of extension cord, and do not share the single outlet with other electrical appliances.**  
Otherwise, it will cause fire or electrical shock.
- **Carry out the specified installation work after taking into account strong winds, typhoons or earthquakes.**  
Improper installation work may result in the equipment falling and causing accidents.
- **The temperature of refrigerant circuit will be high, please keep the interconnection cable away from the copper tube.**
- **The power cord type designation is H07RN-F.**
- **Equipment complying with IEC 61000-3-12.**
- **If the refrigerant leaks during installation, ventilate the area immediately.**  
Toxic gas may be produced if the refrigerant comes into the place contacting with fire.
- **After completing the installation work, check that the refrigerant does not leak.**  
Toxic gas may be produced if the refrigerant leaks into the room and comes into contact with a source of fire, such as a fan heater, stove or cooker.





## CAUTION

- **The cooling&heating indoor unit is applicable for the cooling&heating and the cooling only outdoor unit;the heating capacity of the indoor unit will be effective only when the indoor unit connect to the cooling&heating outdoor unit.**
- **This A/C is a kind of amenity unit. Don't install it at the place where for storing machine, precise instrument, food, plant, animal, artwork or any other special used occasion.**
- **Ground the air conditioner.**  
Do not connect the ground wire to gas or water pipes, lightning rod or a telephone ground wire. Incomplete grounding may result in electric shocks.
- **Be sure to install an earth leakage breaker.**  
Failure to install an earth leakage breaker may result in electric shocks.
- **Connect the outdoor unit wires , then connect the indoor unit wires.**  
You are not allowed to connect the air conditioner with the power source until wiring and piping the air conditioner is done.
- **While following the instructions in this Installation manual, install drain piping in order to ensure proper drainage and insulate piping in order to prevent condensation.**  
Improper drain piping may result in water leakage and property damage.
- **Install the indoor and outdoor units, power supply wiring and connecting wires at least 1 meter away from televisions or radios in order to prevent image interference or noise.**  
Depending on the radio waves, a distance of 1 meter may not be sufficient enough to eliminate the noise.
- **The appliance is not intended for use by young children or infirm persons without supervision.**
- **Young children should be supervised to ensure that they do not play with the appliance.**
- **Don't install the air conditioner in the following locations:**
  - There is petrolatum existing.
  - There is salty air surrounding (near the coast).
  - There is caustic gas (the sulfide, for example) existing in the air (near a hot spring).
  - The Volt vibrates violently (in the factories).
  - In buses or cabinets.
  - In kitchen where it is full of oil gas.
  - There is strong electromagnetic wave existing.
  - There are inflammable materials or gas.
  - There is acid or alkaline liquid evaporating.
  - Other special conditions.
- **The insulation of the metal parts of the building and the air conditioner should comply with the regulation of National Electric Standard.**

## 2. OUTDOOR UNIT






### 2.1 Construction checkpoints

- Acceptance and Unpacking
  - After the machine arrives, check whether it is damaged during the shipment. If the surface or inner side of the machine is damaged, submit a written report to the shipping company.
  - Check whether the model, specification and quantity of the equipment conform to the contract.
  - After removing the outer package, please keep the operation instructions well and count the accessories.
- Refrigerant pipe
  - Check the model and name to avoid mistaken installation.
  - An additionally purchased refrigerant distributor (manifold adapter and manifold pipe) must be used for installing the refrigerant pipes.
  - The refrigerant pipes must have the specified diameter. Nitrogen of a certain pressure must be filled into the refrigerant pipe before welding.
  - The refrigerant pipe must undergo heat insulation treatment.
  - After the refrigerant pipe is installed completely, the indoor unit cannot be powered on before performing the airtight test and creating a vacuum. The air-side and liquid-side pipes must undergo the airtight test and vacuum extraction.
- Airtight test  
The refrigerant pipe must undergo the airtight test [with 2.94 MPa(30kgf/cm<sup>2</sup>) nitrogen].
- Creating a vacuum  
Be sure to use the vacuum pump to create a vacuum of the connective pipe at the air side and liquid side concurrently.
- Refrigerant replenishment
  - If the length is greater than the reference pipe, the refrigerant replenishment quantity for each system should be calculated through the formula obtained according to the actual length of pipe.
  - Record the refrigerant replenishment quantity, actual length of pipe and the height difference of the indoor & outdoor unit onto the operation confirmation table of the outdoor unit in advance for future reference.
- Electric wiring
  - Select the power supply capacity and wire size according to the design manual. The power cable of the air conditioner is generally thicker than the power cable of the motor.
  - In order to prevent misoperation of the air conditioner, do not interleave or entwine the power cablewith the connection wires (low-voltage wires) of the indoor/outdoor unit.
  - Power on the indoor unit after performing the airtight test and making a vacuum.
  - For details of setting the address of the outdoor unit, see Outdoor unit address bits.

- Trial run
- Before operation, remove the six pieces of PE foaming which are used at the rear of the unit for protecting the condenser. Be careful not to damage the fin. Otherwise, the heat exchange performance may be affected.
- Perform the trial run only after the outdoor unit has been powered on for over 12 hours.

## 2.2. Accessories

Table.2-1

Name	Model	All of units	Outline	Function
Outdoor unit installation manual		1		_____
Outdoor unit owner's manual		1		Be sure to deliver it to the customer
Indoor unit owner's manual		1		Be sure to deliver it to the customer
Toggling flathead screw		1	_____	For toggling of indoor and outdoor units
Gauge point subassembly		1		For purpose of airtight test
90° mouting elbow		1	_____	For connecting pipes
Seal plug		8	_____	For pipe Cleaning
Connective pipe accessory		1		Connect to the side of liquid pipe
Bolt bage		1	_____	Stone for service

## 2.3. Outdoor unit installation

### 2.3.1 Outdoor unit combination

Table.2-2

HP	Mode	Qty.of indoor unit	HP	Mode	Qty.of indoor unit
8	8HP×1	17	22	10HP+12HP	47
10	10HP×1	21	24	10HP+14HP	52
12	12HP×1	26	26	10HP+16HP	56
14	14HP×1	30	28	14HP×2	60
16	16HP×1	34	30	14HP+16HP	64
18	8HP+10HP	39	32	16HP+16HP	64
20	10HP+10HP	43	34	10HP×2+14HP	64

Table.2-3

HP	Mode	Qty.of indoor unit	HP	Mode	Qty.of indoor unit
36	10HP×2+16HP	64	52	10HP×2+16HP×2	64
38	10HP+12HP+16HP	64	54	10HP+12HP+16HP×2	64
40	10HP+14HP+16HP	64	56	10HP+14HP+16HP×2	64
42	14×3	64	58	14HP×3+16HP	65
44	14HP×2+16HP	64	60	14HP×2+16HP×2	64
46	14HP+16HP×2	64	62	14HP+16HP×3	64
48	16HP×3	64	64	16HP×4	64
50	8HP+10HP+16HP×2	64			

### 2.3.2 Dimension of outdoor unit

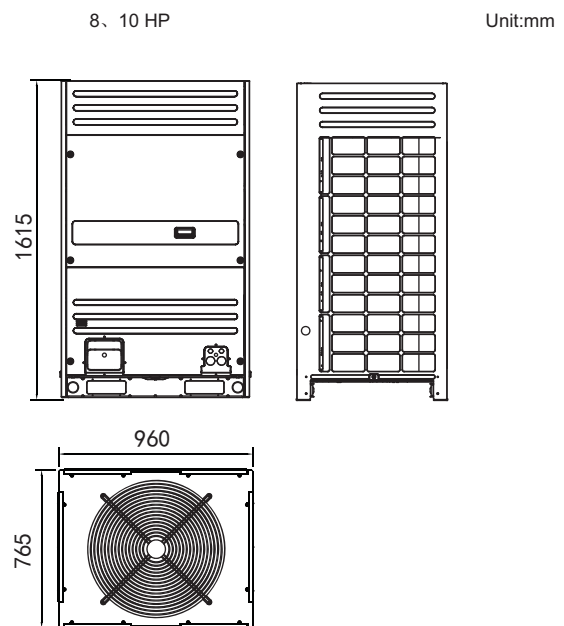


Fig.2-1

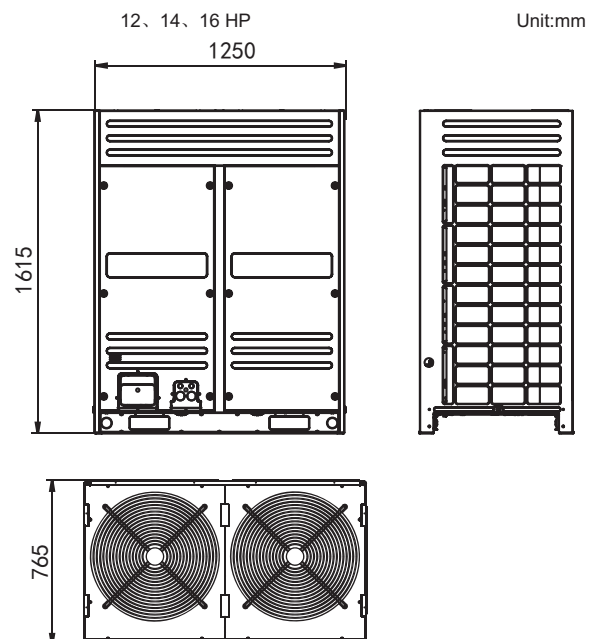


Fig.2-2

### 2.3.3 Selecting installation position

- Ensure that the outdoor unit is installed in a dry, well-ventilated place.
- Ensure that the noise and exhaust ventilation of the outdoor unit do not affect the neighbors of the property owner or the surrounding ventilation.
- Ensure that the outdoor unit is installed in a well-ventilated place that is possibly closest to the indoor unit.
- Ensure that the outdoor unit is installed in a cool place without direct sunshine exposure or direct radiation of high-temp heat source.
- Do not install the outdoor unit in a dirty or severely polluted place, so as to avoid blockage of the heat exchanger in the outdoor unit.
- Do not install the outdoor unit in a place with oil pollution, salt or high content of harmful gases such as sulfurous gas.

### 2.3.4 Base for outdoor unit

- A solid, correct base can:
  - Avoid the outdoor unit from sinking.
  - Avoid the abnormal noise generated due to base.
- Base types
  - Steel structure base
  - Concrete base (see the figure below for the general making method)

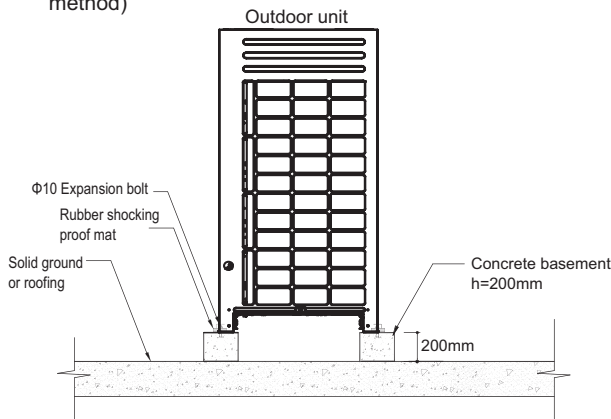


Fig.2-3



### CAUTION

- The key points to make basement:
  - The master unit's basement must be made on the solid concrete ground. Refer to the structure diagram to make concrete basement in detail, or make after field measurements.
  - In order to ensure every point can contact equality, the basement should be on completely level.
  - If the basement is placed on the roofing, the detritus layer isn't needed, but the concrete surface must be flat. The standard concrete mixture ratio is cement 1/ sand 2/ carpolite 4, and add Φ10 strenthen reinforcing steel bar, the surface of the cement and sand plasm must be flat, border of the the basement must be chamfer angle.

- Before construct the unit base, please ensure the base is directly supporting the rear and front folding edges of the bottom panel vertically, for the reason of these edges are the actual supported sites to the unit.
- In order to drain off the seeper around the equipment, a discharge ditch must be setup around the basement.
- Please check the affordability of the roofing to ensure the load capacity.
- When piping from the bottom of the unit, the base height should no less than 200mm.

- Position illustration of screw bolt (Unit: mm)

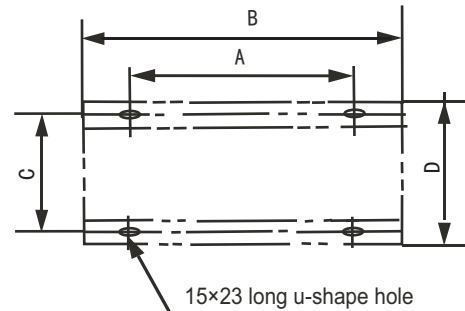


Fig.2-4

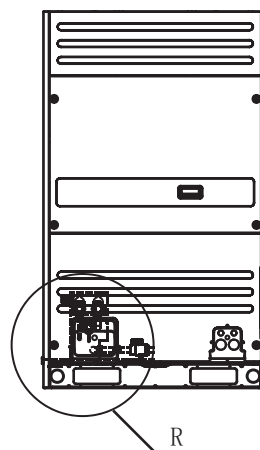
Table.2-4

Unit: mm

HP SIZE	8,10	12, 14, 16
A	830	1120
B	960	1250
C	736	736
D	765	765

- Centering position illustration of each connective pipe (Unit: mm)

#### 1) 8HP, 10HP



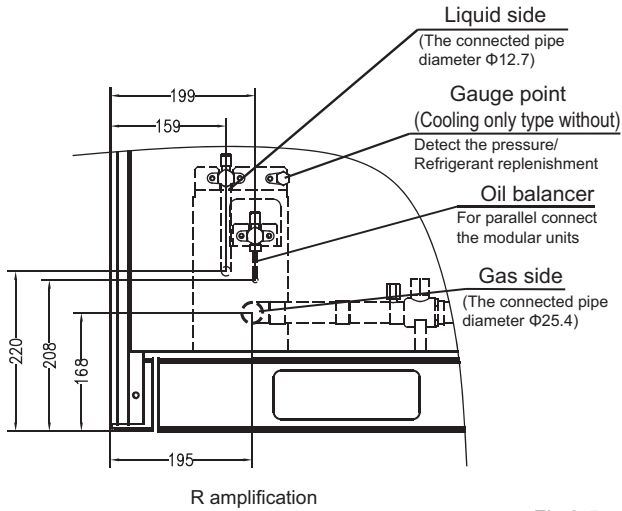


Fig.2-5

2) 12HP, 14HP, 16HP

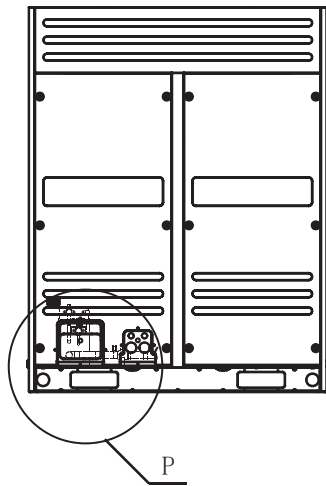


Fig.2-6

### 2.3.5 Outdoor units' placement sequence & master and slave units' settings

A system, which provide with more than two outdoor units, will be set as the followings method: The outdoor units in this system should place sequentially from the large to the small capacity; the largest capacity outdoor unit must be mounted at the first branching site; and set the largest capacity outdoor unit address as the master Unit, while the other setting as the Slave Unit. Take 40HP (composed by 10HP, 14HP and 16HP) as an example:

- 1) Place the 16HP at a side of the first branching site.
- 2) Place the unit from the large capacity to the small (See the detail placement illustration)
- 3) Set 16HP as the master unit, while the 14HP and the 10HP as the aux. unit.

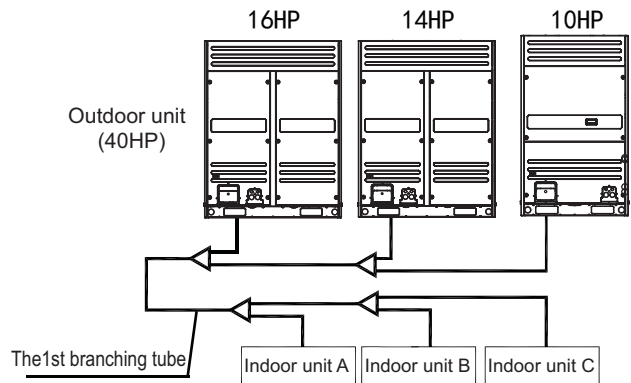
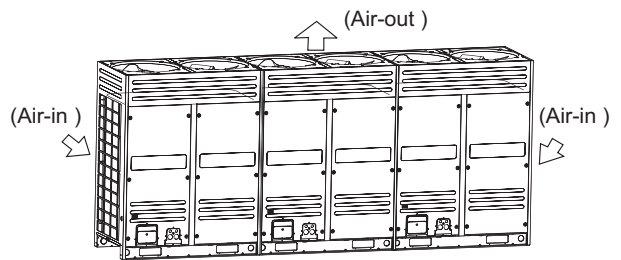


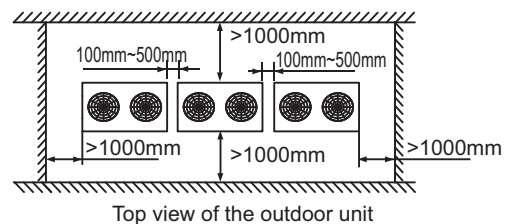
Fig.2-7

### 2.3.6 Installation space for outdoor unit

- Ensure enough space for maintenance. The modules in the same system must be on the same height.(see the Fig.2-8)
- When installing the unit, leave a space for maintenance shown in Fig.2-9. Install the power supply at the side of the outdoor unit. For installation procedure, see the power supply device Installation manual.
- In case any obstacles exist above the outdoor unit, refer to Fig.2-14.



Installation and maintenance surface Fig.2-8



Top view of the outdoor unit

Fig.2-9

### 2.3.7 Layout

- When the outdoor unit is higher than the surrounding obstacle
- One row

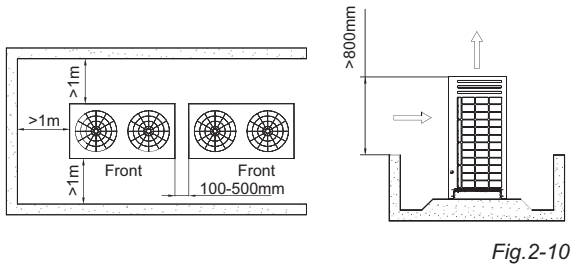


Fig.2-10

- Two rows

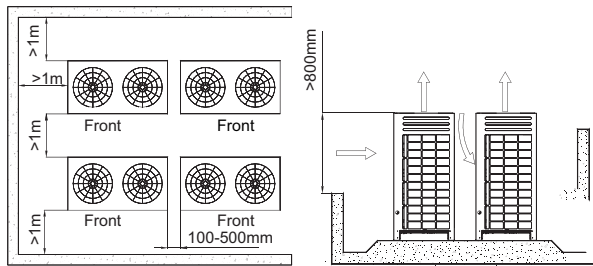


Fig.2-11

- More than two rows

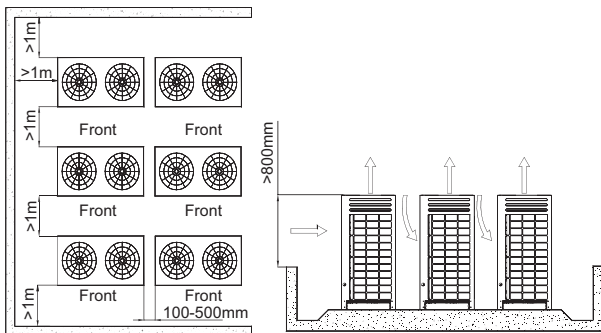


Fig.2-12

- When the outdoor unit is lower than the surrounding obstacle, refer to the layout used when the outdoor unit is higher than the surrounding obstacle. However, to avoid cross connection of the outdoor hot air from affecting the heat exchange effect, please add an air director onto the exhaust hood of the outdoor unit to facilitate heat dissipation. See the figure below. The height of the air director is HD (namely H-h). Please make the air director on site.

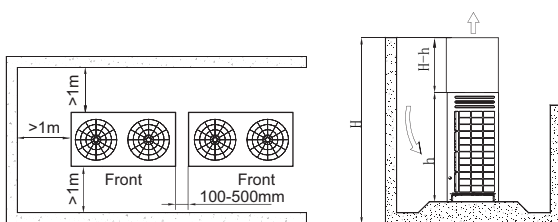


Fig.2-13

- If miscellaneous articles are piled around the outdoor unit, such articles must be 800mm below the top of the outdoor unit. Otherwise, a mechanic exhaust device must be added.

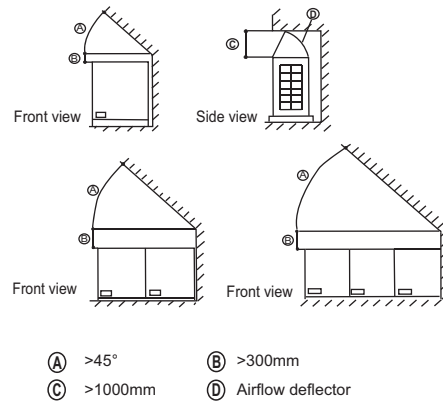


Fig.2-14

### 2.3.8 Set the snow-proof facility

- In snowy areas, facilities should be installed to prevent snow. (See the figure below) (defective facilities may cause malfunction.) Please lift the bracket higher and install snow shed at the air inlet and air outlet.

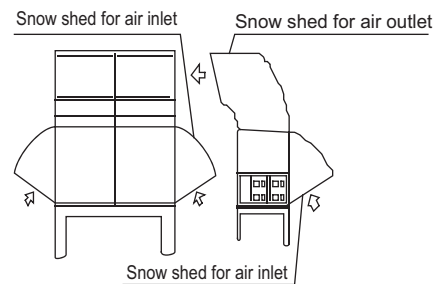
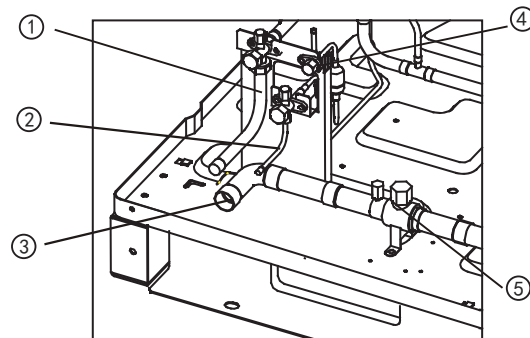


Fig.2-15

### 2.3.9 Explanation of valve



Note: For a single modular that is not necessary to connect with oil balancer.

Fig.2-16

Table.2-5

①	Connect the liquid pipe (accessory, field installation)
②	Oil balancer
③	Connect the gas pipe
④	Gauge point(Cooling only type without)
⑤	Low pressure float valve

### 2.3.10 Mount the air deflector

(If the static pressure of outdoor unit is over 20Pa, The unit need be customized.)

■ 8HP, 10HP Installation illustration

Example A

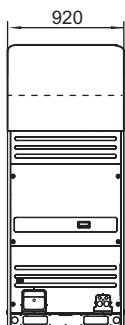


Fig. 2-17

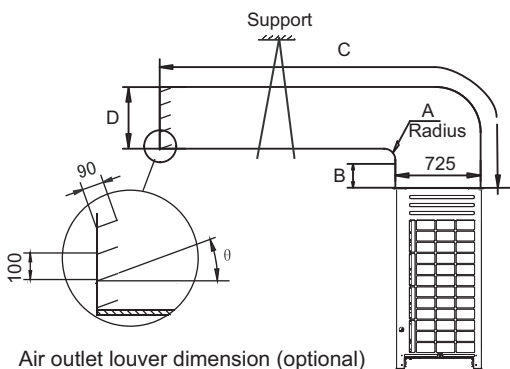


Fig. 2-18

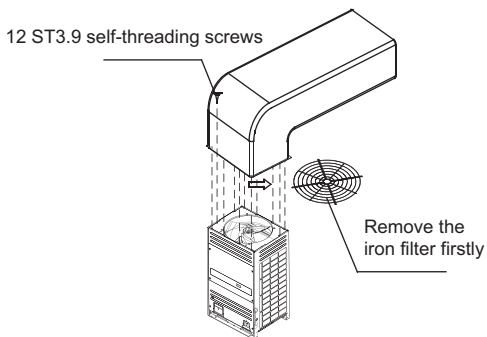


Fig. 2-19

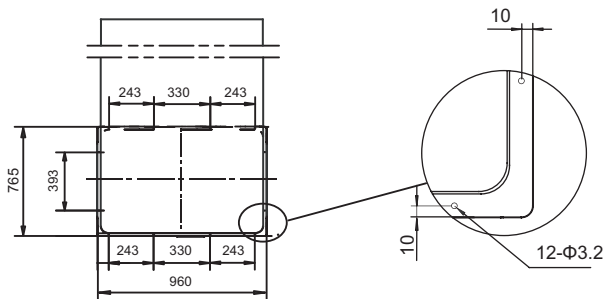
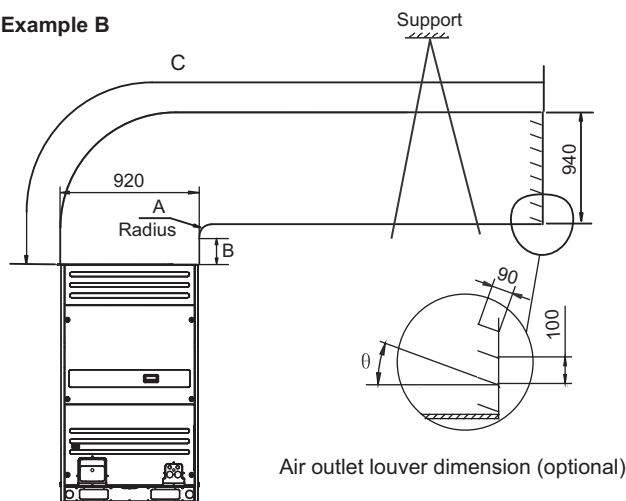


Fig. 2-20

Table.2-6 Unit: mm

A	$A \geq 300$
B	$B \geq 250$
C	$C \leq 8000$
D	$600 \leq D \leq 760$
$\theta$	$\theta \leq 15^\circ$

Example B



Air outlet louver dimension (optional)

Fig. 2-21

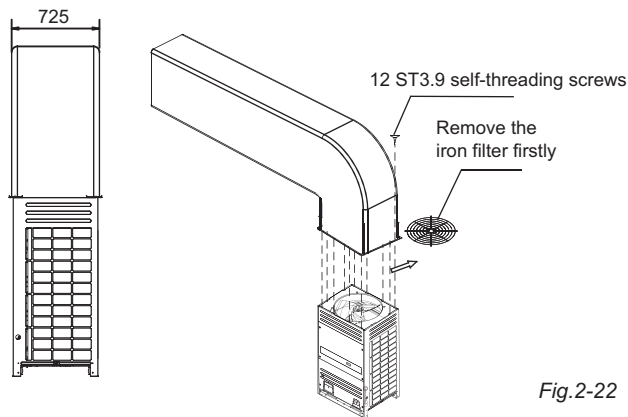


Fig. 2-22

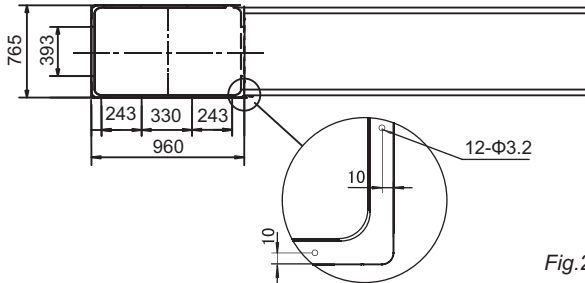
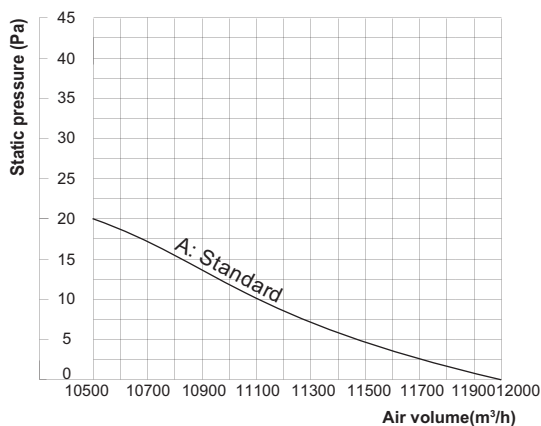


Fig. 2-23

Table.2-7 Unit: mm

A	$A \geq 300$
B	$B \geq 250$
C	$C \leq 8000$
$\theta$	$\theta \leq 15^\circ$

■ Curve diagram of static pressure, air flow volum.



■ 12HP, 14HP, 16HP Installation illustration

Example A

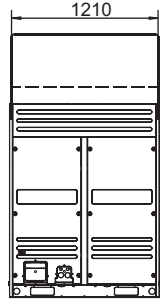
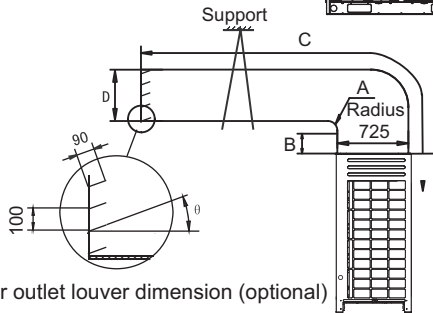


Fig.2-24



Air outlet louver dimension (optional)

12 ST3.9 self-threading screws

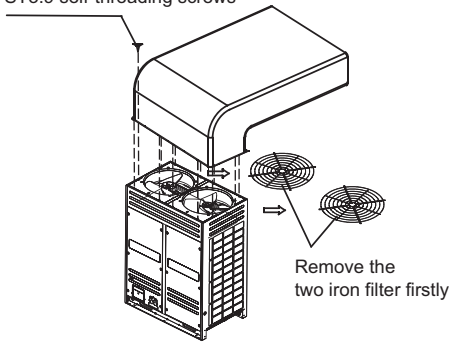


Fig.2-25

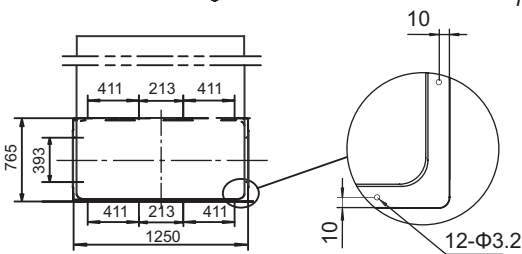
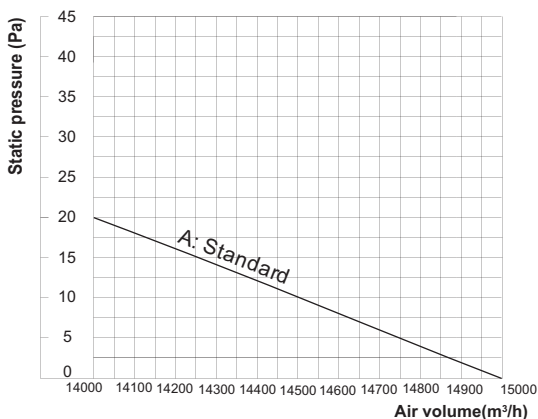


Fig.2-26

Table.2-8 Unit: mm

A	$A \geq 300$
B	$B \geq 250$
C	$C \leq 8000$
D	$600 \leq D \leq 760$
$\theta$	$\theta \leq 15^\circ$

■ Curve diagram of static pressure, air flow volum.



Example B

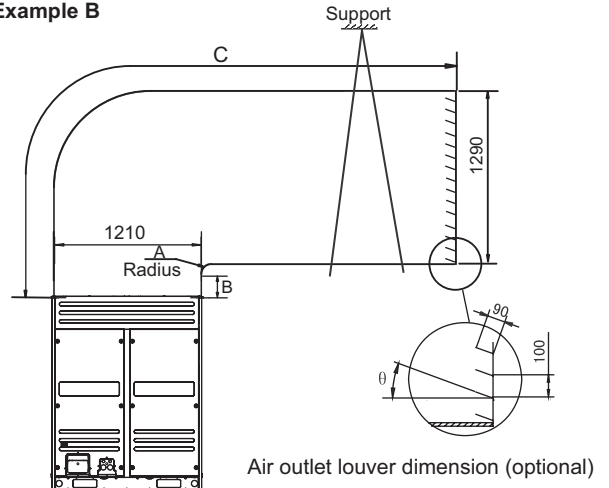


Fig.2-28

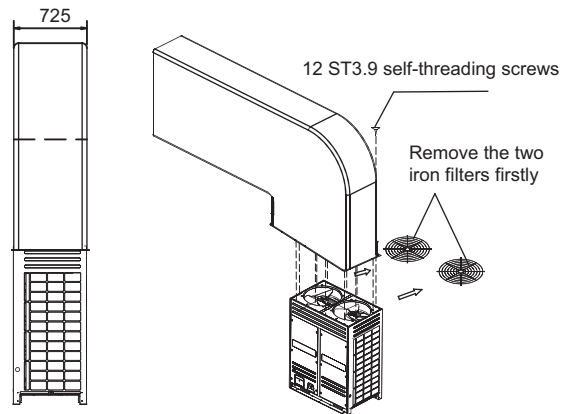


Fig.2-29

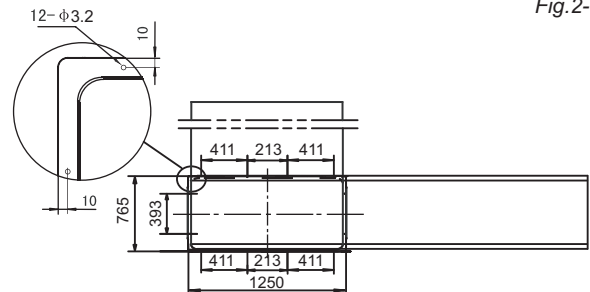


Fig.2-30

Table.2-9 Unit: mm

A	$A \geq 300$
B	$B \geq 250$
C	$C \leq 8000$
$\theta$	$\theta \leq 15^\circ$

**NOTE**

Before install the air deflector, please ensuring the mesh enclosure has been took off, otherwise the air supply efficiency would be block down.

Once mounting the shutter to the unit, air volume, cooling (heating) capacity and efficiency would be block down, this affection enhance along with the angle of the shutter. Thus, we are not recommend you to mount the shutter, if necessary in use, please adjust the angle of shutter no larger than 15°.

Only one bending site to be allowed in the air duct (see as above figure), otherwise, misoperation may led out.



## 2.4. REFRIGERANT PIPE

### 2.4.1 Length and drop height permitted of the refrigerant piping

Note: Reduced length of the branching tube is the 0.5m of the equivalent length of the pipe.

Table.2-10

		Permitted value		Piping
Pipe length	Total pipe length (Actual)	<30HP	350m	L1+L2+L3+L4 +L5+L6+L7+L8 +L9+a+b+c+d +e+f+g+h+i+j
		>30HP	500m	
	Maximum piping (L)	Actual length	150m	L1+L5+L8+L9 +j
		Equivalent length	175m	
Piping (farthest from the first line pipe branch) equivalent length		40m		L5+L8+L9+j
Drop height	Indoor unit-outdoor unit drop height	Outdoor unit up	70m (*1 Available on request)	—
		Outdoor unit down	70m	—
	Indoor unit to indoor unit drop height	15m		—

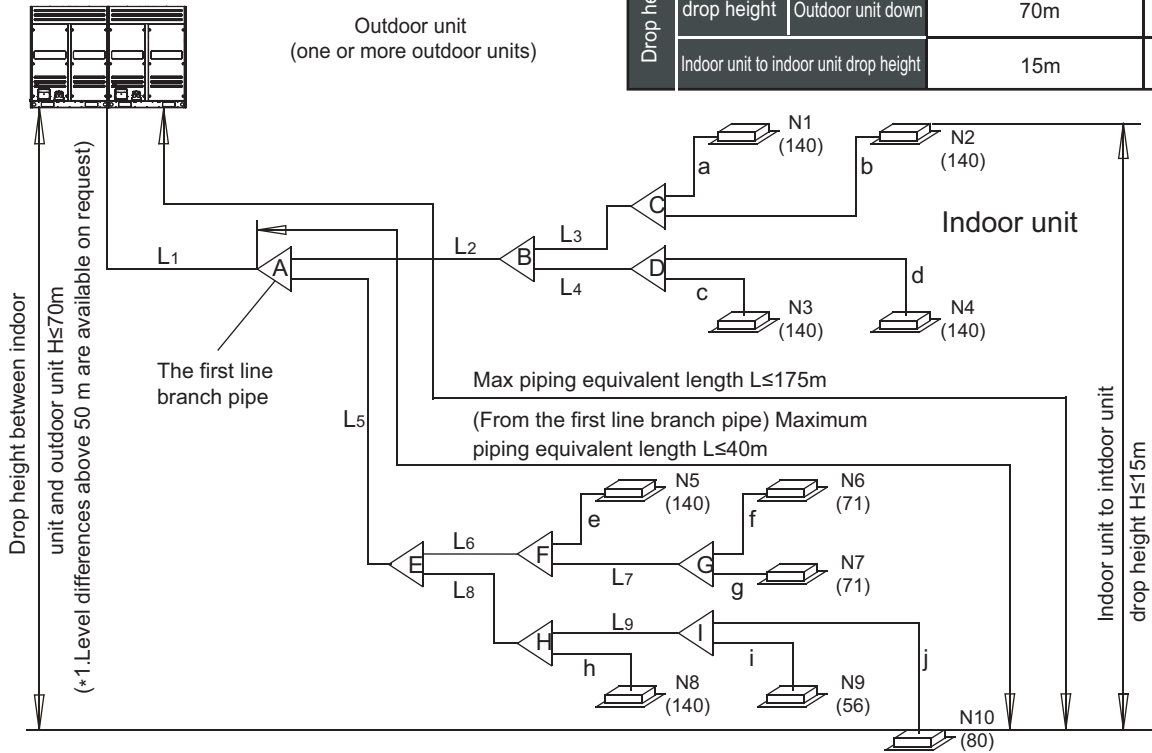


Fig.2-31

\*1.Level difference above 50m are not supported by default but are available on request for customized.(if the outdoor unit is above the indoor unit.)

### 5.2 Select the refrigerant piping type

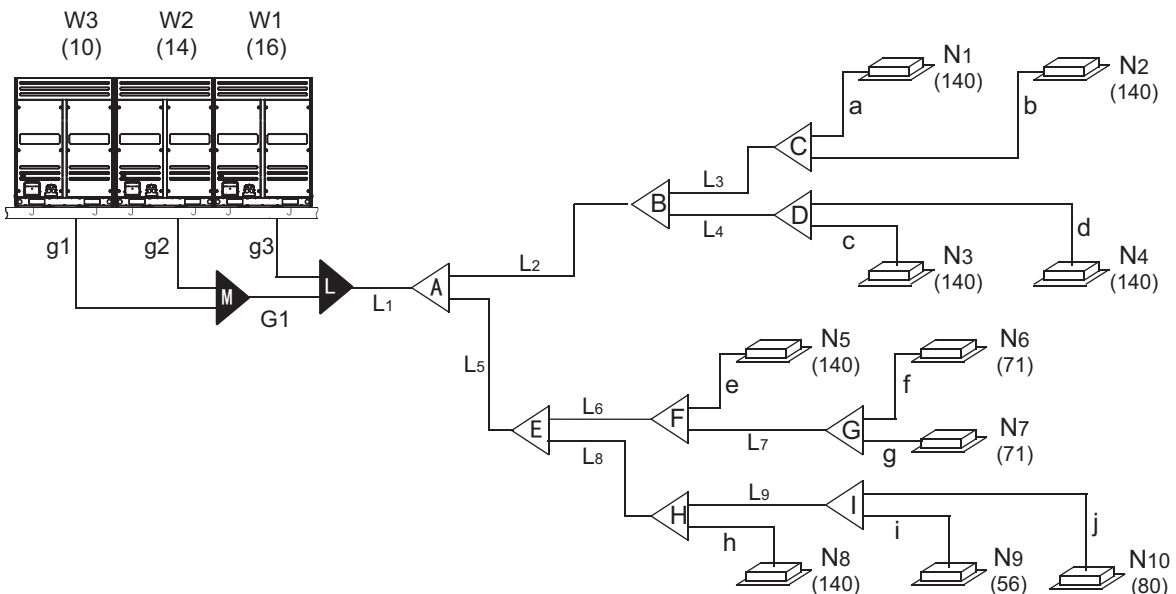


Fig.2-32



Table.2-11

Pipe name	Code (As per the Fig. 5-2)
Main pipe	L1
Indoor unit main pipe	L2~L9
Indoor unit aux. pipe	a, b, c, d, e, f, g, h, i, j
Indoor unit branching pipe assembly	A, B, C, D, E, F, G, H, I
Outdoor unit branching pipe assembly	L, M
Outdoor unit connective pipe	g1, g2, g3, G1

### 2.4.3 Size of joint pipes for indoor unit

Size of joint pipes for 410A indoor unit

Table.2-12

Capacity of indoor unit (A)	Size of main pipe(mm)		
	Gas side	Liquid side	Available branching pipe
A<166	Φ19.1	Φ9.5	SQZHN-01(i)
166≤A<230	Φ22.2	Φ9.5	SQZHN-02(i)
230≤A<330	Φ22.2	Φ12.7	SQZHN-02(i)
330≤A<460	Φ28.6	Φ12.7	SQZHN-03(i)
460≤A<660	Φ28.6	Φ15.9	SQZHN-03(i)
660≤A<920	Φ34.9	Φ19.1	SQZHN-04(i)
920≤A<1350	Φ41.3	Φ19.1	SQZHN-05(i)
1350≤A	Φ44.5	Φ22.2	SQZHN-05(i)

e.x.1: Refer to Fig.2-32, the capacity of downstream units to L2 is 140×4=560, i.e. the gas pipe for L2 is Φ28.6, liquid pipe is Φ15.9.

### 2.4.4 Size of joint pipes for outdoor unit

Base on the following tables, select the diameters of the outdoor unit connective pipes. In case of the main accessory pipe large than the main pipe, take the large one for the selection.

Example: parallel connect with the three outdoor units 16+16+14 (the total capacity is 46HP), all indoor units total capacity is 1360, provided that the equivalent length of all pipes are ≥90m, according to the Table 2-14 the main pipe diameter are Φ41.3/Φ22.2; in according to all indoor unit capacity 1360, we could find out the master unit diameter is Φ44.5/Φ22.2 base on Table 2-12. Take the large one for the selection, we final confirm the main pipe diameter is Φ44.5/Φ22.2.

Table.2-13 Size of joint pipes for 410A outdoor unit

Model	When the equivalent length of all liquid pipes < 90m, the size of main pipe(mm)		
	Gas side	Liquid side	The 1st branching pipe
8HP	Φ22.2	Φ12.7	SQZHN-02(i)
10HP	Φ25.4	Φ12.7	SQZHN-02(i)
12HP	Φ28.6	Φ12.7	SQZHN-03(i)
14~16HP	Φ28.6	Φ15.9	SQZHN-03(i)
18~22HP	Φ31.8	Φ15.9	SQZHN-03(i)
24HP	Φ34.9	Φ15.9	SQZHN-04(i)
26~32HP	Φ34.9	Φ19.1	SQZHN-04(i)
34~48HP	Φ41.3	Φ19.1	SQZHN-05(i)
50~64HP	Φ44.5	Φ22.2	SQZHN-05(i)

Table.2-14 Size of joint pipes for 410A outdoor unit

Model	When the equivalent length of all liquid pipes ≥ 90m, the size of main pipe(mm)		
	Gas side	Liquid side	The 1st branching pipe
8HP	Φ25.4	Φ12.7	SQZHN-02(i)
10HP	Φ25.4	Φ12.7	SQZHN-02(i)
12HP	Φ28.6	Φ15.9	SQZHN-03(i)
14~16HP	Φ31.8	Φ15.9	SQZHN-03(i)
18~22HP	Φ31.8	Φ19.1	SQZHN-03(i)
24HP	Φ34.9	Φ19.1	SQZHN-04(i)
26~32HP	Φ38.1	Φ22.2	SQZHN-04(i)
34~48HP	Φ41.3	Φ22.2	SQZHN-05(i)
50~64HP	Φ44.5	Φ25.4	SQZHN-05(i)

### 2.4.5 Branch pipes for outdoor unit

Table.2-15

Model	Outdoor unit pipe connective opening dimension(mm)	
	Gas side	Liquid side
8HP, 10HP	Φ25.4	Φ12.7
12HP, 14HP, 16HP	Φ31.8	Φ15.9

### 2.4.6 Branch pipes for indoor unit

Base on Table 2-16 and Table 2-17 select the multi connecting pipes of outdoor unit. Before installation, please read the Outdoor Unit Branching Pipe Installation Manual carefully.

Table.2-16 Outdoor unit multi-connective pipe assembly (Illustration)

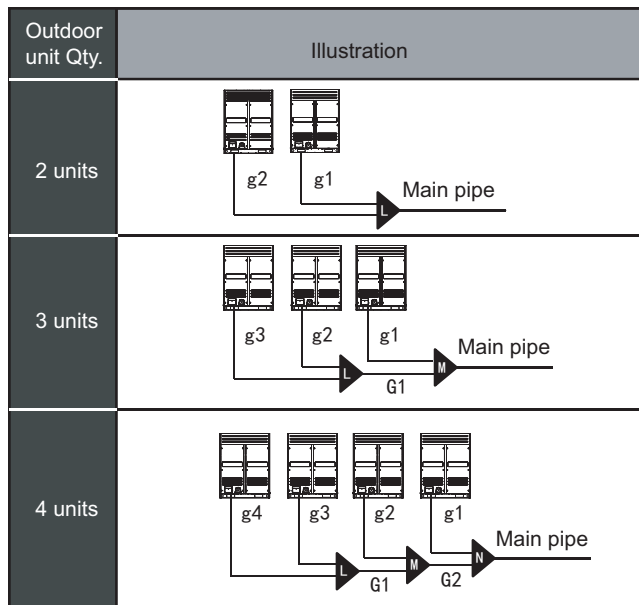


Table.2-17 Outdoor unit multi-connective pipe assembly

Outdoor unit Qty.	Outdoor unit connective pipe diameter	Parallel connect with the branching pipes	Main pipe
2 units	g1, g2: 8, 10HP: $\Phi 25.4/\Phi 12.7$ ; 12~16HP: $\Phi 31.8/\Phi 15.9$	L: SQZHW-02N1(i)	Refer to Table 2-13 or 2-14 for main pipe dimension
3 units	g1, g2, g3: 8, 10HP: $\Phi 25.4\Phi/12.7$ ; 12~16HP: $\Phi 31.8\Phi/15.9$ ; G1: $\Phi 38.1/\Phi 19.1$	L+M: SQZHW-03N1(i)	
4 units	g1, g2, g3, g4: 8, 10HP: $\Phi 25.4\Phi/12.7$ ; 12~16HP: $\Phi 31.8/\Phi 15.9$ ; G1: $\Phi 38.1/\Phi 19.1$ ; G2: $\Phi 41.3/\Phi 22.2$	L+M+N: SQZHW-04N1(i)	

Note: The pipe assemblies in above table is special for this model, must be purchased separately.

### 2.4.7 Example

- 1) Take (16+14+10) HP that composed by three modules as an example to clarify the pipe selection.
- 2) Take Fig.2-33 as an example. Provided that the equivalent length of all pipes in this system is larger than 90m.

Table.2-18

Unit: mm

Indoor unit capacity A( $\times 100W$ )	When branching pipe's length $\leq 10m$		When branching pipe's length $> 10m$	
	Gas side	Liquid side	Gas side	Liquid side
A $\leq 45$	$\Phi 12.7$	$\Phi 6.4$	$\Phi 15.9$	$\Phi 9.5$
A $\geq 56$	$\Phi 15.9$	$\Phi 9.5$	$\Phi 19.1$	$\Phi 12.7$

A The branching pipe at the inside of the unit.  
There are a~j branching pipes at the inside of the unit, the branching pipe diameter should be select as per Table 2-18.

B Main pipe at the inside the unit (Refer to Table 2-12)

- 1) The main pipe L3 with N1, N2 downstream indoor units that total capacity is  $140 \times 2 = 280$ , the pipe L3 diameter is  $\Phi 22.2/\Phi 12.7$ , thus select SQZHN-02(i) for the branching pipe C.
- 2) The main pipe L4 with N3, N4 downstream indoor units that total capacity is  $140 \times 2 = 280$ , the pipe L3 diameter is  $\Phi 22.2/\Phi 12.7$ , thus select SQZHN-02(i) for the branching pipe D.
- 3) The main pipe L2 with N1~N4 downstream indoor units that total capacity is  $140 \times 4 = 560$ , the pipe L2 diameter is  $\Phi 28.6/\Phi 15.9$ , thus select SQZHN-03(i) for the branching pipe B.
- 4) The main pipe L7 with N6, N7 downstream indoor units that total capacity is  $71 \times 2 = 142$ , the pipe L7 diameter is  $\Phi 19.1/\Phi 9.5$ , thus select SQZHN-01(i) for the branching pipe G.
- 5) The main pipe L6 with N5~N7 downstream indoor units that total capacity is  $140 + 71 \times 2 = 282$ , the pipe L6 diameter is  $\Phi 22.2/\Phi 12.7$ , thus select SQZHN-02(i) for the branching pipe F.
- 6) The main pipe L9 with N9, N10 downstream indoor units that total capacity is  $56 + 80 = 136$ , the pipe L9 diameter is  $\Phi 19.1/\Phi 9.5$ , thus select SQZHN-01(i) for the branching pipe I.

- 7) The main pipe L8 with N8~N10 downstream indoor units that total capacity is  $140 + 56 + 80 = 276$  the pipe L8 diameter is  $\Phi 22.2/\Phi 12.7$ , thus select SQZHN-02(i) for the branching pipe H.
- 8) The main pipe L5 with N5~N10 downstream indoor units that total capacity is  $140 \times 2 + 56 + 71 \times 2 + 80 = 558$ , the pipe L5 diameter is  $\Phi 28.6/\Phi 15.9$ , thus select SQZHN-03(i) for the branching pipe E.
- 9) The main pipe A with N1~N10 downstream indoor units that total capacity is  $140 \times 6 + 56 + 71 \times 2 + 80 = 1118$ , thus select SQZHN-05(i) for the branching pipe A.

C Main pipe (Refer to Table 2-12, Table 2-14):  
Main pipe L1 in the Fig.2-32, which upstream outdoor units total capacity is  $12 + 12 + 16 = 40$ , base on Table 2-14, the gas/liquid pipe diameter are  $\Phi 41.3/\Phi 22.2$ , total capacity of the downstream indoor unit is  $140 \times 6 + 56 + 71 \times 2 + 80 = 1118$ , base on Table 2-12, the gas/liquid pipe diameter are  $\Phi 41.3/\Phi 19.1$ , take the large one for your selection, final confirm the main pipe diameter is: gas/liquid pipe  $\Phi 41.3/\Phi 22.2$ .

D Parallel connect the outdoor units

- 1) The outdoor unit linked by Pipe g1 is 10HP, parallel connects with outdoor unit. the connective pipe diameter to be selected according to its connector size is  $\Phi 25.4/\Phi 12.7$ ;  
The outdoor unit linked by Pipe g2 is 14HP, parallel connects with outdoor unit. the connective pipe diameter to be selected according to its connector size is  $\Phi 31.8/\Phi 15.9$ ;  
The outdoor unit linked by Pipe g3 is 16HP, parallel connects with outdoor unit. the connective pipe diameter to be selected according to its connector size is  $\Phi 31.8/\Phi 15.9$ .
- 2) The upstream of G1 is the two parallel connected outdoor units, refer to Table 2-17 select the three parallel connected outdoor unit, the pipe diameter is  $\Phi 38.1/\Phi 19.1$ .
- 3) Parallel connect the three outdoor units, refer to Table 2-17 should select SQZHW-03N1(i) for outdoor unit connective pipes (L+M).

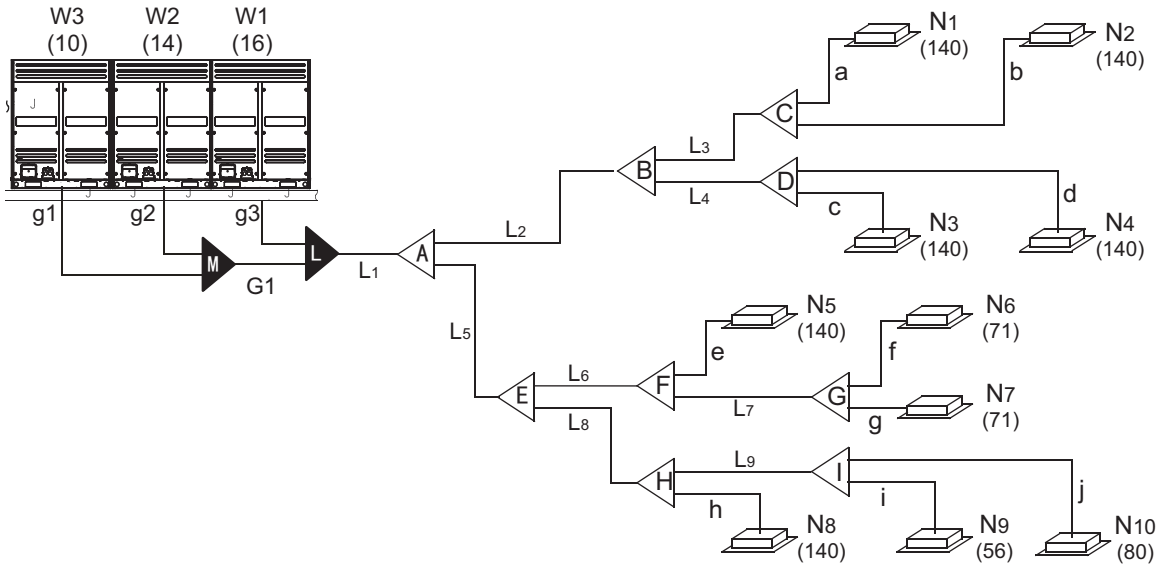


Fig.2-33

### 2.4.8 Remove dirt or water in the piping

- Make sure there is no any dirt or water before connecting the piping to the outdoor units.
- Wash the piping with high pressure nitrogen, never use refrigerant of the outdoor unit.

### 2.4.9 Gas tight test

- 1) Upon set up the indoor unit pipeline, please connect the Hi-pressure pipe with shut-off valve firstly.
- 2) Weld the pipe at the low pressure side to the meter connector.
- 3) Use the vacuum pump discharging air inside the liquid side shut-off valve and meter connector, until to the  $-1\text{kgf/cm}^2$ .
- 4) Close the vacuum pump, charge  $40\text{kgf/cm}^2$  nitrogen gas from the piston of shut-off valve and from the meter connector. Pressure inside should be maintained at there no less than 24 hrs.
- 5) Upon the airtightness test, do a good welding between float valve and pipe at the low pressure side.

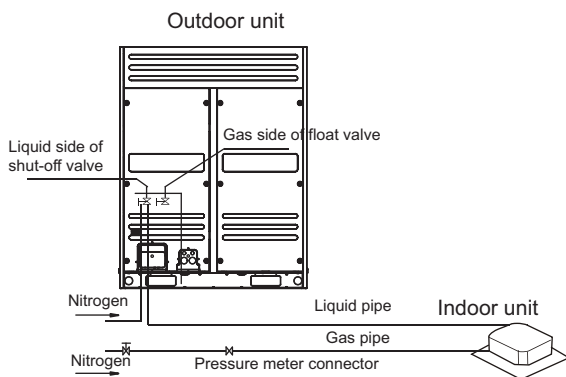


Fig.2-34



### CAUTION

- Pressurized nitrogen ( $3.9\text{MPa}$ ;  $40\text{kgf/cm}^2$ ) is used for airtightness test.
- It is not allow to bring pressure on the float valve directly. (See Fig. 5-4)
- It is not allow to use oxygen, combustible gas or toxic gas to conduct the airtightness test.
- When welding, please use wet cloth insulating the low pressure valve for protection.
- For avoid the equipment be damaged, the pressure maintainedtime should not last too long.

### 2.4.10 Vacuum with vacuum pump

- 1) Use the vacuum pump which vacuum level lower than  $-0.1\text{MPa}$  and the air discharge capacity above  $40\text{L/min}$ .
- 2) The outdoor unit is not necessary to vacuum, don't open the outdoor unit gas and liquid pipe shut-off valves.
- 3) Make sure the vacuum pump could result as  $-0.1\text{MPa}$  or below after 2 hrs or above operation. If the pump operated 3 hrs or above could not achieve to  $-0.1\text{MPa}$  or below, please check whether water mix or gas leak inside of the pipe.

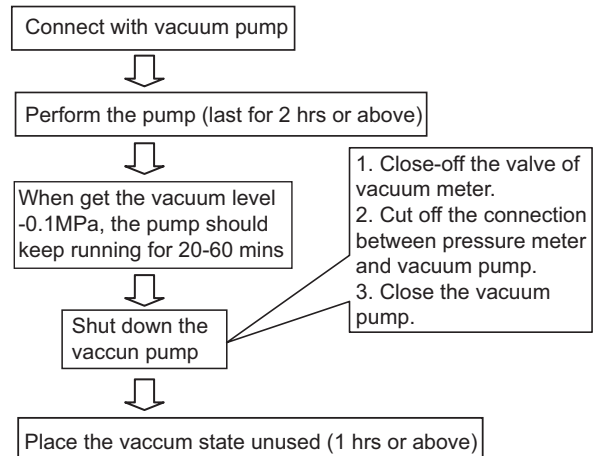


Fig.2-35



**CAUTION**

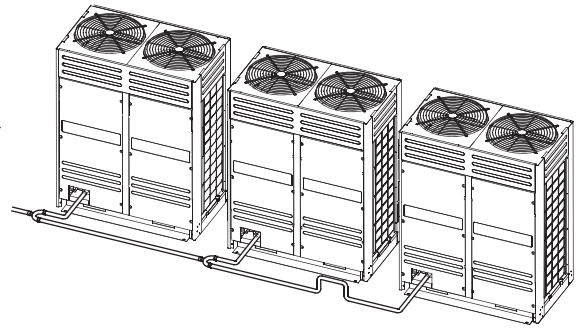
- Don't mix up the different refrigerants or abuse the tools and measurements which directly contact with refrigerants.
- Don't adopt refrigerant gas for air vacuuming.
- If vacuum level could not get to -0.1MPa, please check whether resulted by leakage and confirm the leakage site. If no leakage, please operate the vacuum pump again 1 or 2 hrs.

**2.4.11 Refrigerant amount to be added**

Calculate the added refrigerant according to the diameter and the length of the liquid side pipe of the outdoor/indoor unit connection. The refrigerant is R410A.

Table.2-19

Pipe size on liquid side	Refrigerant to be Added per meter
Φ6.4	0.023kg
Φ9.5	0.060kg
Φ12.7	0.120kg
Φ15.9	0.180kg
Φ19.1	0.270kg
Φ22.2	0.380kg
Φ25.4	0.520kg
Φ28.6	0.680kg

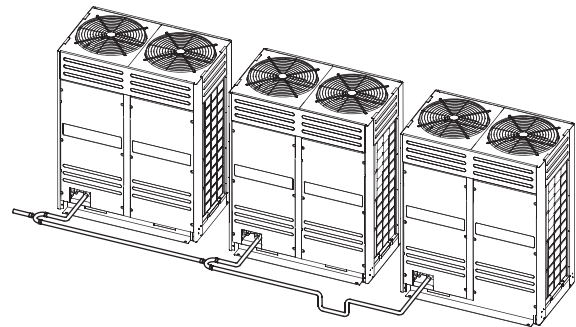


✓ Correct way

Fig.2-37

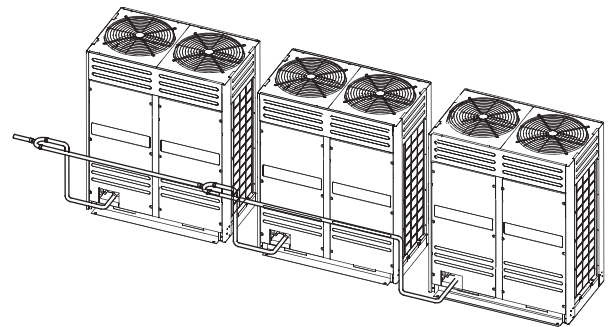
**2.4.12 The Installation key points of connective pipes between outdoor units**

- 1) Connect the pipes between outdoor units, the pipes should place horizontally (Fig.2-36, Fig.2-37), it is not allow the concave at junction site (Refer to Fig.2-38).
- 2) All connective pipes between the outdoor units are not allowed to over than the height of every outlets of the pipes (Refer to Fig.2-39).



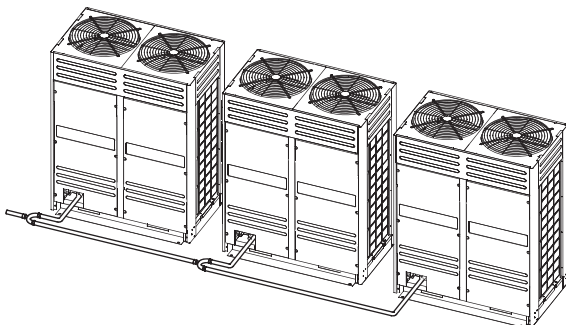
× Wrong way

Fig.2-38



× Wrong way

Fig.2-39



✓ Correct way

Fig.2-36

- 3) The branching pipe must be installed horizontally, error angle of it should not large than 10°. Otherwise, malfunction will be caused.

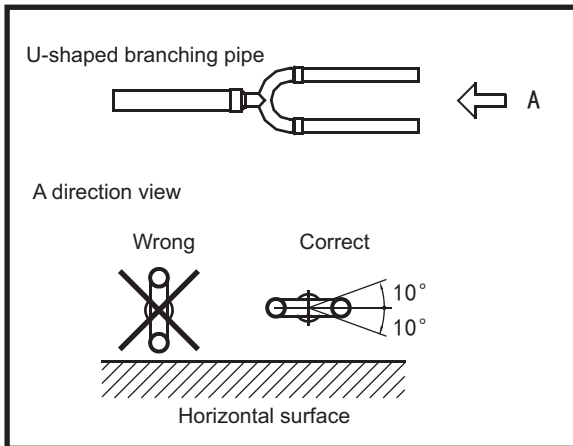


Fig.2-40

- 4) For avoid oil accumulate at the outdoor unit, please install the branching pipes properly.

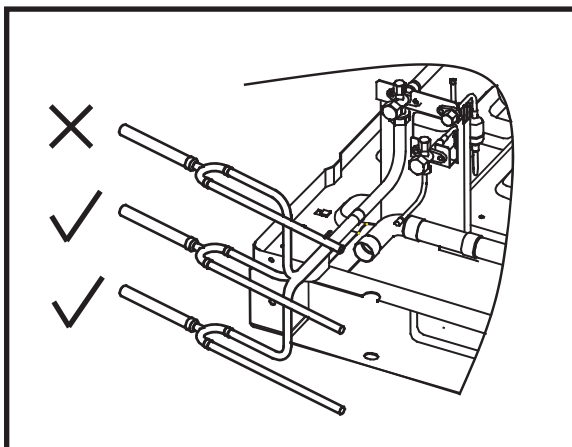


Fig.241

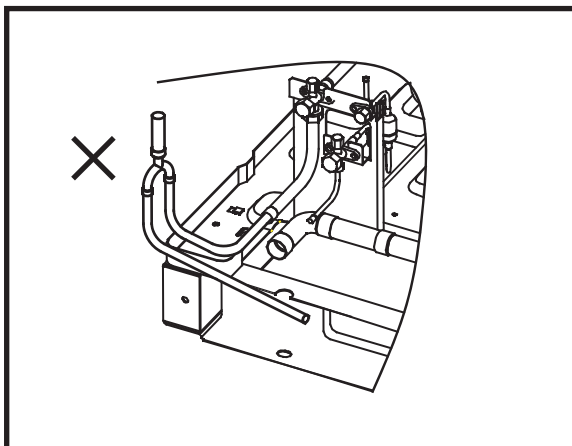


Fig.2-42

## 2.5 ELECTRIC WIRING

### 2.5.1 Sw1 query instructions

Use application of the SW1 spot check

Table.2-20

No.	Display content (Normal display)	Note
1	Outdoor unit address	0, 1, 2, 3
2	Outdoor unit capacity	8, 10, 12, 14, 16
3	Modular outdoor unit qty.	Available for master unit
4	Outdoor unit total capacity	Capacity requirement
5	Indoor unit total capacity requirement	Available for master unit
6	The corrected total capacity of master unit	Available for master unit
7	Operation mode	0, 1, 2, 3, 4
8	The actual operation capacity of this outdoor unit	Capacity requirement
9	Fan status	0, 1, 2, 3, 4 5, 6, 7, 8, 9
10	T2B/T2 average temp.	Actual value
11	T3 pipe temp.	Actual value
12	T4 ambient temp.	Actual value
13	Inverter air discharge temp.	Actual value
14	Fixed frequency 1 air discharge temp.	Actual value
15	Fixed frequency 2 air discharge temp.	Actual value
16	Inverter current	Actual value
17	Fixed frequency 1 current	Actual value
18	Fixed frequency 2 current	Actual value
19	TXV opening angle	Actual value × 8
20	Air discharge pressure	Actual value × 0.1MPa
21	The limitation of Indoor unit proformed mode	0,1,2,3,4
22	Indoor unit qty	Actual value
23	The last time error orprotective code	Without protection or error displays as 00
24	— —	Spot inspection end

Normal display:

When in standby, it displays the indoor unit qty. When receive the capacity requirement, it will display the compressor rotation frequency (indoor unit qty. is the unit qty. that could communicate with outdoor unit)

Operation mode: 0—OFF; 1—Air supply; 2—Cooling; 3—Heating(Cooling only type without); 4—Constraint cooling

Rotation speed: 0—fan stop; 1~9 rotation speed turn down sequentially, 9 is the maximum speed

The limitation of Indoor unit proformed mode : 0—Heating Priority Mode; 1—Cooling Priority Mode; 2—Priority Mode; 3—Only Respond The Heating Mode; 4—Only Respond The Cooling Mode.

PMV opening angle: pulse count=display value×8; ENC1: Outdoor unit address setting switch; ENC2: Outdoor unit capacity setting switch; ECN3: Network address setting switch. SW1: spot check button; SW2: forced cooling button; 8, 10, 12HP none-fixed frequency 2 air discharge temp.; fixed frequency 2 current. (Includes the connective wire that through the CT2 mutual-current inductor connect with HEAT 2)



### 2.5.2 Terminal base function

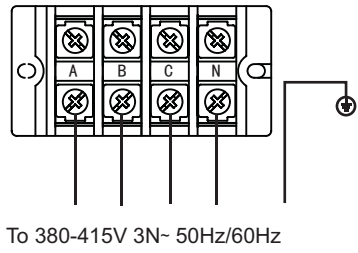


Fig.2-43

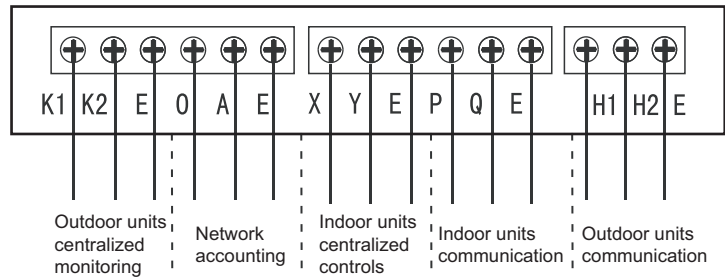


Fig.2-44

### 2.5.3 Explanation of main board

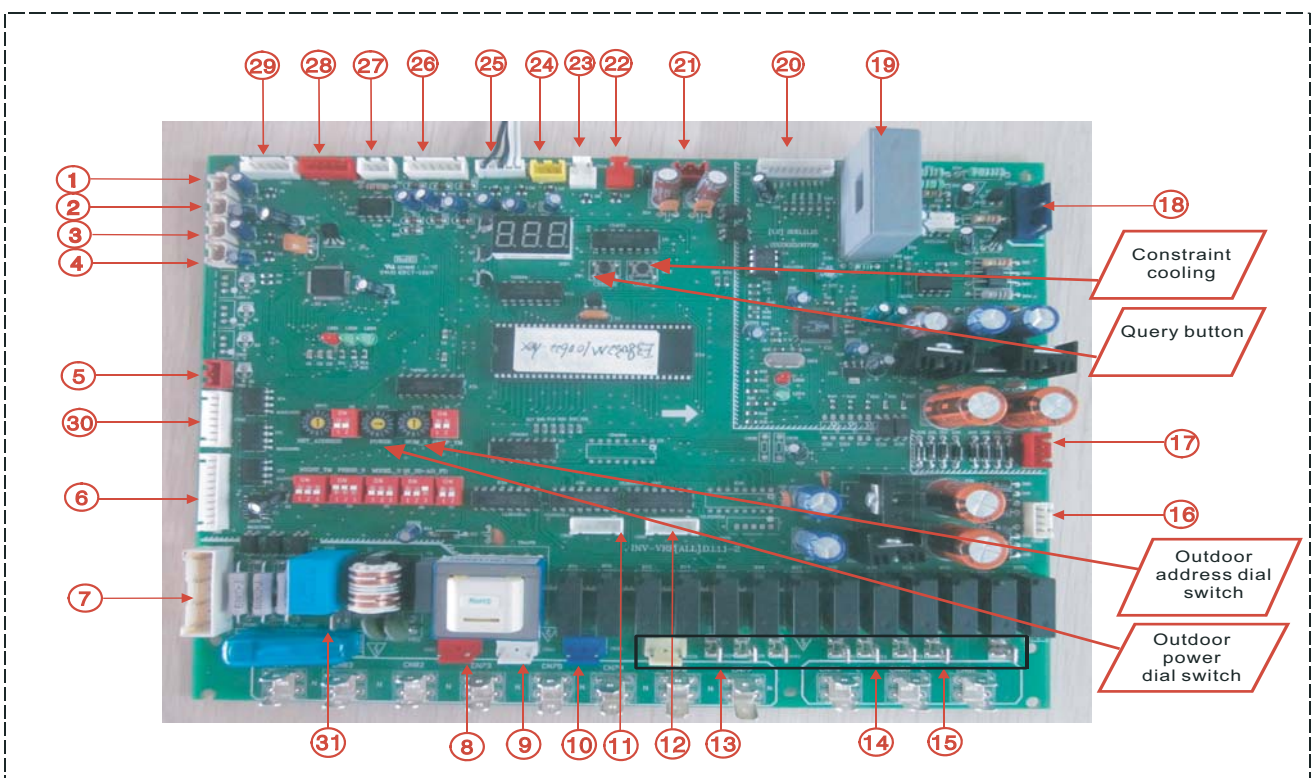
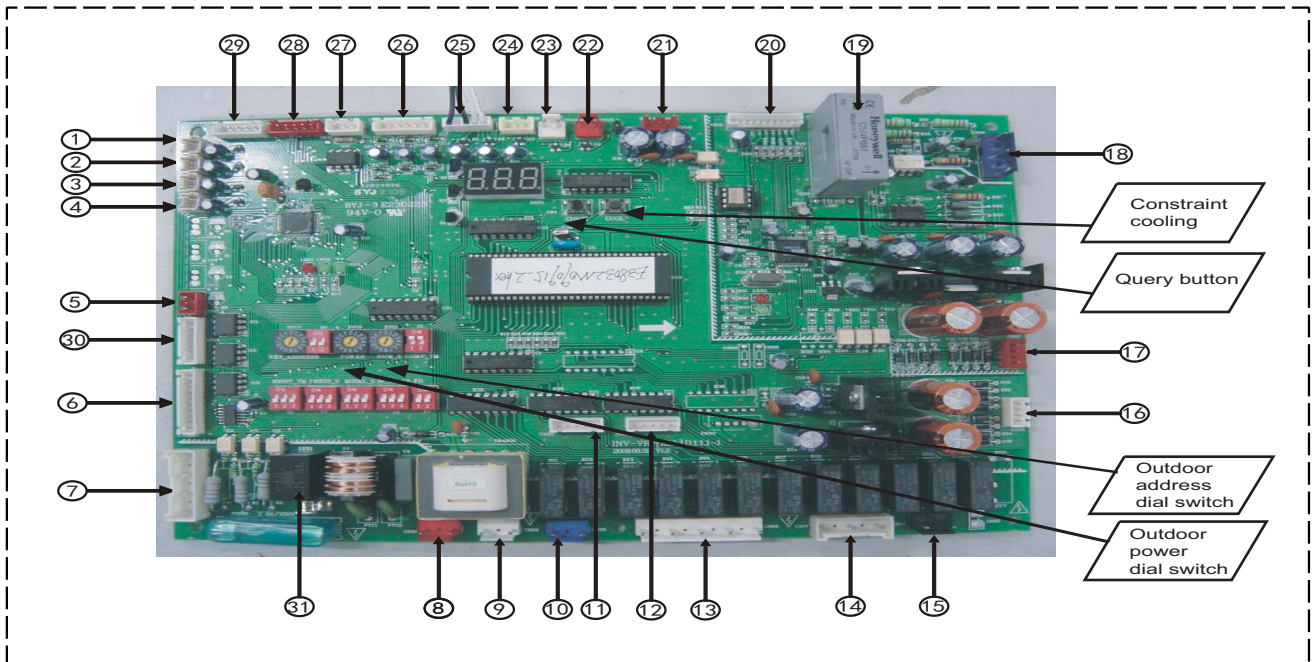


Fig.2-45

■ Explanation of main board

Table.2-21

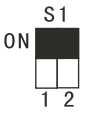
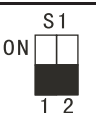
No.	Content
1	Reserve
2	Air discharge temp. sensed port at the No.2 fixed frequency compressor
3	Air discharge temp. sensed port at the No.1 fixed frequency compressor
4	Air discharge temp. sensed port at the inverter compressor
5	Power supply port in the Mid-adapted panel
6	Communication between indoor and outdoor units, indoor unit network, outdoor unit network and terminal of network accounting
7	Phase inspection port
8	Power input of the No.1 transformer
9	Power input of the No.2 transformer
10	Loading output terminal
11	NO.2 EXV activation port
12	NO.1 EXV activation port
13	Loading output terminal
14	Loading output terminal
15	Loading output terminal
16	Power output of the No.1 transformer
17	Power output of the No.2 transformer
18	Port for inverter module voltage inspection
19	Mutual inductor for DC main lead current inspection
20	Activation port of inverter module
21	Power supply connected port of the main control panel
22	ON/OFF signal input port for system low pressure inspection
23	ON/OFF signal input port for system Hi-pressure inspection
24	Input port for system pressure inspection
25	Inspection port for outdoor ambient temp. and condensator coil temp.
26	Current inspection port of the inverter, No.1 and No.2 fixed frequency compressors
27	Communication ports among outdoor units
28	Control port of DC fan 1
29	Control port of DC fan 2
30	Reserve
31	C phase power supply

2.5.4 Dial codes definition

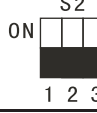

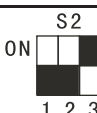
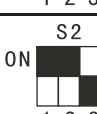


Fig.2-46

S1 definition

ON 	Starting time is set about 3 minutes
ON 	Starting time is set about 12 minutes (Default the Factory Set)

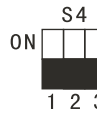
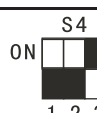
S2 definition

ON 	Night time selection is 6h/10h (Default the Factory Set)
ON 	Night time selection is 8h/10h
ON 	Night time selection is 6h/12h
ON 	Night time selection is 8h/8h

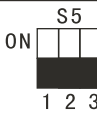
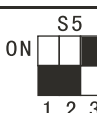
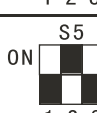
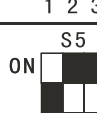

S3 definition

ON 	Reserve
--	---------

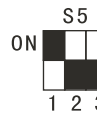
S4 definition

ON 	Static pressure mode is 0 MPa (Default the Factory Set)
ON 	Static pressure mode is high pressure

S5 definition(For cooling&heating type)

ON 	Heating priority mode (Default the Factory Set)
ON 	Cooling priority mode
ON 	Priority mode
ON 	Only Respond the heating mode
ON 	Only Respond the cooling mode

S5 definition(For cooling only type)

ON 	Only Respond the cooling mode(Default the Factory Set)
--	--

### S6 definition

	Night noise control mode and automatic search address.
	Night noise control mode and nonautomatic search address. (The communication way of the original digital indoor unit) (Default the Factory Set)
	Clean the indoor unit addresses.
	Non-night noise control mode and automatic search address.
	Non-night noise control mode and nonautomatic search address. (The communication way of the original digital indoor unit)

### S7 definition

	Reserve
--	---------

## 2.5.5 Electric wiring system and installation



### CAUTION

- Please select power supply for indoor unit and outdoor unit separately.
- The power supply should have specified branch circuit with leakage protector and manual switch.
- The power supply, leakage protector and manual of all the indoor units connecting to the same outdoor unit should be universal. (Please set all the indoor unit power supply of one system into the same circuit. It should turn on or shut down the unit at the same time, otherwise, the service life would affect seriously, even the unit may not turn on.)
- Please put the connective wiring system between indoor unit and outdoor unit with refrigerant piping system together.
- It is suggested to use 3-core shielded wire as signal wire between indoor and outdoor units, multi-core wire is unavailable.
- Please comply with relevant National Electric Standard.
- Power wiring should be done by professional electrician.

### 2.5.5.1 Outdoor unit power wiring

- Separate Power Supply (without power facility) (See Table.6-3)

Table.2-21

Item Model	Power supply	Min. Power wire diameter (mm <sup>2</sup> ) Wiring of metal and synthetic resin		Manual switch (A)		Leakage protector
		Size (Continuous length of pipe m)	Grounding wire	Capacity	Fuse	
8、10、12HP	380-415V 3N~50Hz	4×10 mm <sup>2</sup> (<20 m) 4×16 mm <sup>2</sup> (<50 m)	1×10 mm <sup>2</sup>	30	25	100mA 0.1sec or less
14、16HP	/60Hz	4×16 mm <sup>2</sup> (<20 m) 4×25 mm <sup>2</sup> (<50 m)	1×16 mm <sup>2</sup>	40	35	



### NOTE

- Select power cord for these five models separately according to relevant standard. 8HP, 10HP, 12HP, 14HP, 16HP.
- The wiring diameter and the length in the table indicate the condition that the voltage dropping range is within 2%. If the length exceeds the above figure, please select the wire diameter according to relevant standard.

- With power facilities

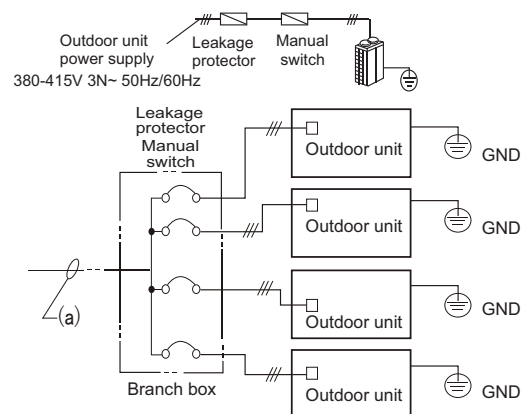


Fig.2-47

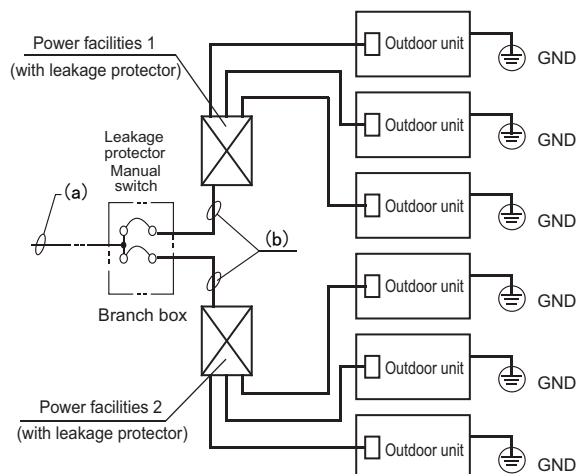


Fig.2-48



- Select the wire diameter  
Power wiring refer to the main wire (a) connecting to branch box and the wiring (b) between branch box and power facilities. Please select the wire diameter according to the following requirement.
- Diameter of main wire (a)  
Depends on the total horsepower of outdoor unit and following table.  
E.g In system:(8Hp×1unit+8Hp×1unit+10Hp×1unit)  
Total Hp=26Hp→(Table.6-4)→size of wire=35mm<sup>2</sup>(within 50m)
- Wiring(b):between branch box and power equipment.  
Depends on the number of combined outdoor unit. If fewer than 5, the diameter is the same as that of main wire (a); if more than 6, there will be 2 electric control boxes, and the diameter of wiring depends on the total horsepower of outdoor units connecting to each electric control box and following table.
- Select wire diameter (≥) (table.6-4) (unit :mm<sup>2</sup>)

Table.2-22

Total HP	<20m	<50m
8	10	16
10	10	16
12	10	16
14	16	25
16	16	25
18	16	25
20	16	25
22	16	25
24	25	35
26	25	35
28	25	35
30	35	50
32	35	50
34	35	50
36	35	50
38	35	50
40	35	50
42	50	70
44	50	70
46	50	70
48	50	70
50	70	95
52	70	95
54	70	95
56	70	95
58	70	95
60	70	95
62	70	95
64	70	95

- Select the capacity of manual switch and fuse of the branch box.
- See following table when without power facilities, depends on the outdoor unit it connecting to.
- See table.6-5 below when there is power facility, depends on the total horsepower.

Table.2-23 Total horsepower, capacity of manual switch and fuse

Total HP	Manual switch (A)	Fuse(A)
10~14	40	35
15~18	63	45
19~28	80	65
29~36	80	75
37~47	120	100
48~50	150	120

- Indoor power supply

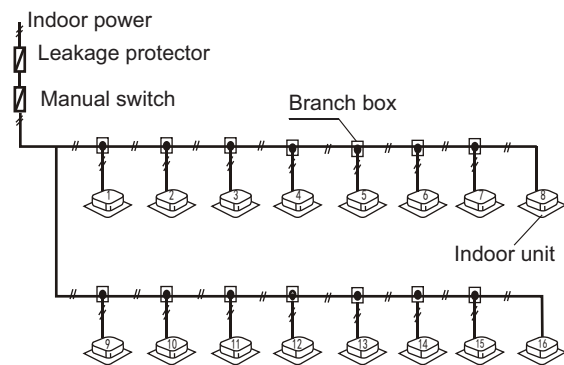


Fig.2-49



**CAUTION**

- Set refrigerant piping system, signal wires between indoor-indoor unit, and that between outdoor-outdoor unit into one system.
- Power must unified supply to all indoor units in the same system.
- Please do not put the signal wire and power wire in the same wire tube; keep distance between the two tubes. (Current capacity of power supply: less than 10A--300mm, less than 50A--500mm.)
- Make sure to set address of outdoor unit in case of parallel multi-outdoor units.

## 2.5.6 Control system and Installation

- The control line should be shielded wire. Using other wiring shall create signal interference, thus leading to error operation.
- The shielded nets at the two sides of shielded wires are either grounded to the earth, or connected with each other and jointed to the sheet metal along to the earth.
- Control wire could not be bound together with refrigerant pipeline and power wire. When power wire and control wire is distributed in parallel form, keep gap between them above 300mm so as to preventing signal interference.
- Control wire could not form closed loop.
- Control wire has polarity, so be careful when connecting.

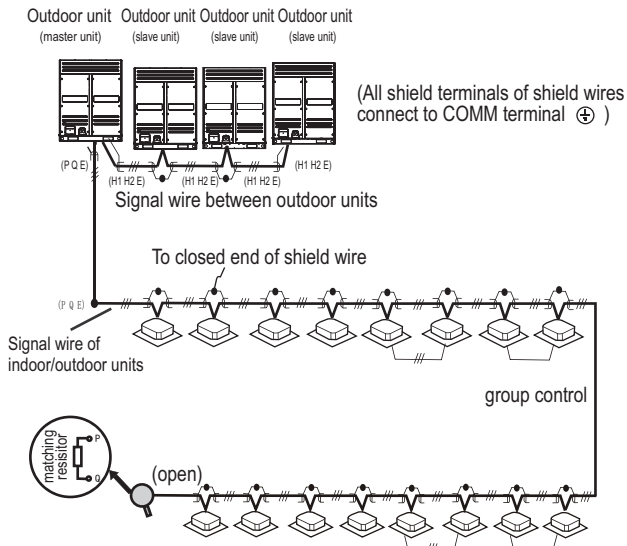


### NOTE

The shield net should be grounded at the wiring terminal of outdoor unit. The inlet and outlet wire net of indoor communication wire should be connected directly and could not be grounded, and form open circuit at the shield net of final indoor unit.

## 2.5.7 Signal wire of indoor/outdoor units

- Signal wire of indoor/outdoor unit adopts 3-core shielded wire ( $\geq 0.75\text{mm}^2$ ) which has polarity, please connect it correctly.



The indoor unit at the terminal of communication system should parallel connect a impedance between port P and port Q.

Fig.2-50

## 2.5.8 Example for power wire connection

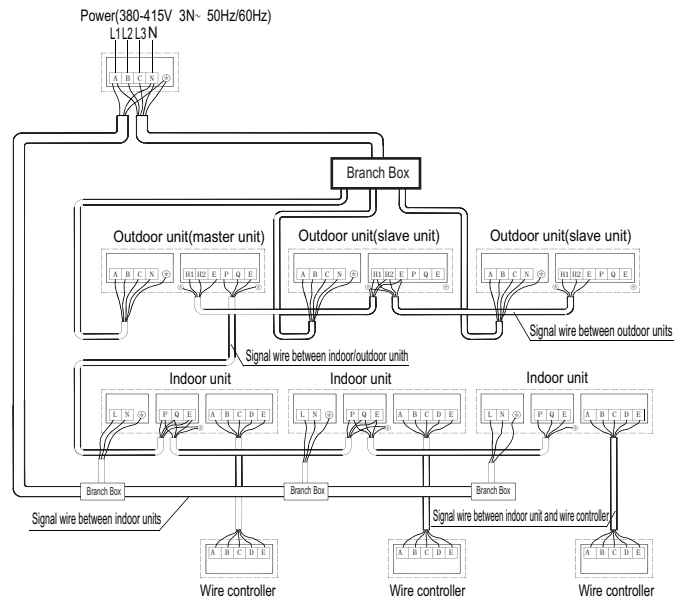


Fig.2-51

## 2.6 TRIAL RUN

### 2.6.1 Inspection and confirmation before commissioning

- Check and confirm that refrigeration pipe line and communication wire with indoor and outdoor unit have been connected to the same refrigeration system. Otherwise, operation troubles shall happen.
- Power voltage is within  $\pm 10\%$  of rated voltage.
- Check and confirm that the power wire and control wire are correctly connected.
- Check whether wire controller is properly connected.
- Before powering on, confirm there is no short circuit to each line.
- Check whether all units have passed nitrogen pressure-keeping test for 24 hours with R410A:  $40\text{kg}/\text{cm}^2$ .
- Confirm whether the system to debugging has been carried out vacuum drying and packed with refrigeration as required.

### 2.6.2 Preparation before debugging

- Calculating the additional refrigerant quantity for each set of unit according to the actual length of liquid pipe.
- Keep required refrigerant ready.
- Keep system plan, system piping diagram and control wiring diagram ready.
- Record the setting address code on the system plan.
- Turn on power switches outdoor unit in advance, and keep connected for above 12 hours so that heater heating up refrigerant oil in compressor.

- Turn on air pipe stop valve, liquid pipe stop valve, oil balance valve and air balance valve totally. If the above valves do not be turned on totally, the unit should be damaged.
- Check whether the power phase sequence of outdoor unit is correct.
- All dial switch to indoor and outdoor unit have been set according to the Technical Requirement of Product.

### 2.6.3 Fill the name of connected system

To clearly identify the connected systems between two or more indoor units and outdoor unit, select names for every system and record them on the nameplate on the outdoor electric control box cover.

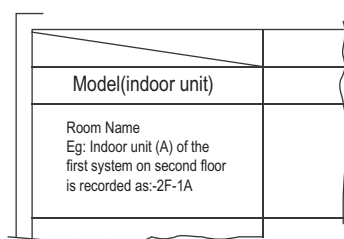


Fig.2-52

$$\frac{A \text{ [kg]}}{B \text{ [m}^3]} \leq \text{Critical thickness: } 0.3 \text{ [kg/m}^3]$$

- Countermeasure against overhigh thickness
  - Install mechanical ventilator to reduce the refrigerant thickness under critical level. (ventilate regularly)
  - Install leakage detector alarming device related to mechanical ventilator if you can not regularly ventilate.

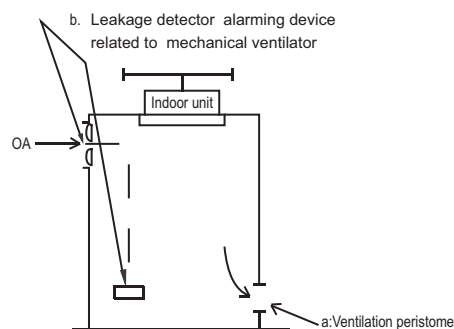


Fig.2-54

### 2.6.4 Caution on refrigerant leakage

- This air conditioner adopts R410A as refrigerant, which is safe and noncombustible.
- The room for air conditioner should be big enough that refrigerant leakage can not reach the critical thickness. Besides this, you can take some action on time.
- Critical thickness-----the max thickness of Freon without any harm to person. R410A critical thickness:0.3 [ kg/m<sup>3</sup>]

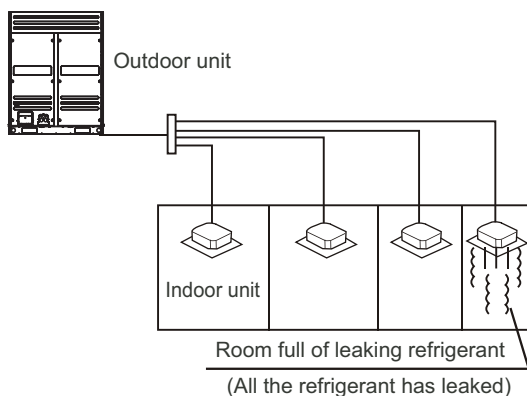


Fig.2-53

### 2.6.5 Turn over to customer

Be sure to deliver the Installation Manual of the indoor unit, and the outdoor unit to the user.

- Calculate the critical thickness through following steps, and take necessary actions.
  - Calculate the sum of the charge volume (A[kg])  
Total refrigerant volume=refrigerant volume when delivered(nameplate)+superaddition
  - Calculate the indoor cubage (B[m<sup>3</sup>]) (as the minimum cubage)
  - Calculate the refrigerant thickness.

## 2.7 CUSTOMER DETAILS

Branch Address : .....  
.....  
.....

Telephone : .....

Person to be contacted : .....

Dealer address : .....  
.....  
.....

Telephone : .....

Person to be contacted : .....  
.....

Signature of the Dealer with Seal.

In all correspondence/communication state your name, address, the serial number of your air conditioning unit, date of purchase and dealer's name (include address), location of unit and description of problem, for prompt and immediate attention

Name of Customer : .....

Address : .....  
.....  
.....

Sr.No. of the Unit : .....

Sr.No. of the Compressor : ..... Date of purchase:.....

Invoice No : .....

