



U-MATCH Air Conditioners
Service Manual
(T1/R410a/50Hz)

GREE ELECTRIC APPLIANCES INC. OF ZHUHAI

CONTENTS

PRODUCT	2
1 MODELS LIST	2
1.1 Outdoor Unit	2
1.2 Indoor Unit.....	3
2 NOMENCLATURE	4
3 FUNCTION	5
4 PRODUCT DATA	6
4.1 Product Data at Rated Condition.....	6
4.2 Operation Range.....	18
4.3 Electrical Data.....	19
5 PIPING DIAGRAM	20
CONTROL	22
1 OPERATION FLOWCHART	22
1.1 Cooling/Dry Operation.....	22
1.2 Heating Operation	23
2 MAIN LOGIC	24
2.1 Cooling.....	24
2.2 Dry Mode	25
2.3 Heating Mode.....	26
2.4 Defrosting.....	27
2.5 Fan Mode	28
3 WIRELESS REMOTE CONTROLLER	29
3.1 Operation View	29
3.2 Display View	31
4 WIRED REMOTE CONTROLLER	32
4.1 Operation View	32
4.2 Display View	34
4.3 Dimension	35
4.4 Installation.....	35
5 CENTRALIZED CONTROLLER	37
5.1 Centralized Controller-not with week timer.....	37
5.2 Centralized Controller-week timer	38
5.3 Field Setting	42
5.4 Control Wiring Design	43
INSTALLATION	45
1 INDOOR UNIT INSTALLATION	45
1.1 Installation of Duct Type.....	45
1.2 Installation of Ceiling Type.....	54
1.3 Installation of Cassette Type	59
2 OUTDOOR UNIT INSTALLATION	70
2.1 Before Installation.....	70

2.2 Installation Site.....	70
2.3 Caution for Installation	70
2.4 Dimension Data.....	71
2.5 Installation Clearance Data	72
3 REFRIGERATION PIPING WORK.....	73
3.1 Refrigeration Piping Work Procedures.....	73
3.2 Caution in Connecting Pipes	76
3.3 Specification of Connection Pipe.....	77
4 ELECTRIC WIRING WORK.....	78
4.1 Wiring Principle	78
4.2 Electric Wiring Design.....	82
4.3 Specification of Power Supply Wire and Air Switch	85
MAINTENANCE.....	88
1 TROUBLE TABLE.....	88
2 FLOW CHART OF TROUBLESHOOTING.....	92
3 WIRING DIAGRAM.....	102
3.1 Wiring Diagram-Outdoor Units	102
3.2 Wiring Diagram-Indoor units.....	110
4 DISASSEMBLY AND ASSEMBLY PROCEDURE OF MAIN PARTS.....	112
4.1 Outdoor Unit	112
4.2 Indoor Unit.....	115
5 EXPLODED VIEWS AND PART LIST.....	159
5.1 Outdoor Unit	159
5.2 Indoor Unit.....	175

PRODUCT

PRODUCT

1 MODELS LIST

1.1 Outdoor Unit

Model	Nominal Capacity Cooling/Heating (Btu/h)	Ref.	Power Supply	Appearance
GUHN09NK3AO	8870/9720	R410a	220-240~,1,50	
GUHN12NK3AO	11940/12283	R410a	220-240~,1,50	
GUHN18NK3AO	17060/19448	R410a	220-240~,1,50	
GUHN24NK3AO	23884/27296	R410a	220-240~,1,50	
GUHN36NK3AO	33437/37532	R410a	220-240~,1,50	
GUHN36NM3AO	34120/37532	R410a	380-415~,3,50	
GUHN42NM3AO	40944/47768	R410a	380-415~,3,50	
GUHN48NM3AO	47768/52886	R410a	380-415~,3,50	
GUHN60NM3AO	54592/63122	R410a	380-415~,3,50	

Note: 1Ton = 12000Btu/h = 3.517kW

1.2 Indoor Unit

Type	Model	Nominal Capacity Cooling/Heating (Btu/h)	Ref.	Power Supply	Appearance
Duct Type	GFH09K3BI	8870/9720	R410a	220-240~ 1Ph 50Hz	
	GFH12K3BI	11940/12283			
	GFH18K3BI	17060/19448			
	GFH24K3BI	23880/27300			
	GFH36K3BI	33437/37500			
	GFH42K3BI	42000/48000			
	GFH48K3BI	48000/53000			
GFH60K3BI	60000/63120				
Floor- Ceiling Type	GTH09K3BI	8870/9720	R410a	220-240~ 1Ph 50Hz	
	GTH12K3BI	11940/12283			
	GTH18K3BI	17060/19448			
	GTH24K3BI	23880/27300			
	GTH36K3BI	33437/36781			
	GTH42K3BI	42000/48000			
	GTH48K3BI	48000/53000			
Cassette Type	GKH12K3BI	11940/12283	R410a	220-240~ 1Ph 50Hz	
	GKH18K3BI	17060/19448			
	GKH24K3BI	23201/25590			
	GKH36K3BI	36000/37500			
	GKH42K3BI	42000/48000			
	GKH48K3BI	48000/53000			

Note: 1Ton = 12000Btu/h = 3.517kW

NOTES:

The universal outdoor units means that the customer can choose any of three kind of indoor unit to match the outdoor unit without any change with it.

2 NOMENCLATURE

G U H N 09 N M 3 A O
 1 2 3 4 5 6 7 8 9 10

NO.	Description	Options
1	Gree Electric Appliances Inc	Capital Letter :G
2	Unit Type	U=Match Outdoor Unit F=Duct Type K=Cassette Type T= Ceiling Type
3	Product Type	C=Cool Only H=Heat Pump without Aux Electric Heaters
4	Power Supply Code	N=Constant Frequency D=DC Inverter A=AC Inverter
5	Nominal Cooling Capacity	Nominal Cooling Capacity =Number×1000Btu/h
6	Climate Type	N=Climate T1 Condition T= Climate T3 Condition
7	Power Supply Code	K=1Ph 220~240V 50HZ M=3Ph 380~415V 50HZ
8	Refrigerant	1 =R22 2=R407C 3=R410A
9	Design Code	Design Code:A,B,C,D.....
10	Unit Code for Condensing Unit or Indoor Unit	O=Outdoor I=Indoor Unit

3 FUNCTION

Function	Description
Memory function	when unit restart after power off, it will run on former status, the mode and parameter are kept the same
Remote control function	wireless controller and remote controller can be opted, and the maximum control distance of remote controller is 10m.
Timing function	it can timing ON/ OFF separately, meanwhile, it can also can timing on circularly
Self-diagnosis with alarm function	once unit has malfunction, the malfunction code will be indicated and alarm ring immediately
Sleep function	it can self control for saving energy in energy saving mode.
Automatic function	the fan of indoor unit can adjust fan speed automatically based on actual demand when cooling or heating under automatic mode
Cool air proof function	the fan starts only when the temperature of indoor unit heat exchanger is higher than indoor temperature under heating mode
Weekly Time	Centralized Control and Week Timer Functions: The centralized controller and the weekly timer are integrated in the same wire controller. The system has both the centralized control and the week timing functions. Up to 16 sets of units can be controlled simultaneously by the centralized controller (weekly timer). The weekly timer has the function of invalidating the lower unit. The weekly timing function is able to realized four timing ON/OFF periods for any unit every day, so as to achieve fully automatic operation. No timing control can be set for holidays.
High/low pressure protection	when suction pressure is too low or discharge pressure is too high, compressor will stop and unit display malfunction code
Overload protection	compressor has its own overheat protection, once the temperature of compressor is higher than allowable level, compressor will stop and only when temperature recovery, compressor restart
Over current protection	once the current of compressor is higher that normal level, compressor will stop and unit display malfunction code
Discharge high temperature protection	once the discharge temperature of compressor is higher than allowable value, compressor will stop and unit display malfunction code
Reverse (open) phase protection	once the phase sequence of power supply is incongruent or the phase is absent, unit can't work and display malfunction code
Anti-high temperature protection	once the heat exchanger temperature of indoor unit is too high, compressor stop and unit display malfunction code.
Timing ON/OFF display	display and timing turn ON/OFF time
Fan speed display	display the speed (high、 medium、 low) of fan
Function model display	cooling mode、 dehumidifying mode、 heating mode、 fan mode
Testing display	display testing mode
Temperature display	display room temperature and set temperature

4 PRODUCT DATA

4.1 Product Data at Rated Condition

4.1.1 Duct Type

Model	Indoor unit		GFH09K3BI	GFH12K3BI	GFH18K3BI
	Outdoor unit		GUHN09NK3AO	GUHN12NK3AO	GUHN18NK3AO
Nominal Capacity	Cooling	kW	2.6	3.5	5.0
		Btu/h	8870	11940	17060
	Heating	kW	2.85	3.6	5.7
		Btu/h	9720	12283	19448
Power Input	Cooling	kW	1.35	1.2	2.1
	Heating	kW	1.4	1.1	1.8
EER/COP		W/W	2.6/2.94	2.92/3.55	2.38/3.22
Indoor Unit			GFH09K3BI	GFH12K3BI	GFH18K3BI
Power Supply		—	220-240V~/1 Ph/50HZ		
Heat Exchange		—	Cross Fin Coil		
Fan	Type	—	Centrifugal fan		
	Drive	—	Direct Driver		
	Motor Output	kW	0.02×2	0.02×2	0.07×2
	Air Flow	m ³ /h	550	600	840
	Ext. Static Pressure	Pa	25	25	40
Sound Pressure Level (H/M/L)		dB(A)	37 / 36 / 34	40/38/36	42/40/38
Air Filter		—	Standard washable synthetic		
Drain Piping		mm	φ20×1.2	φ20×1.2	φ30×1.5
Dimensions (H×W×D) (Outline/Package)		mm	220×913×680/ 258×995×750	220×913×680/ 258×995×750	266×1012×736 308×1120×795
Weight (Net/Gross)		kg	27/32	27/32	36/39
Outdoor Unit			GUHN09NK3AO	GUHN12NK3AO	GUHN18NK3AO
Power Supply		—	220-240V~/1Ph/50HZ		
Heat Exchange		—	Cross Fin Coil		
Fan	Type	—	Axial fan		
	Motor Output	kW	0.03	0.03	0.03
	Fan Motor Speed	rpm	850		
Compressor	Type	—	ROTARY		
	Motor Output	kW	0.922	1.185	1.9
Refrigerant	Type	—	R410A		
	Control	—	Capillary Tube		
	Charge	kg	1.1	1.0	1.5
Dimensions (H×W×D) (Outline/Package)		mm	540×848×320/ 590×878×360	540×848×320/ 590×878×360	540×848×320/ 590×878×360
Weight (Net/Gross)		kg	32/37	32/37	40/45
Piping	Liquid	mm	6.35	6.35	6.35

Connections	Gas	mm	9.52	12.7	12.7
	Max. Length	m	20	20	20
	Max. Height Difference	m	15	15	15

Continued 1

Model	Indoor unit		GFH24K3BI	GFH36K3BI	GFH36K3BI
	Outdoor unit		GUHN24NK3AO	GUHN36NM3AO	GUHN36NK3AO
Nominal Capacity	Cooling	kW	7.0	9.8	10
		Btu/h	23880	33437	36000
	Heating	kW	8.0	11	11
		Btu/h	27300	37500	37500
Power Input	Cooling	kW	2.66	4.0	4.0
	Heating	kW	2.51	3.5	3.5
EER/COP		W/W	2.63/3.19	2.5/3.14	2.5/3.14
Indoor Unit			GFH24K3BI	GFH36K3BI	GFH36K3BI
Power Supply		—	220-240V~/1 Ph/50HZ		
Heat Exchange		—	Cross Fin Coil		
Fan	Type	—	Centrifugal fan		
	Drive	—	Direct Driver		
	Motor Output	kW	0.15×2	0.5×2	0.5×2
	Air Flow	m ³ /h	1400	2000	2000
	Ext. Static Pressure	Pa	80	150	150
Sound Pressure Level (H/M/L)		dB(A)	44 / 42 / 40	50 / 48 / 46	50 / 48 / 46
Air Filter		—	Standard washable synthetic		
Drain Piping		mm	φ20×1.2	φ20×1.2	φ20×1.2
Dimensions (W×H×D) (Outline/Package)		mm	1270 ×268×504/ 1345×268×594	1251×290×744/ 1335× 290× 834	1251×290×744/ 1335× 290× 834
Weight (Net/Gross)		kg	37/45	57/67	57/67
Outdoor Unit			GUHN24NK3AO	GUHN36NM3AO	GUHN36NK3AO
Power Supply		—	220-240V~/1Ph/50HZ	380-415V~/3Ph/50HZ	220-240V~/1Ph/50HZ
Heat Exchange		—	Cross Fin Coil		
Fan	Type	—	Axial fan		
	Motor Output	kW	0.068×1	0.092×2	0.092×2
	Fan Motor Speed(H/M/L)	rpm	840/620/400	940/840/700	940/840/700
Compressor	Type	—	ROTARY	SCROLL	SCROLL
	Motor Output	kW	2.475	3.65	3.8
Refrigerant	Type	—	R410A		
	Control	—	Capillary Tube		
	Charge	kg	2.2	3.2	3.2
Dimensions (W×H×D) (Outline/Package)		mm	1018×700× 412/ 1100 ×755× 450	1018 ×8 40×412/ 1110 × 985 × 450	1018 ×8 40×412/ 1110 ×985 × 450
Weight (Net/Gross)		kg	59/64	90/100	90/100
Piping Connections	Liquid	mm	9.52	12.7	12.7
	Gas	mm	15.8	19.05	19.05
	Max. Length	m	30	50	50
	Max. Height Difference	m	15	30	30

Continued:2

Model	Indoor unit		GFH42K3BI	GFH48K3BI	GFH60K3BI
	Outdoor unit		GUHN42NK3AO	GUHN48NM3AO	GUHN60NM3AO
Nominal Capacity	Cooling	kW	12	14	16
		Btu/h	42000	48000	60000
	Heating	kW	14	15.5	18.5
		Btu/h	48000	53000	63120
Power Input	Cooling	kW	5.3	5.8	6.5
	Heating	kW	4.9	5.4	5.5
EER/COP		W/W	2.26/2.86	2.41/2.87	2.46/3.27
Indoor Unit			GFH42K3BI	GFH48K3BI	GFH60K3BI
Power Supply		—	220-240V~/1 Ph/50HZ		
Heat Exchange		—	Cross Fin Coil		
Fan	Type	—	Centrifugal fan		
	Drive	—	Direct Driver		
	Motor Output	kW	0.5×2		
	Air Flow	m ³ /h	2000	2300	2500
	Ext. Static Pressure	Pa	150	150	150
Sound Pressure Level (H/M/L)		dB(A)	50 / 48 /46	50 / 48 /46	53 / 50 /48
Air Filter		—	Standard washable synthetic		
Drain Piping		mm	φ20×1.2	φ20×1.2	φ32×1.5
Dimensions (W×H×D) (Outline/Package)		mm	1251×290×744/ 1335×290×834	1251×290×744/ 1335×290×834	1251×330×788/ 1334×330×882
Weight (Net/Gross)		kg	57/67	57/67	66/76
Outdoor Unit			GUHN42NK3AO	GUHN48NM3AO	GUHN60NM3AO
Power Supply		—	380-415V~/3 Ph/50HZ		
Heat Exchange		—	Cross Fin Coil		
Fan	Type	—	Axial fan		
	Motor Output	kW	0.092×2		
	Fan Motor Speed(H/M/L)	rpm	940/840/700	940/840/700	940/840/700
Compressor	Type	—	SCROLL		
	Motor Output	kW	4.75	4.5	5.75
Refrigerant	Type	—	R410A		
	Control	—	Capillary Tube		
	Charge	kg	3.55	3.8	5.0
Dimensions (W×H×D) (Outline/Package)		mm	1018×700×412 /1100×755×450	950×1250×412 /1110×1385×450	950×1250×412 /1110×1385×450
Weight (Net/Gross)		kg	112/123	112/123	123/134
Piping Connections	Liquid	mm	12.7	12.7	12.7
	Gas	mm	19.05	19.05	22.2
	Max. Length	m	50		
	Max. Height Difference	m	30		

Note:

- ① Nominal capacities are based on the follow conditions.

	Indoor	Outdoor
Cooling	DB: 27°C(80.6°F) WB: 19°C(66.2°F)	DB: 35°C(95°F) WB: 24°C(75.2°F)
Heating	DB: 20°C(68°F) WB: --°C(--°F)	DB: 7°C(44.6°F) WB: 6°C(42.8°F)
Piping Length	5m	

- ② The air volume is measured at the relevant standard external static pressure.
- ③ Noise is tested in the Semi anechoic Room, so it should be slightly higher in the actual operation due to environmental change.

4.1.2 Ceiling Type

Models	Indoor unit		GTH09K3BI	GTH12K3BI	GTH18K3BI
	Outdoor unit		GUHN09NK3AO	GUHN12NK3AO	GUHN18NK3AO
Nominal Capacity	Cooling	kW	2.6	3.5	5.0
		Btu/h	8870	11940	17060
	Heating	kW	2.85	3.6	5.7
		Btu/h	9720	12280	19448
Power Input	Cooling	kW	1	1.17	2.03
	Heating	kW	1	1.1	2.07
EER/ COP		W/W	2.6/2.85	2.99/3.55	2.46/2.8
Indoor Unit			GTH09K3BI	GTH12K3BI	GTH18K3BI
Power Supply		—	220-240V~/1 Ph/50HZ		
Heat Exchange		—	Cross Fin Coil		
Fan	Type	—	Centrifugal fan		
	Drive	—	Direct Driver		
	Motor Output	kW	0.01×2	0.01×2	0.04×2
	Air Flow	m ³ /h	550	550	700
Sound Pressure Level (H/M/L)		dB(A)	47/44/41	46/44/41	54/50/46
Air Filter		—	Standard washable synthetic		
Drain Piping		mm	φ28×1.5		
Dimensions (W×H×D) (Outline/Package)		mm	836×238×695/ 935×295×805	836×238×695/ 935×295×805	836×238×695/ 935×295×805
Weight (Net/Gross)		kg	27/35.5	27/35.5	32/36
Outdoor Unit			GUHN09NK3AO	GUHN12NK3AO	GUHN18NK3AO
Power Supply		—	220-240V~/1 Ph/50HZ		
Heat Exchange		—	Cross Fin Coil		
Fan	Type	—	Axial fan		
	Motor Output	kW	0.03	0.03	0.03
	Fan Motor Speed	rpm	850	850	850
Compressor	Type	—	ROTARY		
	Motor Output	kW	0.922	1.185	1.9
Refrigerant	Type	—	R410A		
	Control	—	Capillary Tube		
	Charge	kg	1.1	1.0	1.5
Dimensions (W×H×D) (Outline/Package)		mm	848×540×320 /878×590×360	848×540×320 /878×590×360	848×540×320 /878×590×360
Weight (Net/Gross)		kg	32/37	32/37	40/45
Piping Connections	Liquid	mm	6.35	6.35	6.35
	Gas	mm	9.52	12.7	12.7
	Max. Length	m	20	20	20
	Max. Height Difference	m	15	15	15

Continued 1

Models	Indoor unit		GTH24K3BI	GTH36K3BI	GTH36K3BI
	Outdoor unit		GUHN24NK3AO	GUHN36NM3AO	GUHN24NK3AO
Nominal Capacity	Cooling	kW	7.0	9.8	10
		Btu/h	23880	33440	36000
	Heating	kW	8.0	10.78	11
		Btu/h	27300	36780	37500
Power Input	Cooling	kW	2.61	3.6	3.6
	Heating	kW	2.59	3.3	3.3
EER/ COP		W/W	2.68/3.09	2.78/3.33	2.78/3.33
Indoor Unit			GTH24K3BI	GTH36K3BI	GTH36K3BI
Power Supply		—	220-240V~/1Ph/50HZ		
Heat Exchange		—	Cross Fin Coil		
Fan	Type	—	Centrifugal fan		
	Drive	—	Direct Driver		
	Motor Output	kW	0.1×4	0.085×2	0.085×2
	Air Flow	m ³ /h	1170	1800	1800
Sound Pressure Level (H/M/L)		dB(A)	50/48/46	54/51/48	54/51/48
Air Filter		—	Standard washable synthetic		
Drain Piping		mm	φ28×1.5		
Dimensions (H×W×D) (Outline/Package)		mm	1300×188×600 /1414×248×724	1590×238×695/ 1714×330×830	1590×238×695/ 1714×330×830
Weight (Net/Gross)		kg	32/36	42/51	42/51
Outdoor Unit			GUHN24NK3AO	GUHN36NM3AO	GUHN24NK3AO
Power Supply		—	220-240V~/1Ph/50HZ	380-415V~/3Ph/50HZ	220-240V~/1Ph/50HZ
Heat Exchange		—	Cross Fin Coil		
Fan	Type	—	Axial fan		
	Motor Output	kW	0.068	0.092×2	0.092×2
	Fan MotorSpeed(H/M/L)	rpm	840/620/400	940/840/700	940/840/700
Compressor	Type	—	ROTARY	SCROLL	SCROLL
	Motor Output	kW	2.475	3.65	3.8
Refrigerant	Type	—	R410A		
	Control	—	Capillary Tube		
	Charge	kg	2.2	3.2	3.2
Dimensions (W×H×D) (Outline/Package)		mm	1018 ×700×412/ 1100×755×450	1018×840×412/ 1110×985×450	1018×840×412/ 1110×985×450
Weight (Net/Gross)		kg	59/64	90/100	90/100
Piping Connections	Liquid	mm	9.52	12.7	12.7
	Gas	mm	15.8	19.05	19.05
	Max. Length	m	30	50	50
	Max. Height Difference	m	15	30	30

Continued 2

Models	Indoor unit		GTH42K3BI	GTH48K3BI
	Outdoor unit		GUHN42NM3AO	GUHN48NM3AO
Nominal Capacity	Cooling	kW	12	14
		Btu/h	42000	48000
	Heating	kW	14	15.5
		Btu/h	48000	53000
Power Input	Cooling	kW	4.8	6.1
	Heating	kW	4.7	5.8
EER/ COP		W/W	2.5/2.98	2.3/2.67
Indoor Unit			GTH42K3BI	GTH48K3BI
Power Supply		—	220-240V~/1Ph/50HZ	
Heat Exchange		—	Cross Fin Coil	
Fan	Type	—	Centrifugal fan	
	Drive	—	Direct Driver	
	Motor Output	kW	0.085×2	0.18×2
	Air Flow	m ³ /h	1800	2100
Sound Pressure Level (H/M/L)		dB(A)	54/51/48	58/55/52
Air Filter		—	Standard washable synthetic	
Drain Piping		mm	φ28×1.5	
Dimensions (W×H×D) (Outline/Package)		mm	1590×238×695 1714×330×830	1590×238×695/ 1714×330×830
Weight (Net/Gross)		kg	42/51	42/51
Outdoor Unit			GUHN42NM3AO	GUHN48NM3AO
Power Supply		—	380-415V~/3 Ph/50HZ	
Heat Exchange		—	Cross Fin Coil	
Fan	Type	—	Axial fan	
	Motor Output	kW	0.092×2	0.092×2
	Fan MotorSpeed(H/M/L)	rpm	940/840/700	940/840/700
Compressor	Type	—	SCROLL	
	Motor Output	kW	4.75	4.5
Refrigerant	Type	—	R410A	
	Control	—	Capillary Tube	
	Charge	kg	3.55	3.8
Dimensions (W×H×D) (Outline/Package)		mm	950×1250×412/ 1110×1385×450	950×1250×412/ 1110×1385×450
Weight (Net/Gross)		kg	112/123	
Piping Connections	Liquid	mm	12.7	
	Gas	mm	19.05	
	Max. Length	m	50	
	Max. Height Difference	m	30	

Note:

- ① Nominal capacities are based on the follow conditions.

	Indoor	Outdoor
Cooling	DB: 27°C(80.6°F) WB: 19°C(66.2°F)	DB: 35°C(95°F) WB: 24°C(75.2°F)
Heating	DB: 20°C(68°F) WB: --°C(--°F)	DB: 7°C(44.6°F) WB: 6°C(42.8°F)
Piping Length	5m	

- ② The air volume is measured at the relevant standard external static pressure.
- ③ Noise is tested in the Semianechoic Room, so it should be slightly higher in the actual operation due to environmental change.

4.1.3 Cassette Type

Models	Indoor unit		GKH12K3BI	GKH18K3BI	GKH24K3BI
	Outdoor unit		GUHN12NK3AO	GUHN18NK3AO	GUHN24NK3AO
Nominal Capacity	Cooling	kW	3.5	5.0	6.8
		Btu/h	11940	17060	23200
	Heating	kW	3.6	5.7	7.5
		Btu/h	12280	19450	25590
Power Input	Cooling	kW	1.17	2.0	2.62
	Heating	kW	1.1	1.9	2.5
EER/COP		W/W	2.8/3.2	2.5/3.05	2.67/3.2
Indoor Unit			GKH12K3BI	GKH18K3BI	GKH24K3BI
Power Supply		—	220-240V~/1 Ph/50HZ		
Heat Exchange		—	Cross Fin Coil		
Fan	Type	—	Centrifugal fan		
	Drive	—	Direct Driver		
	Motor Output	kW	0.011	0.011	0.035
	Air Flow	m ³ /h	550	600	1180
Sound Pressure Level (H/M/L)		dB(A)	47/45/43		
Air Filter		—	Standard washable synthetic		
Drain Piping		mm	φ31×3	φ31×3	φ32×3
Indoor Unit Dimensions (Outline/Package) (W×H×D)		mm	600×230×600/ 848×310×678	600×230×600/ 848×310×678	840×260×840/ 960×310×960
Panel Dimensions (Outline/Package) (H×W×D)		mm	50×650×650/ 102×730×670	50×650×650/ 102×730×670	60×950×950/ 115×1040×1025
Weight (Net/Gross)		kg	20/27	20/27	30 / 38
Outdoor Unit			GUHN12NK3AO	GUHN18NK3AO	GUHN24NK3AO
Power Supply		—	220-240V~/1 Ph/50HZ		
Heat Exchange		—	Cross Fin Coil		
Fan	Type	—	Axial fan		
	Motor Output	kW	0.03	0.03	0.068
	Fan Motor Speed(H/M/L)	rpm	850	850	840/620/400
Compressor	Type	—	ROTARY		
	Motor Output	kW	1.185	1.9	2.475
Refrigerant	Type	—	R410A		
	Control	—	Capillary Tube		
	Charge	kg	1.0	1.5	2.2
Dimensions (W×H×D) (Outline/Package)		mm	848×540×320/ 878×590×360	848×540×320/ 878×590×360	1018×700×412/ 1100×755×450
Weight (Net/Gross)		kg	32/37	40/45	59/64
Piping Connections	Liquid	mm	6.35	6.35	9.52
	Gas	mm	12.7	12.7	15.8
	Max. Length	m	20	20	30
	Max. Height Difference	m	15	15	15

Continued 1

Models	Indoor unit		GKH36K3BI	
	Outdoor unit		GUHN36NM3AO	
Nominal Capacity	Cooling	kW	10	10
		Btu/h	36000	36000
	Heating	kW	11	11
		Btu/h	37500	37500
Power Input	Cooling	kW	3.6	3.6
	Heating	kW	3.1	3.3
EER/COP		W/W	2.78/3.55	2.78/3.33
Indoor Unit			GKH36K3BI	GKH36K3BI
Power Supply		—	220-240V~/1 Ph/50HZ	
Heat Exchange		—	Cross Fin Coil	
Fan	Type	—	Centrifugal fan	
	Drive	—	Direct Driver	
	Motor Output	kW	0.06	
	Air Flow	m ³ /h	1600	1800
Sound Pressure Level (H/M/L)		dB(A)	53/51 /48	
Air Filter		—	Standard washable synthetic	
Drain Piping		mm	φ32×3	
Indoor Unit Dimensions (Outline/Package) (W×H×D)		mm	840×320×840/ 960×394×960	
Panel Dimensions (Outline/Package) (H×W×D)		mm	60×950×950/ 115×1040×1025	
Weight (Net/Gross)		kg	38/46	
Outdoor Unit			GUHN36NM3AO	GUHN36NK3AO
Power Supply		—	380-415V~/3Ph/50HZ	220-240V~/1Ph/50HZ
Heat Exchange		—	Cross Fin Coil	
Fan	Type	—	Axial fan	
	Motor Output	kW	0.092×2	
	Fan Motor Speed(H/M/L)	rpm	940/840/700	
Compressor	Type	—	SCROLL	
	Motor Output	kW	3.65	3.8
Refrigerant	Type	—	R410A	
	Control	—	Capillary Tube	
	Charge	kg	3.2	
Dimensions (W×H×D) (Outline/Package)		mm	1018× 840 ×412 1110 ×985×450	
Weight (Net/Gross)		kg	90/100	
Piping Connections	Liquid	mm	12.7	
	Gas	mm	19.05	
	Max. Length	m	50	
	Max. Height Difference	m	30	

Continued 2

Models	Indoor unit		GKH42K3BI	GKH48K3BI
	Outdoor unit		GUHN42NM3AO	GUHN48NM3AO
Nominal Capacity	Cooling	kW	12	14
		Btu/h	42000	48000
	Heating	kW	14	15.5
		Btu/h	48000	53000
Power Input	Cooling	kW	4.8	5.8
	Heating	kW	5.0	6.2
EER/COP		W/W	2.5/2.8	2.3/2.67
Indoor Unit			GKH42K3BI	GKH48K3BI
Power Supply		—	220-240V~/1 Ph/50HZ	
Heat Exchange		—	Cross Fin Coil	
Fan	Type	—	Centrifugal fan	
	Drive	—	Direct Driver	
	Motor Output	kW	0.06	
	Air Flow	m ³ /h	1650	1700
Sound Pressure Level (H/M/L)		dB(A)	53/ 51 /48	
Air Filter		—	Standard washable synthetic	
Drain Piping		mm	φ32×3	
Indoor Unit Dimensions (Outline/Package) (H×W×D)		mm	840×320×840/ 960×394×960	
Panel Dimensions (Outline/Package) (H×W×D)		mm	60×950×950/ 115×1040×1025	
Weight (Net/Gross)		kg	38/46	
Outdoor Unit			GUHN42NM3AO	GUHN48NM3AO
Power Supply		—	380-415V~/3 Ph/50HZ	
Heat Exchange		—	Cross Fin Coil	
Fan	Type	—	Axial fan	
	Motor Output	kW	0.092×2	
	Fan Motor Speed(H/M/L)	rpm	940/840/700	
Compressor	Type	—	SCROLL	
	Motor Output	kW	4.75	4.5
Refrigerant	Type	—	R410A	
	Control	—	Capillary Tube	
	Charge	kg	3.55	3.8
Dimensions (W×H×D) (Outline/Package)		mm	950×1250×412/ 1110 × 1385 ×450	
Weight (Net/Gross)		kg	112/123	
Piping Connections	Liquid	mm	12.7	
	Gas	mm	19.05	
	Max. Length	m	50	
	Max. Height Difference	m	30	

Note:

- ① Nominal capacities are based on the follow conditions.

	Indoor	Outdoor
Cooling	DB: 27°C(80.6°F) WB: 19°C(66.2°F)	DB: 35°C(95°F) WB: 24°C(75.2°F)
Heating	DB: 20°C(68°F) WB: --°C(--°F)	DB: 7°C(44.6°F) WB: 6°C(42.8°F)
Piping Length	5m	

- ② The air volume is measured at the relevant standard external static pressure.
- ③ Noise is tested in the Semianechoic room, so it should be slightly higher in the actual operation due to environmental change.

4.2 Operation Range

Mode	Range of Outdoor Temperature °C (°F)
Cooling	18°C-43°C -7°C-43°C(with low Ambient kit)
Heating	-7°C-24°C

4.3 Electrical Data

Model		Compressor			Fan Motor		Max. Fuse Breaker Size (Indoor/Outdoor)	Min. Disconnect Size (Indoor/Outdoor)	
		Power Supply	Qty.	LRA	RLA	Condenser Fan Motors			Supply Blower Motor
		V,Ph,HZ	—	Each	Each	FLA Each	FLA Each	Amperes	Amperes
GUHN09NK3AO	GFH09K3BI	220-240 1 50	1	18	4.28	0.27	0.18	6/10	1/5.7
	GTH09K3BI						0.09	6/10	1/5.7
GUHN12NK3AO	GFH12K3BI		1	32	5.6	0.27	0.18	6/13	1/7.3
	GTH12K3BI						0.09	6/13	1/7.3
	GKH12K3BI						0.1	6/13	1/7.3
GUHN18NK3AO	GFH18K3BI		1	40	8.8	0.27	0.63	6/20	1.5/11.3
	GTH18K3BI						0.36	6/20	1/11.3
	GKH18K3BI						0.1	6/20	1/11.3
GUHN24NK3AO	GFH24K3BI		1	60	11.2	0.61	1.35	6/25	2.5/14.6
	GTH24K3BI						0.9	6/25	1.5/14.6
	GKH24K3BI						0.32	6/25	1/14.6
GUHN36NK3AO	GFH36K3BI		1	97	18.42	0.8	4.5	10/40	5.7/23.8
	GTH36K3BI						1.35	6/40	2.5/23.8
	GKH36K3BI						0.54	6/40	1/23.8
GUHN36NM3AO	GFH36K3BI		1	67	6.58	0.8	4.5	10/16	5.7/9.1
	GTH36K3BI						1.35	6/16	2.5/9.1
	GKH36K3BI						0.54	6/16	1/9.1
GUHN42NM3AO	GFH42K3BI		380-415~ 3 50	1	66	8.22	0.8	4.5	10/20
	GTH42K3BI	1.35						6/20	2.5/11.1
	GKH42K3BI	0.54						6/20	1/11.1
GUHN48NM3AO	GFH48K3BI	1	59.4	8	0.8	4.5	10/16	5.7/10.8	
	GTH48K3BI					1.62	6/16	2.5/10.8	
	GKH48K3BI					0.54	6/16	1/10.8	
GUHN60NM3AO	GFH60K3BI	1	67	9.77	0.8	4.5	10/20	5.7/13	

Notes:

RLA: Rated load amperes

LRA: Locked rotor amperes

FLA: Full load current

5 PIPING DIAGRAM

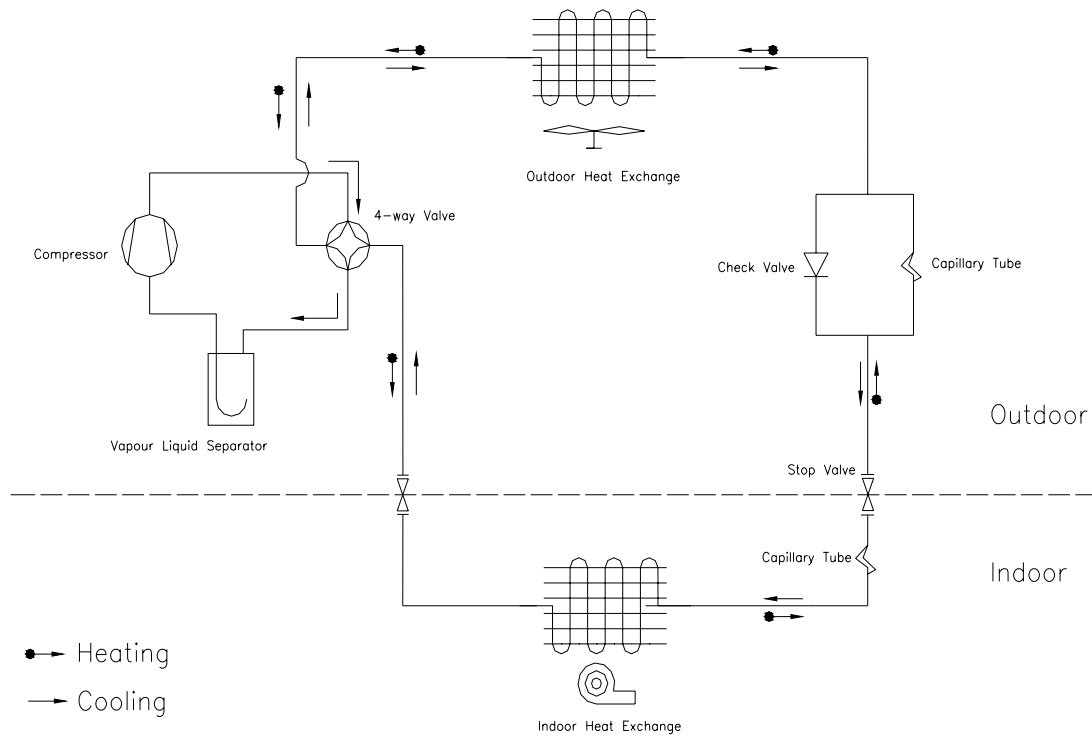

CONTROL

CONTROL

1 OPERATION FLOWCHART

1.1 Cooling/Dry Operation

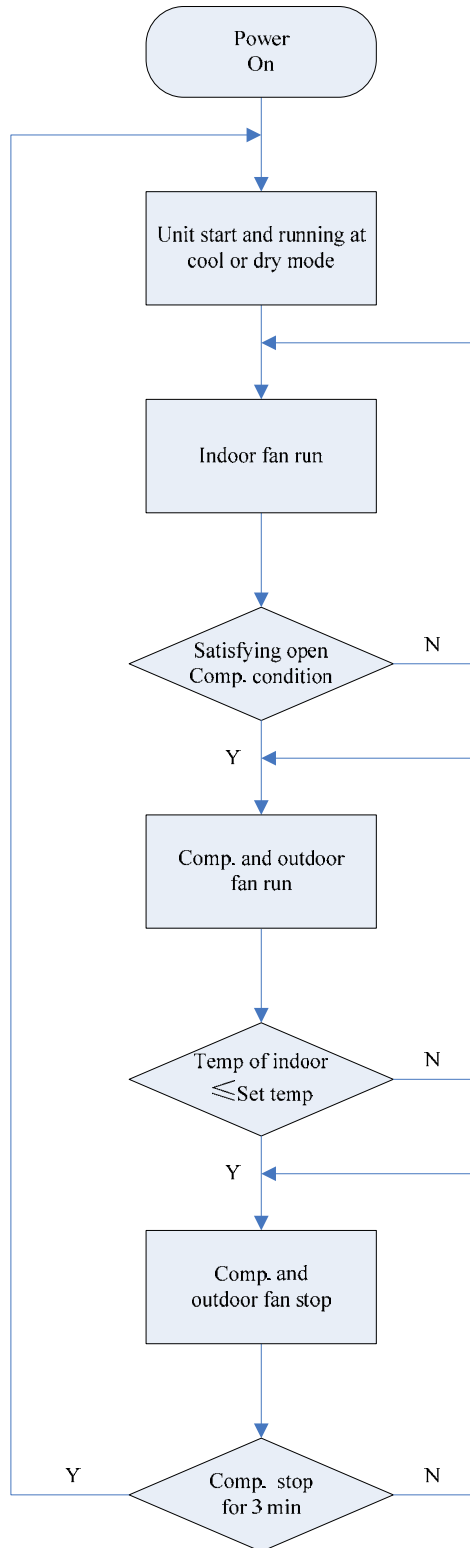

1.2 Heating Operation

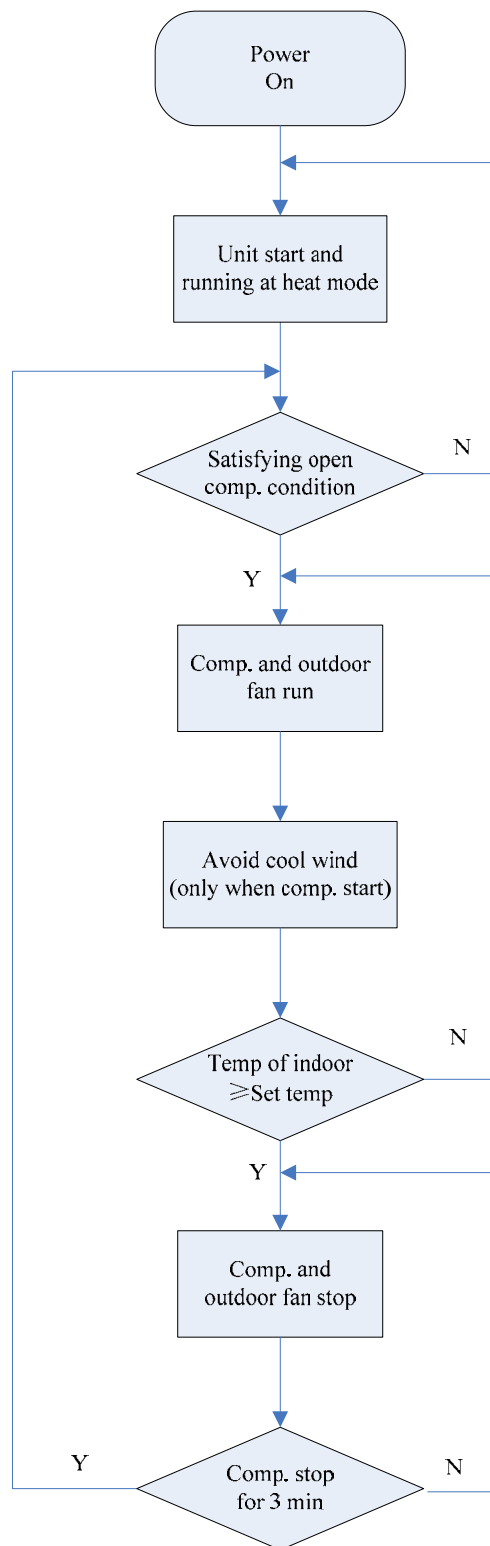

2 MAIN LOGIC

2.1 Cooling

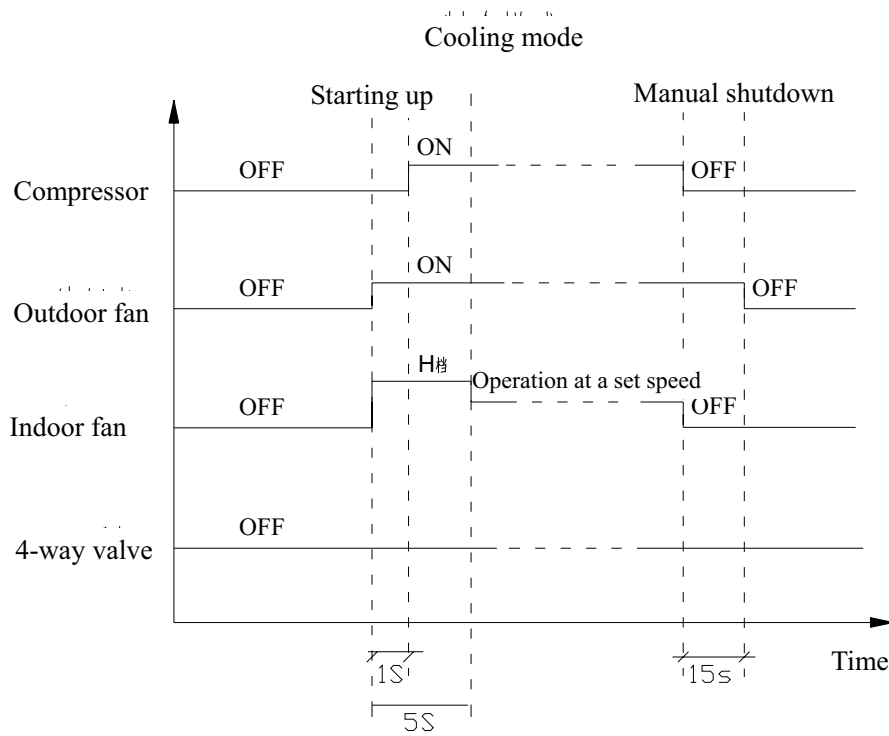

When $T_{环} \geq T_{设} + 1^{\circ}\text{C}$, the machine begins refrigeration operation and the compressor the outdoor fan are running; and the indoor fan is running at a set speed.

When $T_{amb.} \leq T_{设} - 1^{\circ}\text{C}$, the machine is in the refrigeration shutdown state, and the compressor and the outdoor fan stop running; and the indoor fan is running at a set speed.

When $T_{设} - 1^{\circ}\text{C} < T_{amb.} < T_{设} + 1^{\circ}\text{C}$, the machine keeps in the operation state.

2.2 Dry Mode

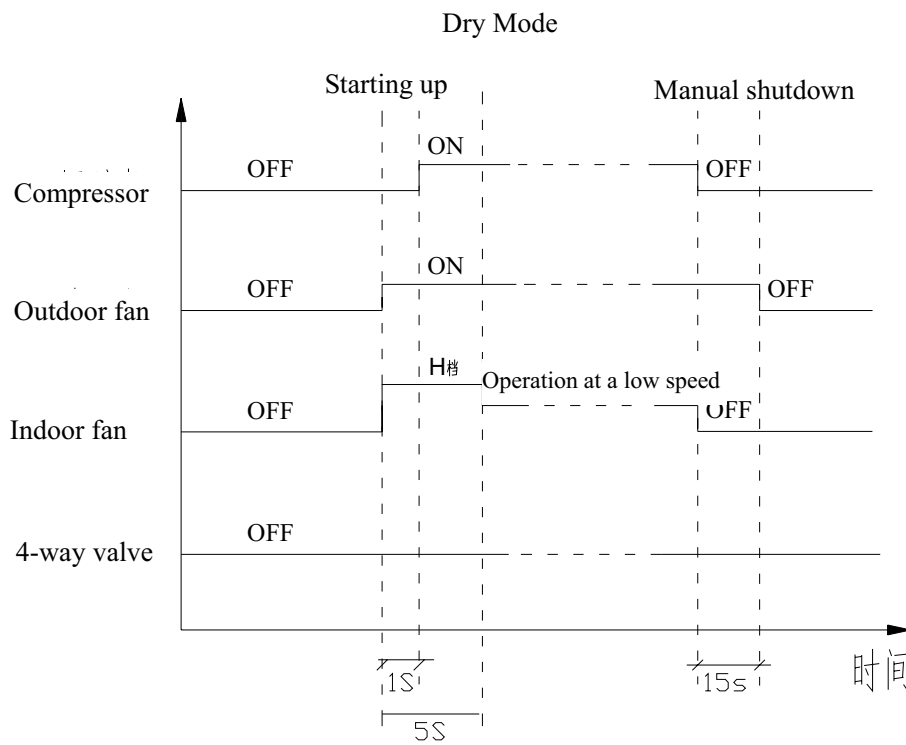

When $T_{amb} \geq T_{preset} + 2^{\circ}C$, the machine begins refrigeration operation and the compressor and the outdoor fan are running; and the indoor fan is running at a low speed.

When $T_{amb} \leq T_{preset} - 2^{\circ}C$, the machine is in the refrigeration shutdown state and the compressor and the outdoor fan stops running.

When $T_{set} - 2^{\circ}C < T_{amb} < T_{preset} + 2^{\circ}C$, the machine is in the six-minute stop and four-minute operation state, that is, the compressor runs for 6 minutes and then stops for 4 minutes, in such cycle repeatedly; and the indoor fan operates at a low speed.

2.3 Heating Mode

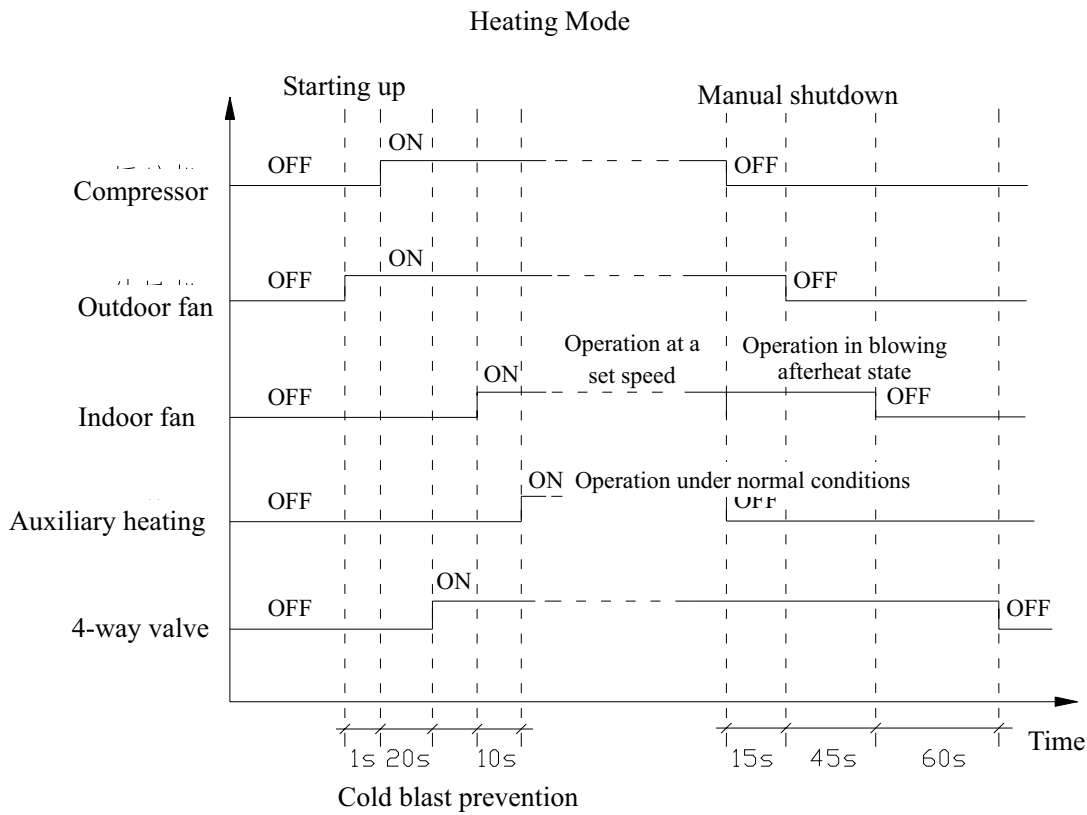

When $T_{amb.} \leq T_{preset} - 1^{\circ}C$, the machine begins heating operation and the compressor and the outdoor fan are running; and the indoor fan is running at a set speed according to cold fan prevention conditions.

When $T_{amb.} \geq T_{preset} + 1^{\circ}C$, the compressor and the outdoor fan stop running and the four-way valve keeps energized; and the indoor fan is running according to afterheat blowing conditions.

When $T_{set} - 1^{\circ}C < T_{amb.} < T_{preset} + 1^{\circ}C$, the machine keeps in the previous operation state.

2.4 Defrosting

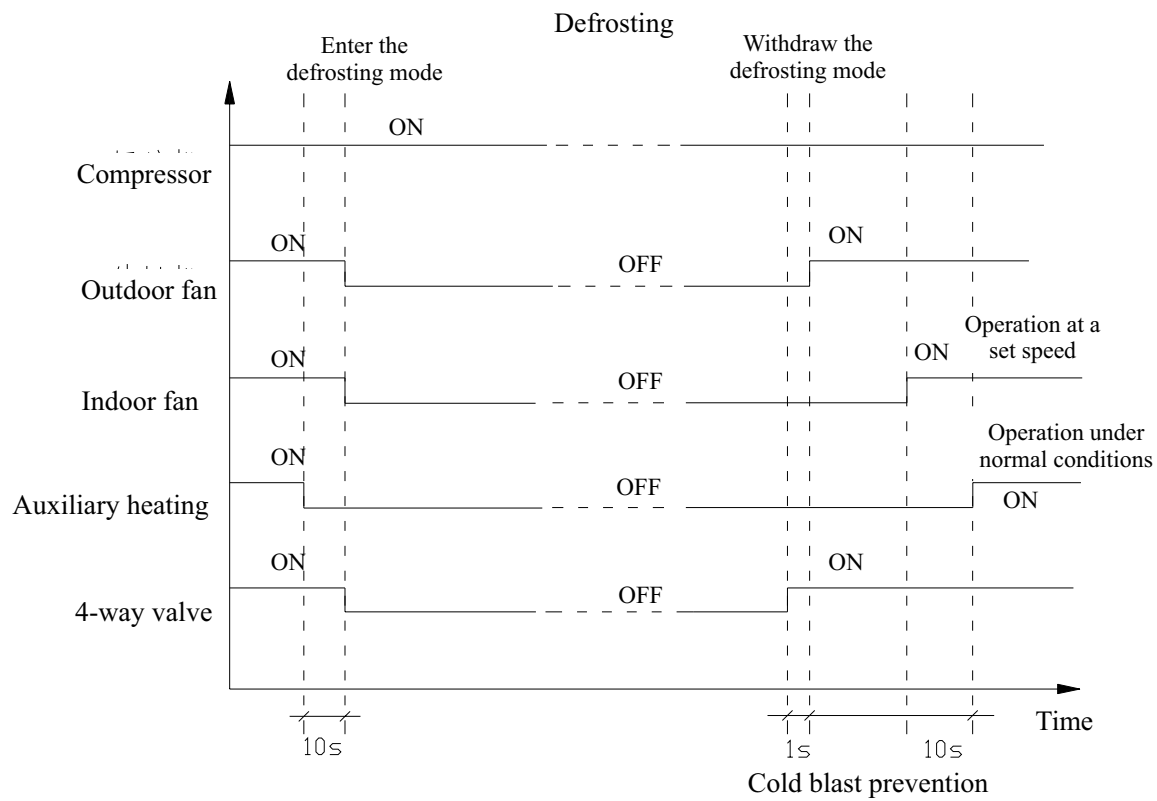

Defrosting start conditions: after the heating operation runs for an accumulated period of 44 minutes and the compressor continues to operate for 4 hours and 50 seconds, and a one-minute duration of $T_{\text{cond.}} \leq -5^{\circ}\text{C}$ is detected, the machine begins defrosting. If an auxiliary heater is available, it must be stopped firstly, and after 10 seconds, the four-way valve, the indoor fan, the outdoor fan and the compressor will run compulsively.

Defrosting completion conditions: when defrosting runs 10 minutes or $T_{\text{cond.}} \geq 10^{\circ}\text{C}$, defrosting will be completed. In such case, the four-way valve is running, the outdoor fan is running, the compressor is running compulsively, and the indoor fan operates according to cooling fan proof conditions.

2.5 Fan Mode

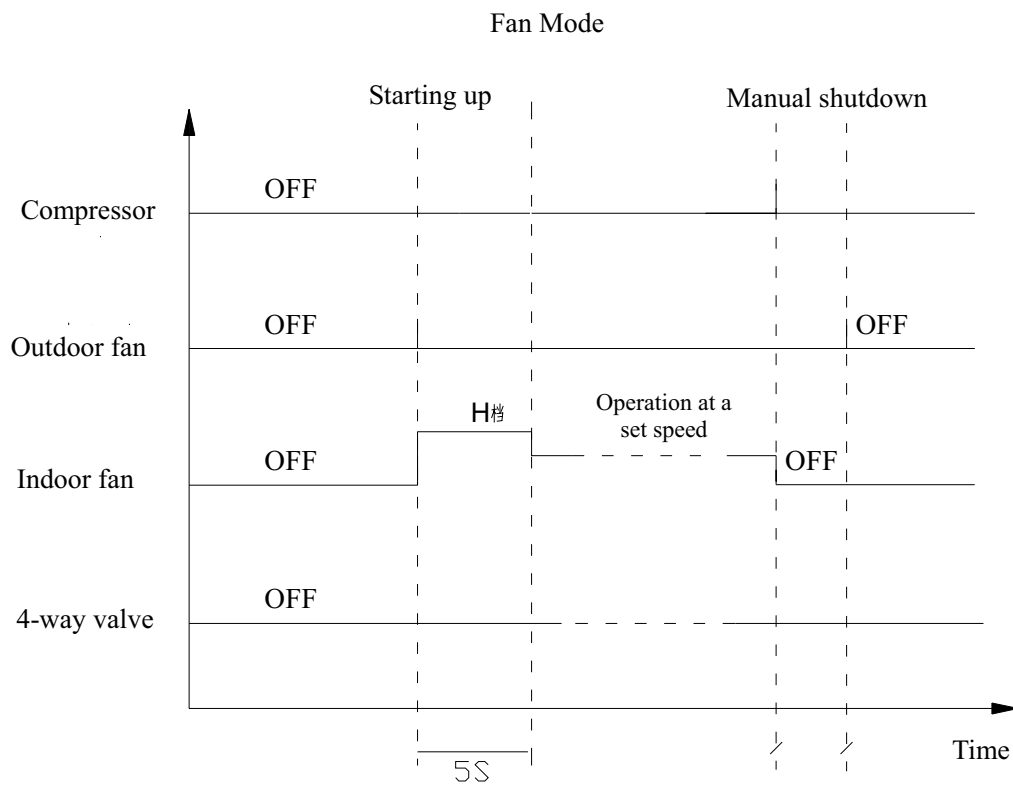

The indoor fan runs at a fast speed for 5s and then runs at a set speed.

3 WIRELESS REMOTE CONTROLLER

3.1 Operation View

(1) Controller-Duct Type

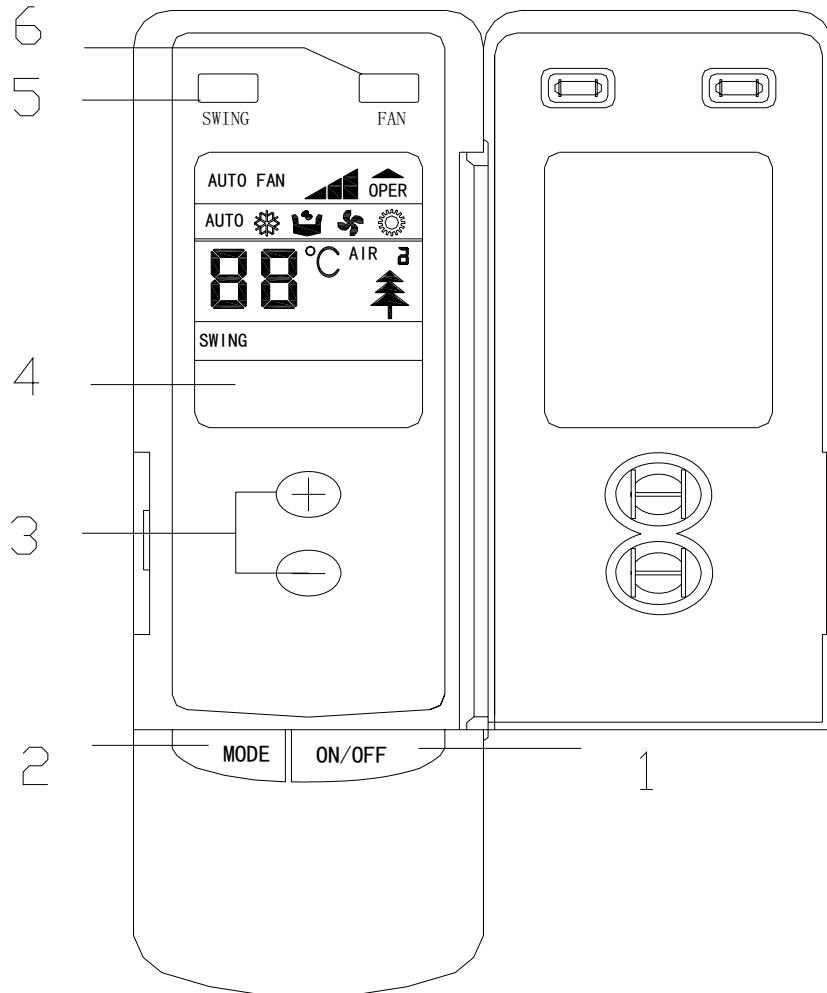

NO.	Name	Function description
1	ON/OFF button	Press the button to set start or close unit
2	Mode button	Press the button to select the mode, cooling , heating , fan or auto mode.
3	Increase/Decrease button	Press this button to increase/decrease the setup temp
4	LCD Screen	Display the status of remote information
5	Swing button	Press this button set swing function
6	Fan speed button	Press this button to set fan speed

(2)Controller-Cassette Type and Ceiling Type

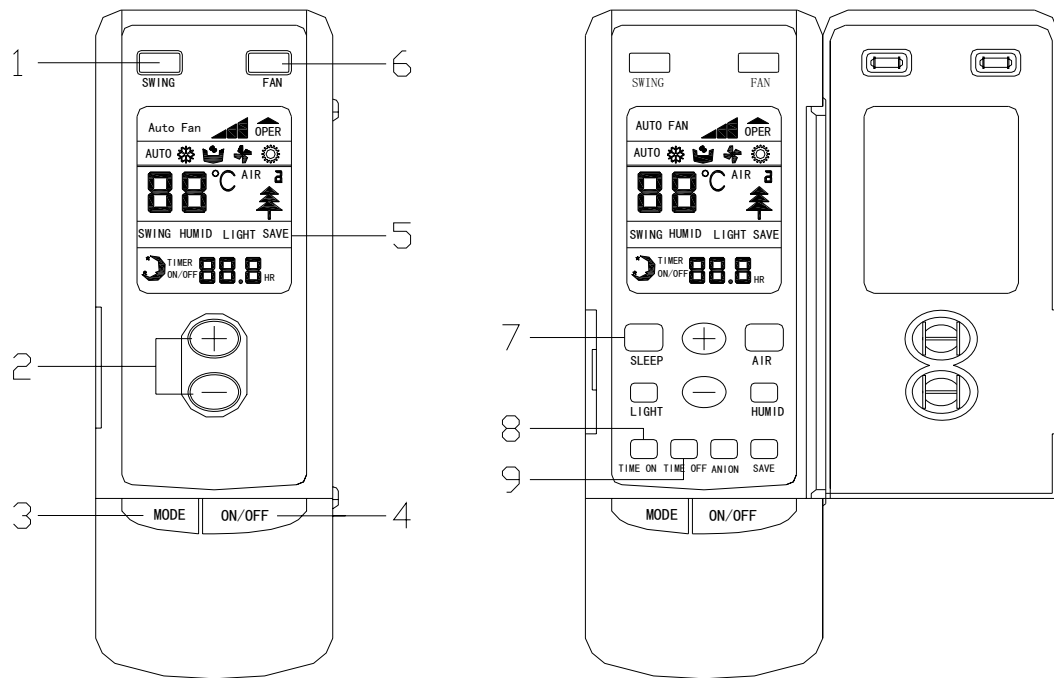

NO.	Name	Function description
1	Swing button	Press this button to set swing function
2	Increase/Decrease button	Press this button to increase/decrease the setup temp
3	Mode button	Press the button to select the mode, cooling , heating , fan or auto mode.
4	ON/OFF button	Press the button to set start or close unit
5	LCD Screen	Display the status of remote information
6	Fan speed button	Press this button to set fan speed
7	Sleep button	Press the button to set sleep function
8	Time on	Press the button to set time on function
9	Time off	Press the button to set time off function

3.2 Display View

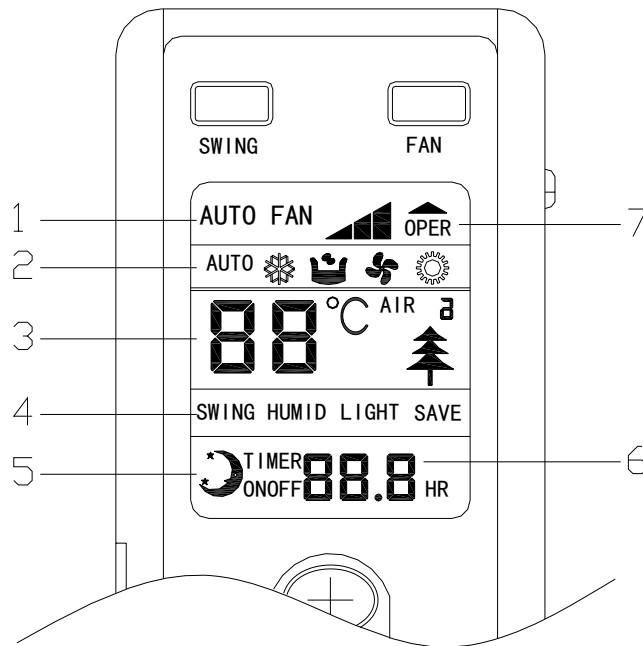

No.	Display	Function description
1	Fan Speed	AUTOFAN: auto fan speed、: low fan speed、 : middle fan speed : high fan speed,
2	Run Mode	AUTO: Auto running; : Cool running; : Dry Running; : Fan Running; : Heat running (Heat and Cool unit only)
3	Setup temp	Temperature value of setting
4	Swing function	Swing is on
5	Sleep mode	Sleep mode is on
6	Time value	Timing value of setting
7	OPER	The controller is on

4 WIRED REMOTE CONTROLLER

4.1 Operation View

(1) Wired Controller-Duct Type

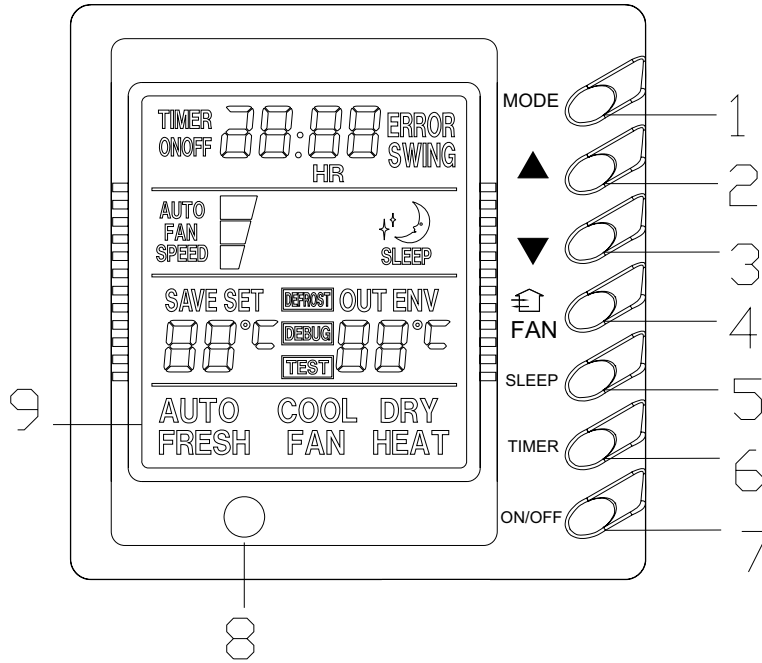

(2) Wired Controller-Cassette Type and Ceiling Type

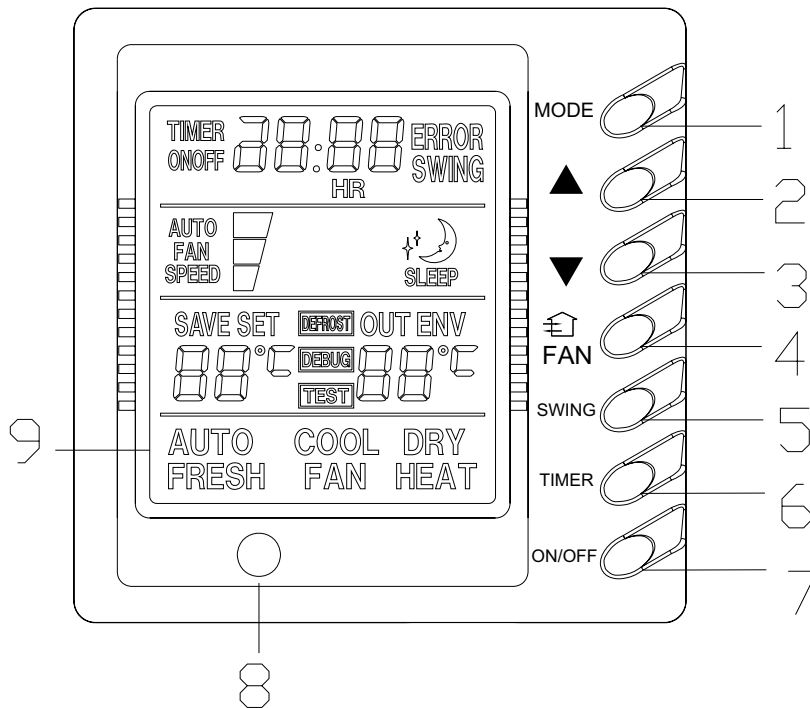

NO.	Name	Function description
1	MODE button	Press the button to select the mode, cooling , heating , fan or auto mode.
2	Increasing button	Press this button to increase the setup temp.
3	Decreasing button	Press this button to decrease the setup temp.
4	Fan speed button	Press this button to set fan speed
5	Sleep/SWING button	Press the button to set sleep/swing function
6	Timer button	Press the button to set timer function
7	On/off button	Press the button to set start or close unit
8	Remote window	Get remote information
9	LCD display	Display unit information

Note:

- (1) **SAVE set up** : At unit turned off, to press the “FAN” + “▼” buttons continuously 5 seconds, it can come enter save set up interphase, the unit will run at save mode.
- (2) **FRESH valve setup** : At unit is turned off, press the “ FAN” button for 5seconds,And set up the fresh air setup.
- (3) **Outer ambient temperature display:** Under normal condition, “ENV” will display the room ambient temperature, at unit turned on, or unit turned off status, press “SLEEP/SWING” button last for 5 seconds, the LCD will display “OUT ENV”.
- (4) **MEMORY function setup:** At unit turned off, press “MODE” button for 10 seconds, could switch whether turn on or off the unit state after powered off.
- (5) **Debugging function:** At unit off, continuously press “FAN” + “SLEEP” buttons lasting for 10seconds, call out debugging menu, and displays “Debugging” icons, use “MODE” button adjust setting item, by pressing “▲”、 “▼” button to set up the detailed value.
(A) Ambient sensor set up: it can set three kinds styles.
- (6) **Lock function:** Press “▲”and“▼” at the same time for 5 seconds, the set temp. will display “EE” and shield, all buttons will sound; and repress the“▲”and “▼”at the same time for 5 seconds, the lock function will be released.
(for details, please read corresponding parts of manual).

4.2 Display View

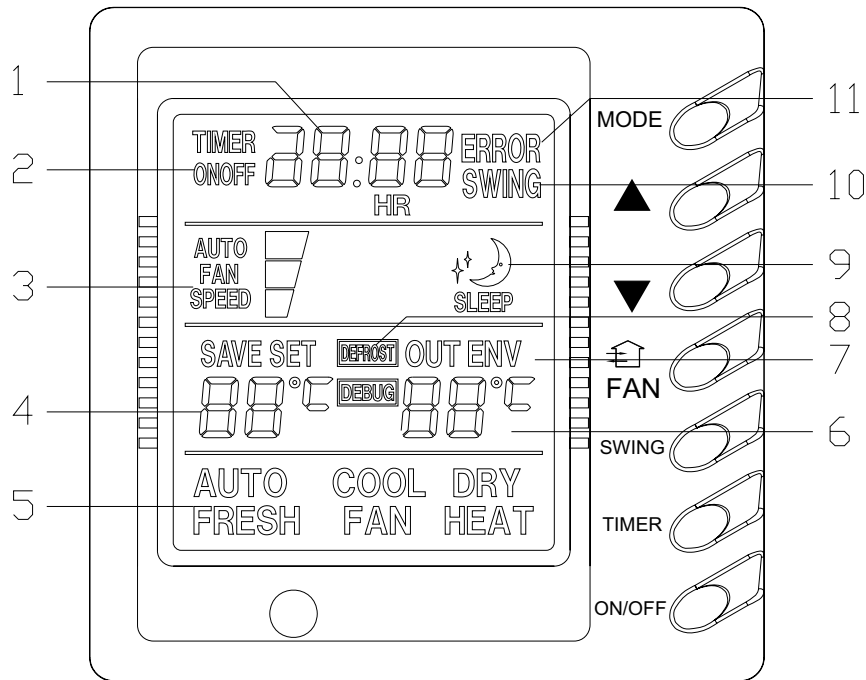

NO.	Name	Function description
1	Timer value	Display time value
2	Timer on/off	TIMER ON : display timer on, TIMER OFF :display timer off,
3	Fan speed display	AUTO FAN SPEED: auto fan speed, : low fan speed, : middle fan speed, : high fan speed
4	Set temp display	Display set temp value, its range is 16~30 °C
5	Run mode display	AUTO: auto mode, COOL: cool mode, DRY: dry mode, FRESH: fresh fan mode, FAN: fan mode, HEAT: heat mode(only cool and heat unit)
6	Indoor temp display	Display surrounding temp indoor
7	Outdoor temp display	Display surrounding temp outdoor
8	Frost display	When unit frosts ,it display
9	Sleep display	Display sleep at Sleep mode
10	Swing display	When setting swing function, it displays,
11	Error display	When unit error, error code display

4.3 Dimension

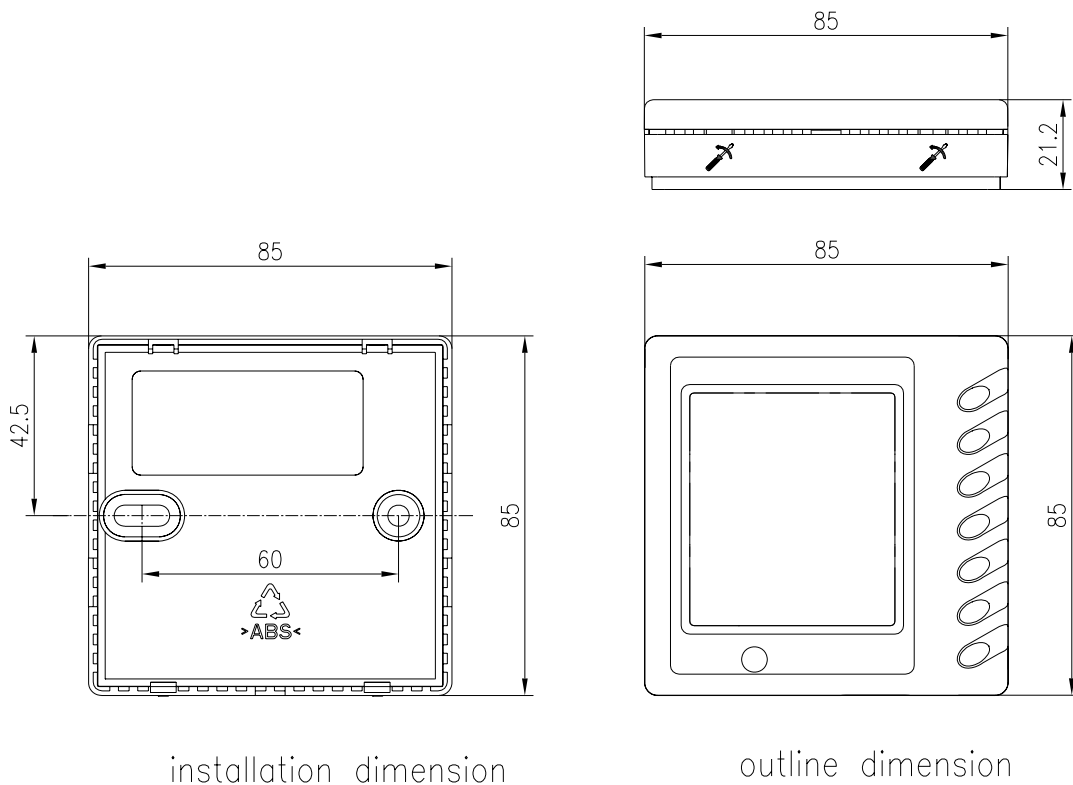

4.4 Installation

1. First select an installation position. According to the size of the communication line of the wire controller, leave a recess or a embedded wire hole to bury the communication line.
2. If the communication line between the wire controller (85×85×20) and the indoor unit is surface-mounted, use 1# PVC pipe and make matching recess in the wall (refer to Figure 6); If concealed installation is adopted, 1# PVC pipe can be used (Refer to Figure 7).
3. No matter if surface mounting or concealed mounting is selected, it is required to drill 2 holes (in the same level) which distance shall be the same as the distance (60mm) of installation holes in the bottom plate of the wire controller. Then insert a wood plug into each hole. Fix the bottom plate of the wire controller to the wall by using the two holes. Plug the communication line onto the control panel. Lastly install the panel of the wire controller.

Caution:

During the installation of the bottom plate of the wire controller, pay attention to the direction of the bottom plate. The plate's side with two notches must be at the lower position, and otherwise the panel of the wire controller cannot be correctly installed.

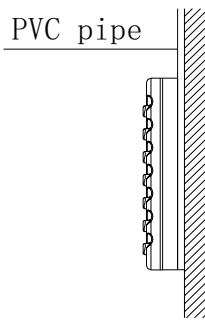

Fig6: Surface Mounting of Cable

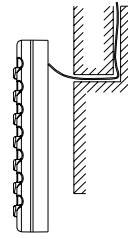

Fig7: Concealed mounting of Cable

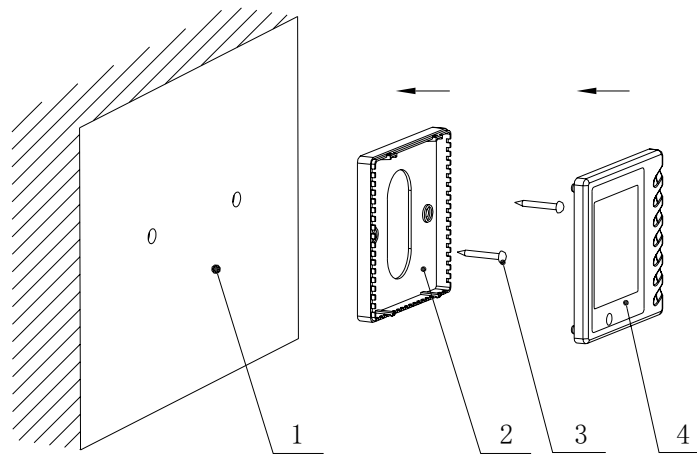

Fig 8 Schematic Diagram of Installation

No.	Name
1	Wall Surface
2	Bottom Plate of Wire Controller
3	Screw M4X10
4	Panel of Wire Controller

⚠ Caution:

1. The communication distance between the main board and the wire controller can be as far as 20m (The standard distance is 8m).
2. The wire controller shall not be installed in a place where there is water drop or large amount of water vapor.

5 CENTRALIZED CONTROLLER

5.1 Centralized Controller-not with week timer

5.1.1 Function

Centralized Controller-not with week timer only control on-off function of every units. Up to 16 sets of units can be controlled simultaneously by the centralized controller-not with week timer.

5.1.2 Operation View

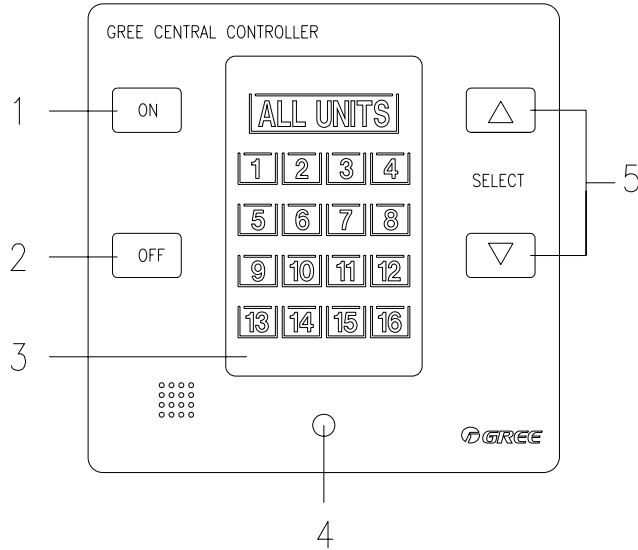

NO.	Name	Function description
1	ON button	Press the button to set start unit
2	OFF button	Press the button to set close unit
3	LCD display	Display unit information
4	LED	LED indication
5	Increasing / Decreasing button	Press buttons select the unit

5.1.3 Display View

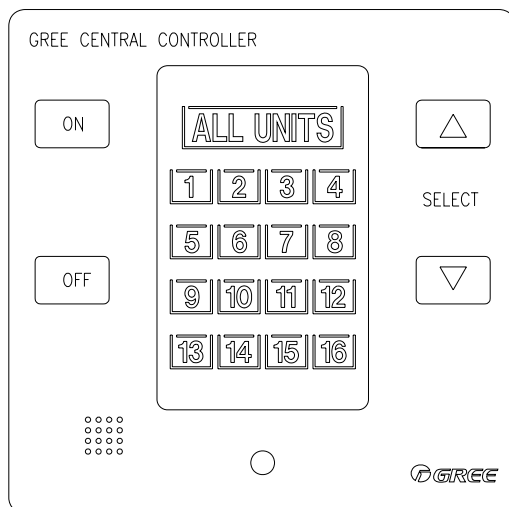

Display unit address value in the net.

5.1.4 Dimensions

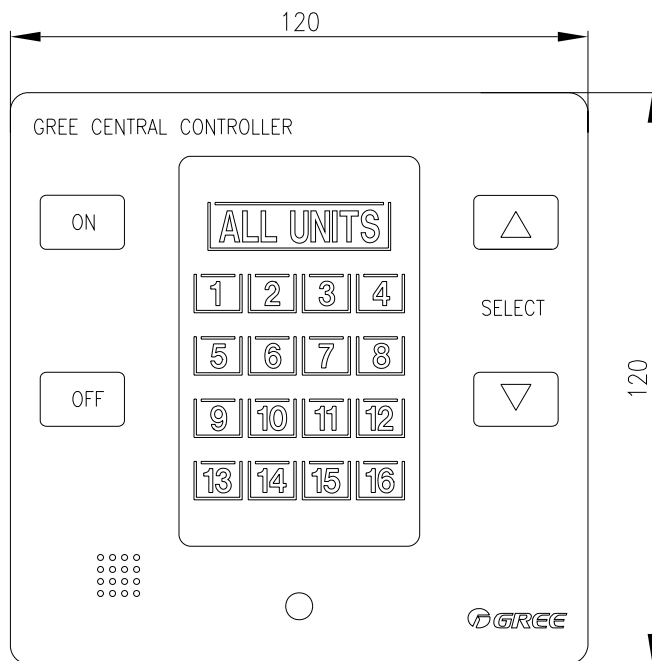

5.2 Centralized Controller-week timer

5.2.1 Function

Centralized Control and Week Timer Functions: The centralized controller and the weekly timer are integrated in the same wire controller. The system has both the centralized control and the week timing functions. Up to 16 sets of units can be controlled simultaneously by the centralized controller (weekly timer). The weekly timer has the function of invalidating the lower unit. The weekly timing function is able to realized four timing ON/OFF periods for any unit every day, so as to achieve fully automatic operation. No timing control can be set for holidays. On and off of every duct type unit can be done through the Timer On / Off of this WEEKLY TIMER, it can not set other functions except on-off function of units.

5.2.2 Operation View

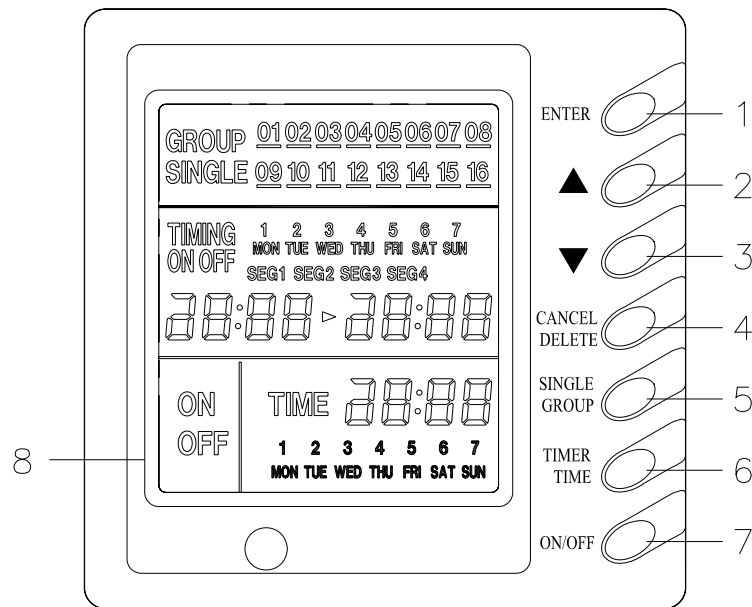

NO.	Name	Function description
1	ENTER button	when “enter” is pressed the setting is validate.
2	Increasing button	Press “▲” and selected the unit or a certain day in one week or specific value. Press “▲” can set week part of time.
3	Decreasing button	Press “▼” and selected the unit or a certain day in one week or specific value. Press “▼” can set week part of time.
4	CANCEL/DELETE button	short-press “cancel/delete” to back to default page or last process, long-press “cancel/delete” to cancel timer of a certain time period in a certain day
5	SINGLLE/GROUP button	short-press “single/group” to enter single control setting. “SINGLE” displayed. long-press “single/group” to enter group control setting. “GROUP” displayed
6	TIMER/TIME button	Short-press “timer/time” to enter timer setting. Long-press “timer/time” under default page can begin time setting.
7	On/off button	Control unit run or stop
8	LCD display	Display unit information

5.2.3 Display View

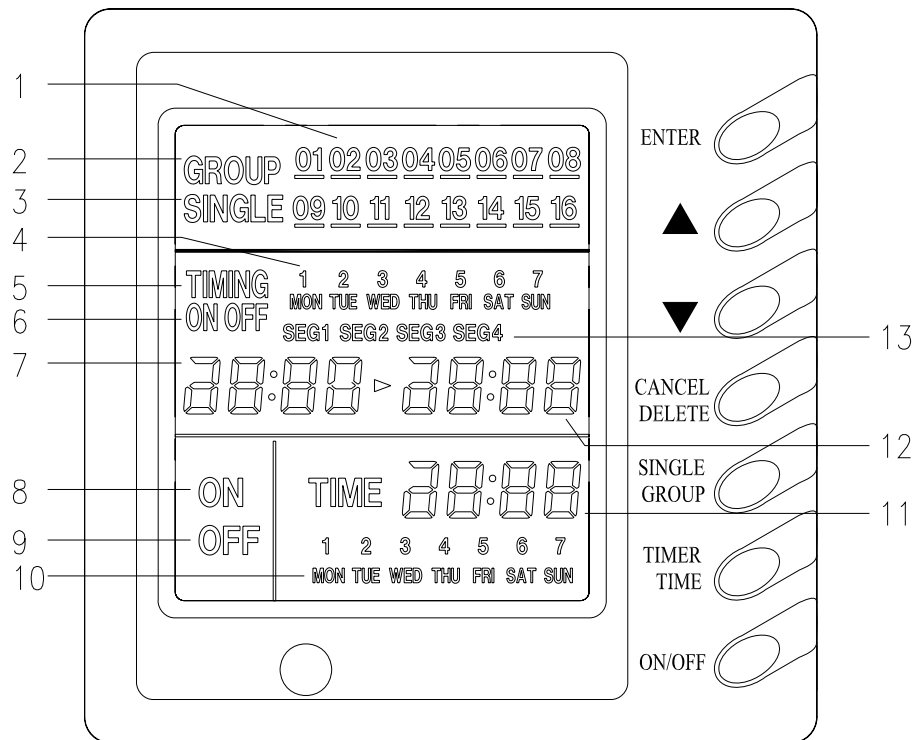

NO.	Name	Function description
1	unit's no. displays	Display unit's numbers
2	Group control displays	when group controls, it will display
3	Single control displays	when single unit controls, it will display
4	Timer time in week displays	Display time in week
5	Timer displays	Display time
6	timer state displays	"on": when set unit on, "on" will display; "off": when set unit off, "off" will display;
7	timer on time displays	Display starts time
8	on control displays	When set unit or group on, it will display,
9	off control displays	When set unit or group off, it will display,
10	present time in week display	Display present time of week.
11	present time in Hr:Min displays	Display time of hour and minute now
12	timer off time displays	Display over time
13	timer period displays	Set to different time segment

Note

Please read corresponding manual of weekly timer controller to be familiar with it.

5.2.4 Dimensions

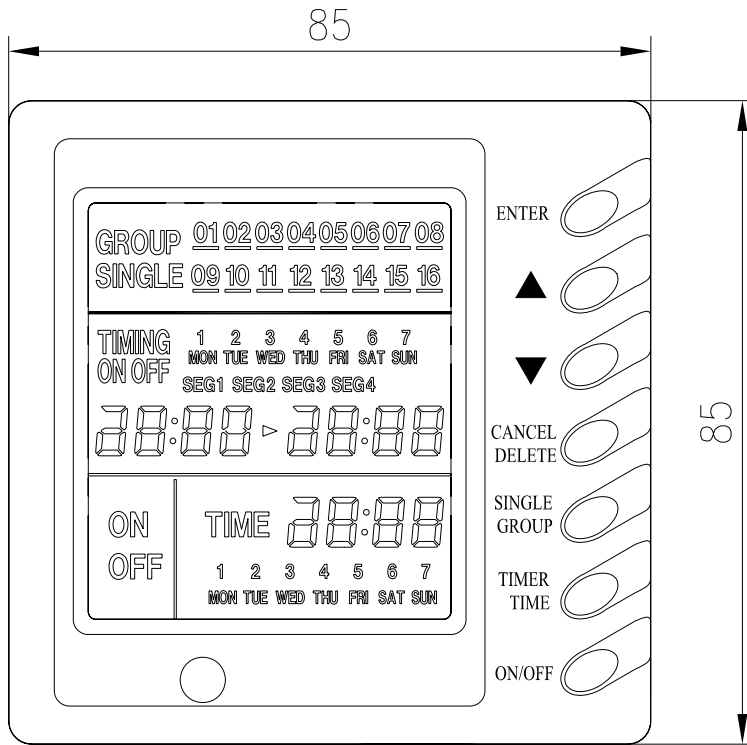

5.3 Field Setting

The centralized controller displays code of various units: unit code is determined by the position (on the back of the manual operator) of the toggle switch of the manual operator on each flue pipe air conditioner. Toggling values are corresponding to the 4-1 feet from the right to left of the toggle switch. “ON” stands for “0”, and conversely, “OFF” stands for “1”

Example 1: to get “0111”, which represents the serial number “8”, you can put foot 1, 2 and 3 of the toggle switch to the opposite of “ON” and foot 4 to “ON”.

Example 2: to get “1010”, which represents the serial number “11”, you can put foot 2 and 4 of the toggle switch to the opposite of “ON” and foot 1 and 3 to “ON”.

Position	Serial No.	Position	Serial No.	Position	Serial No.	Position	Serial No.
0000	1	0100	5	1000	9	1100	13
0001	2	0101	6	1001	10	1101	14
0010	3	0110	7	1010	11	1110	15
0011	4	0111	8	1011	12	1111	16

As shown in the following diagram:

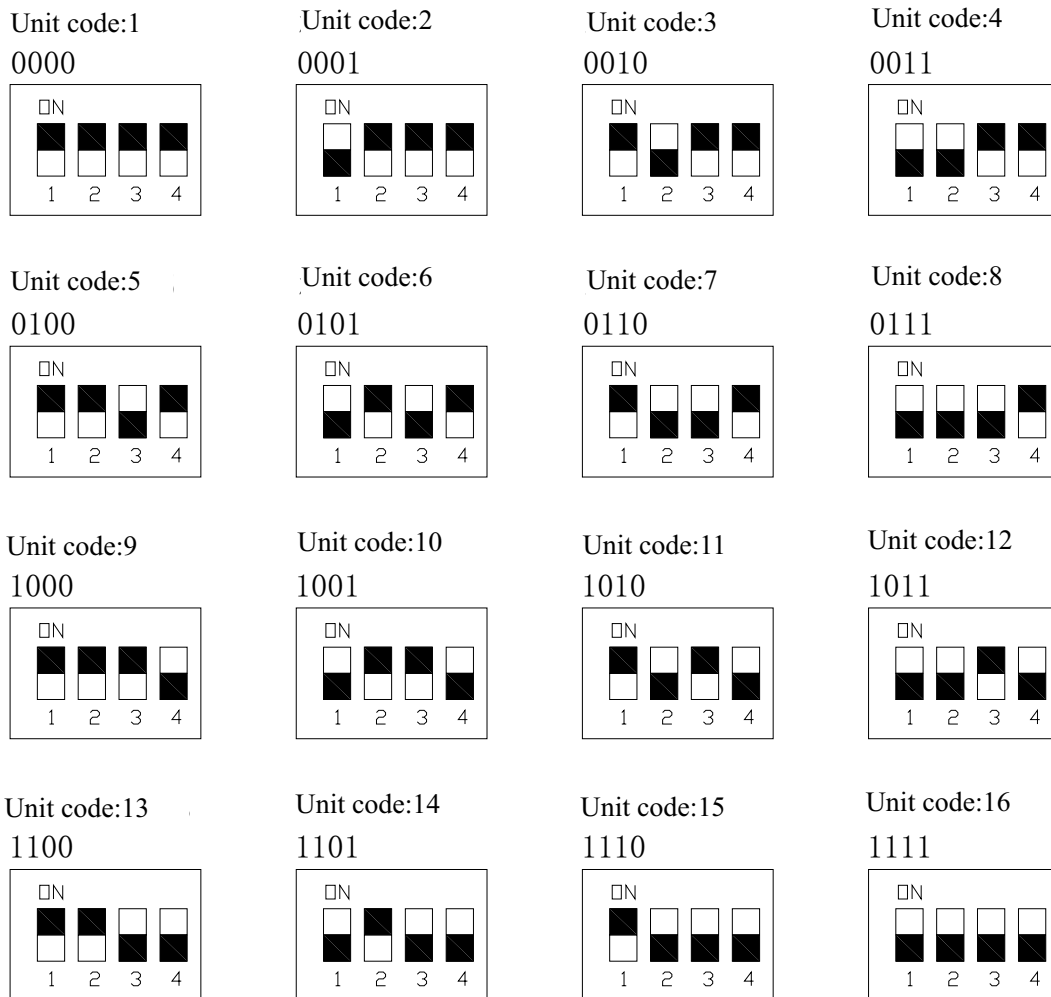

5.4 Control Wiring Design

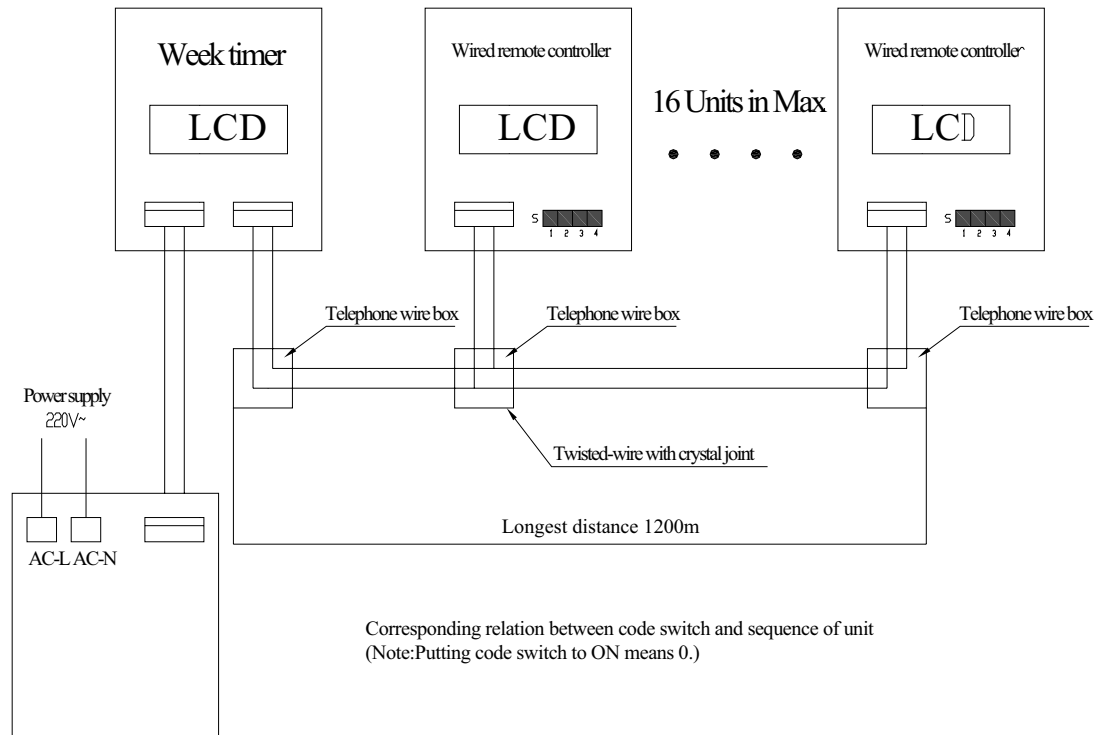

P	S	P	S	P	S	P	S
0000	1	0010	5	0001	9	0011	13
1000	2	1010	6	1001	10	1011	14
0100	3	0110	7	0101	11	0111	15
1100	4	1110	8	1101	12	1111	16

INSTALLATION

INSTALLATION

1 INDOOR UNIT INSTALLATION

1.1 Installation of Duct Type

1.1.1 Before Installation

- ◆ When the machine arrives, please check if any damage due to transport is existent. If any hurt is found on the surface or inside, please declare to the transport company or the manufacturer in writing.
- ◆ Upon receipt of the machine, the unit and accessories shall be checked in accordance with the packing list. Before acceptance, it must be confirmed that the model is correct and the unit is in good shape and specification and quantity of accessories are right.
- ◆ Correct handling route and method shall be decided to prevent damage to the unit. For protecting the unit and ensuring its safety, carrying the unit with its package is recommended. If such carrying method is difficult under particular conditions, the canton shall not be removed to avoid looseness or falling during handling
- ◆ Confirm the foundation is secure. When the unit is installed on the metal part of a building, electrical insulation must be in compliance with relevant standards.
- ◆ Confirm the installation position is away from storage zone of inflammable and explosive substances, or otherwise leakage of inflammable and explosive substances may lead to explosion or a fire.

1.1.2 Installation Site

- ◆ Ensure the top hanging piece has strong strength to withstand the weight of the unit.
- ◆ The drainage pipe has convenient flow of water.
- ◆ There is no obstacle blocking the air intake and exhaust outlet, so as to ensure sound air circulation.
- ◆ The installation spaces required by the drawing must be ensured, so as to provide enough space for the service and maintenance.
- ◆ The installation site must be far away from heat source, leakage of inflammable gas or smoke.
- ◆ The indoor unit is of ceiling mount (indoor unit is hidden inside the ceiling).
- ◆ The indoor and outdoor units, the power cable and the connecting electrical lines must be at least 1 meter from any TV set or radio. This is to avoid image interference or noise of the TV set or radio. (Even if the distance is 1 meter, noise can also exist if there is strong electric wave.)

1.1.3 Caution for Installation

- 1) Ceiling installation mode is applicable to units indoors. The suspender on the ceiling must have sufficient intensity to bear the weight of the unit.
- 2) Rubber cushion pads (thickness $\geq 20\text{mm}$) and flexible rubber connectors must be used in the installation of units to meet noise and vibration prevention requirements.
- 3) Insert a M10 expansion bolt into the hole. Drive a nail into the bolt. Refer to the profile dimensions drawing of the indoor unit for the distance between the holes. Refer to Figure 1 for the installation of the expansion bolt, as Figure 1-1-1 shows.

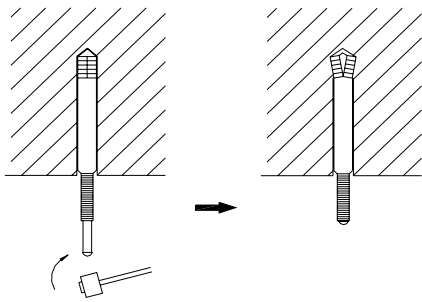

Figure 1-1-1

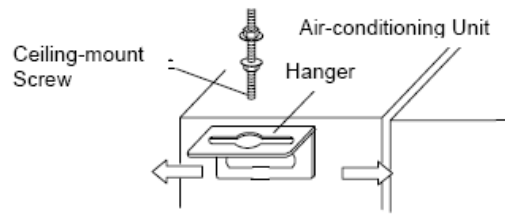

Figure 1-1-2

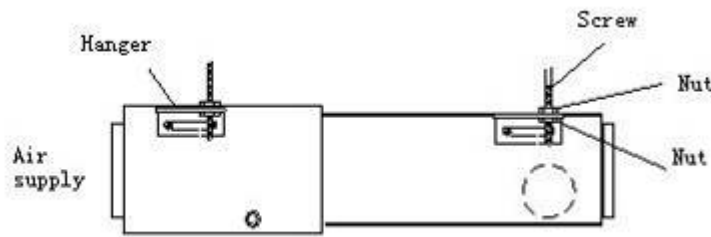

Figure 1-1-3

- 4) Install the hanger onto the indoor unit as Figure 1-1-2 and Figure 1-1-3 shows.
- 5) Install the indoor unit at the ceiling as Figure 1-1-5 shows.

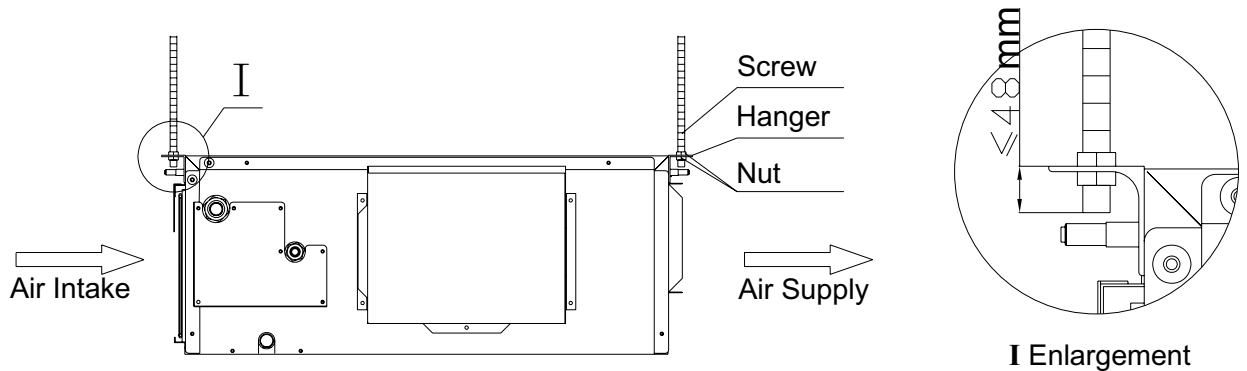

Figure 1-1-5

- 6) Precautions for unfavorable installation:
 - ◆ The preparation of all pipes (connecting pipes and drainage pipes) and cables (connecting lines of wire controller, indoor unit and outdoor unit) must be ready before the installation, so as to achieve smooth installation.
 - ◆ Drill an opening on the ceiling. Maybe it is required to support the ceiling to ensure the evenness of it and avoid the vibration of it. Consult with the user or a construction company for details.
 - ◆ In case the strength of ceiling is not enough, use angle iron sections to set up a beam support. Place the unit at the beam and fix it.

- 7) Level detection of indoor unit

After installation of indoor unit, level detection for the complete unit must be done to ensure levelness, as shown in Fig. 1-1-6.

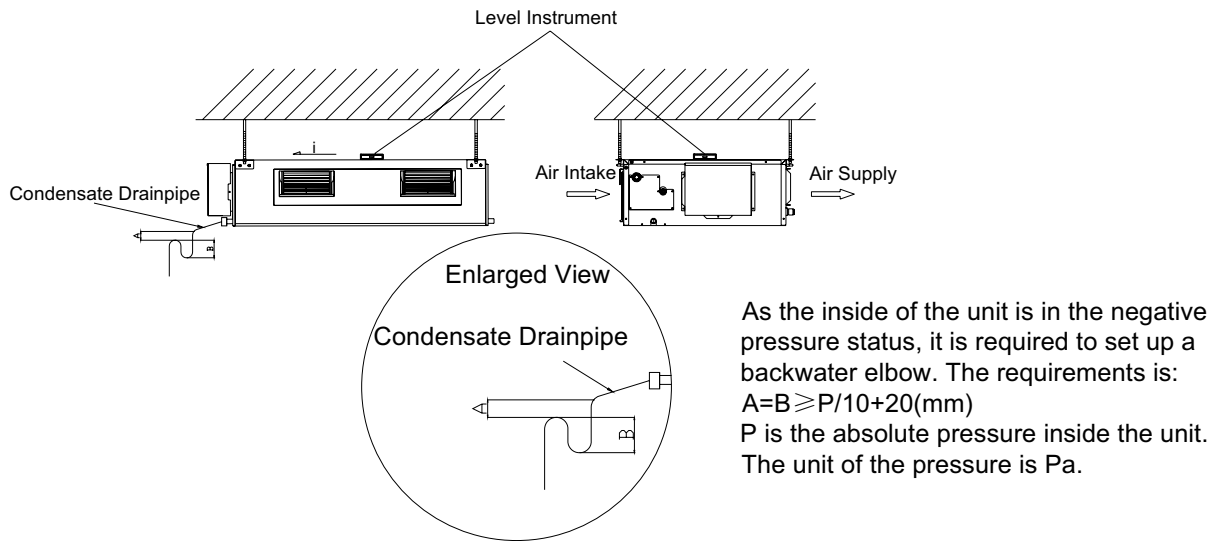

Figure 1-1-6

1.1.4 Dimension Data

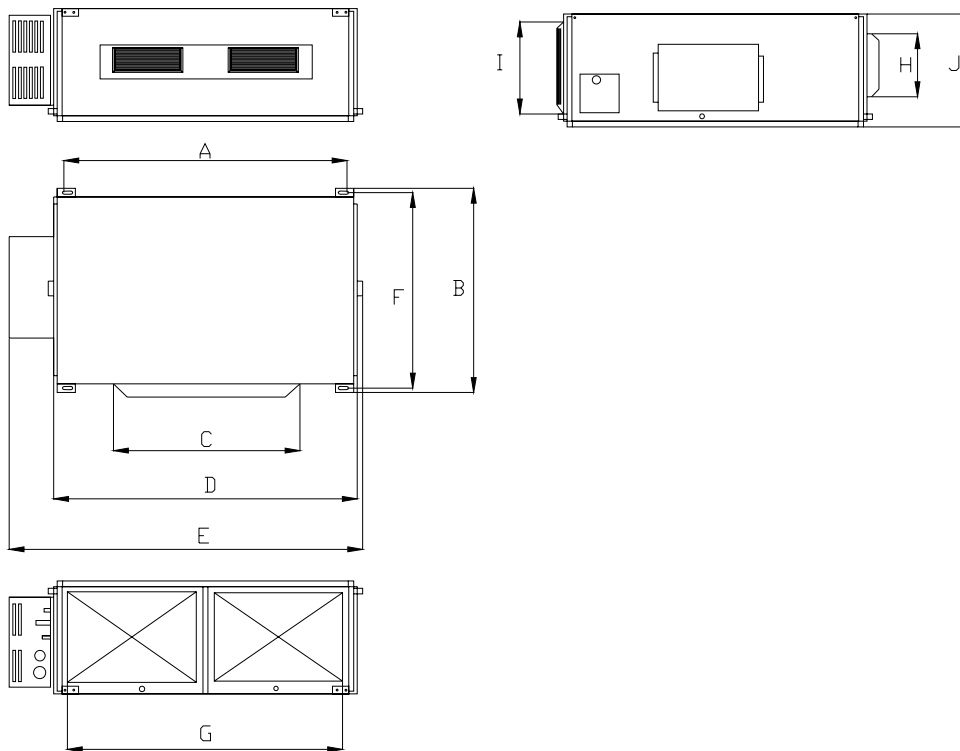

Figure 1-1-7

Unit: mm

Model	A	B	C	D	E	F	G	H	I	J
GFH09K3BI	856	571	515	790	913	680	750	100	172	220
GFH12K3BI										
GFH18K3BI	932	627	738	894	1012	736	738	125	207	266
GFH24K3BI	1101	395	820	1159	1207	504	1002	160	235	265
GFH36K3BI	1011	635	820	1115	1251	744	980	160	231	290
GFH42K3BI										
GFH48K3BI										
GFH60K3BI	1015	679	820	1115	1251	788	980	160	261	330

List of Accessories for Installation of Indoor Unit

Designation and shape	Qty	Description
Operation and installation instructions	1	
Heat insulating material for large connector	1	For air pipe connector of indoor unit
Heat insulating material for small connector	1	For refrigerant pipe connector of indoor unit
Heat insulation material for drain pipe	2	For packing condensate pipe and rubber plug
Nut with washer M8	8	For fixing the hanging hook
Nut with washer M10	4	Four sets, for hoisting the unit on the ceiling
Nut and spring washer	4	
Hanging hook	4	For hoisting the unit on the ceiling
Wire binding tie	4or 8	4 for a two-horsepower unit, 8 for other unit.
Wire controller	1	
Remote controller	1	
Battery	2	
Bellow	0, 2 or 4	0 for a 2-powerhorse unit, 2 for a 2.5–3 horsepower unit, 4 for a 4–5 horsepower unit.
Power cable	1–2	2 for a 4–5 horsepower unit and 1 for other unit.
Connecting cable	2–3	3 for a 4–5 horsepower unit and 2 for other unit.

1.1.5 Installation Clearance Data

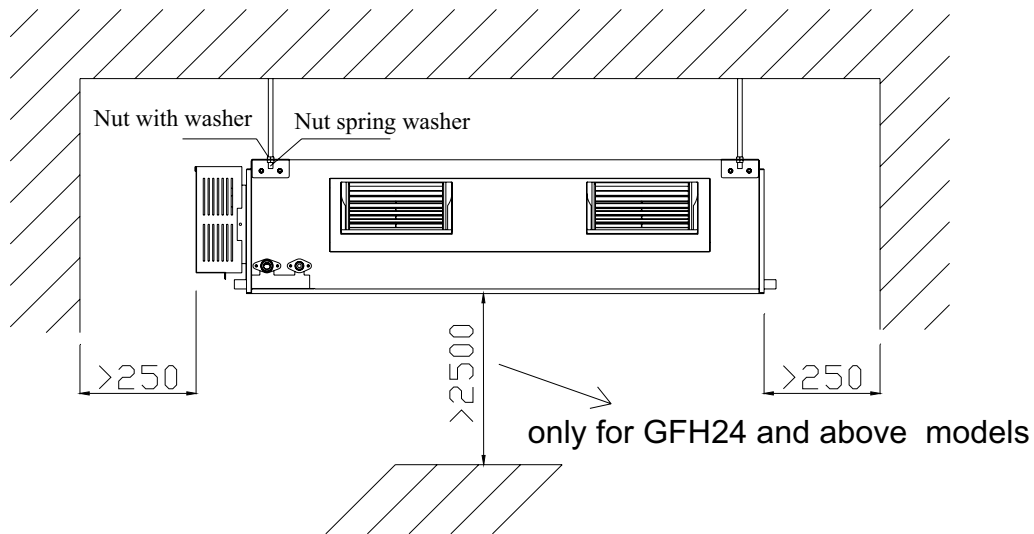

Figure 1-1-8

1.1.6 Drain Piping Work

1) Installation of Drainage Pipeline

- ◆ A drainage outlet is located at both the left and right sides of the indoor unit. After selecting one drainage outlet, the other outlet shall be blocked by rubber plug. Bundle the blocked outlet with string to avoid leakage, and also use thermal insulation materials to wrap the blocked outlet.
- ◆ When shipped out from factory, both the Drainage outlets are blocked by rubber plugs.
- ◆ When connecting the drainage pipe with the unit, do not apply excessive force to the pipeline at the side of the unit. The fixing position of the pipeline shall be near the unit.
- ◆ Purchase general-purpose hard PVC pipe locally to be used as the drainage pipeline. When carrying out connection, place the end of the PVC pipeline into the drainage hole. Use flexible drainage tube and tighten it with thread loop. Never use adhesive to connect the drainage hole and the flexible drainage tube. (As shown in Figure 1-1-9)
- ◆ When the laid drainage pipe is used for multiple units, the common pipe shall be about 100mm lower than the drainage outlet of each set of unit. A pipe with thicker wall shall be used for such purpose.

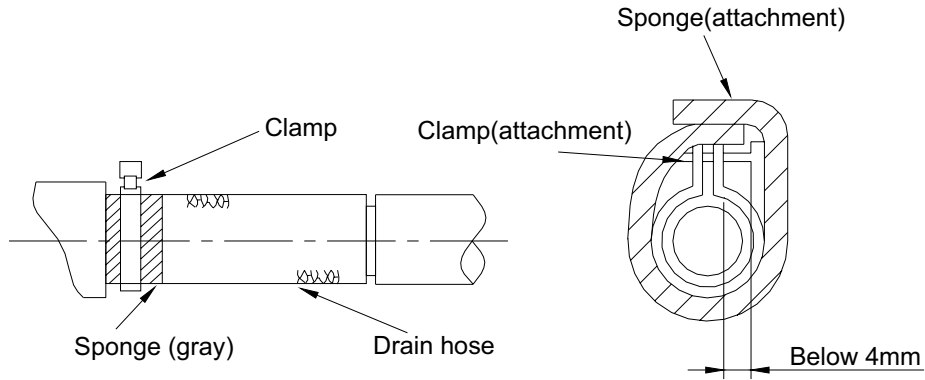

Figure 1-1-9

2) Testing of Drainage System

- ◆ After the electrical installation is completed, carry out the testing of the drainage system.
- ◆ During the test, check if the water correctly flows through the pipelines. Carefully observe the joints to ensure that there is no leakage. If the unit is to be installed in a new house, carry out testing before decorating the ceiling.

3) Matters of Attention

- ◆ The joint of Drainage Pipeline must not have leakage.
- ◆ The Drainage Pipeline shall be installed with an inclining angel of $5\sim 10^\circ$, so as to facilitate the drainage of condensate. The joints of the Drainage Pipeline must be covered by thermal insulation materials to avoid generation of exterior condensate. (As shown in Figure 1-1-10)

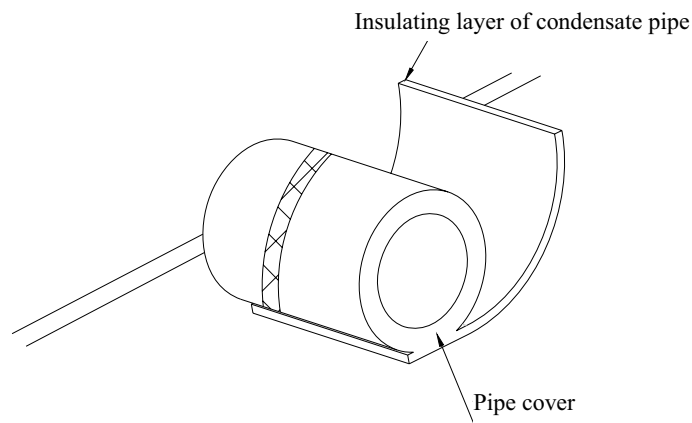

Figure 1-1-10

1.1.7 Installation of air pipes and openings

Caution:

- ◆ The air supply pipe, the air intake pipe and the fresh air pipe must be covered with a layer of thermal insulation, so as to avoid thermal leakage and condensation. Firstly apply liquid nail on the pipes, then attach the thermal insulation cotton with a layer of tinfoil. Use the liquid nail cover to fix it. Lastly use tinfoil adhesive tape to carefully seal the joints; other good thermal insulation materials can also be used.
- ◆ The air supply pipes and the air intake pipes shall be fixed to the prefabricated boards of the ceiling by using

iron supports. The joints of the pipes must be sealed by glue so as to avoid leakage.

- ◆ The design and installation of air pipes must be in conformity with the relevant state engineering criteria.
- ◆ The edge of the air intake pipe must be at least 150mm away from the wall. The air intake must be covered with filter.
- ◆ Silencing and shock absorption shall be considered in the design and installation of the air pipes. Additionally, the noise source must be far away from where people stay. The air intake shall not be located above the place where users stay (offices and rest places, etc.).

1) Installation of air supply duct

- ◆ Installation of rectangular air duct, as shown in Figure 1-1-11

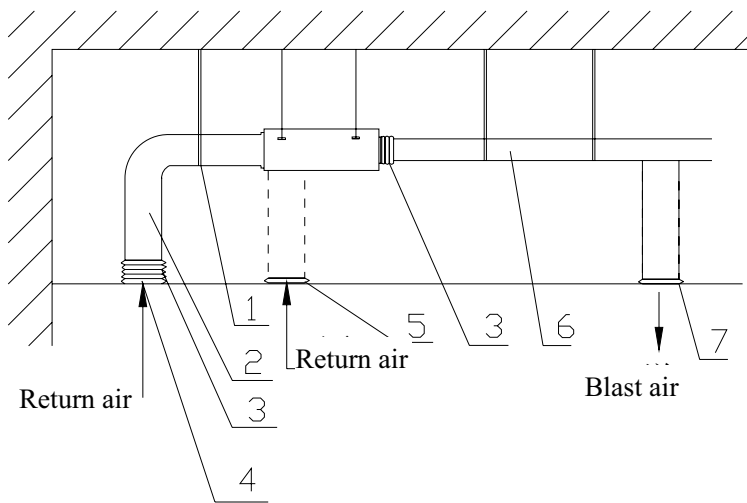

Figure 1-1-11

No.	Designation	No.	Designation
1	Hanger rod	5	Filter screen
2	Return duct	6	Main air supply duct
3	Canvas duct	7	Air outlet
4	Return air inlet		

- ◆ Installation of circular duct, as shown in Figure 1-1-12

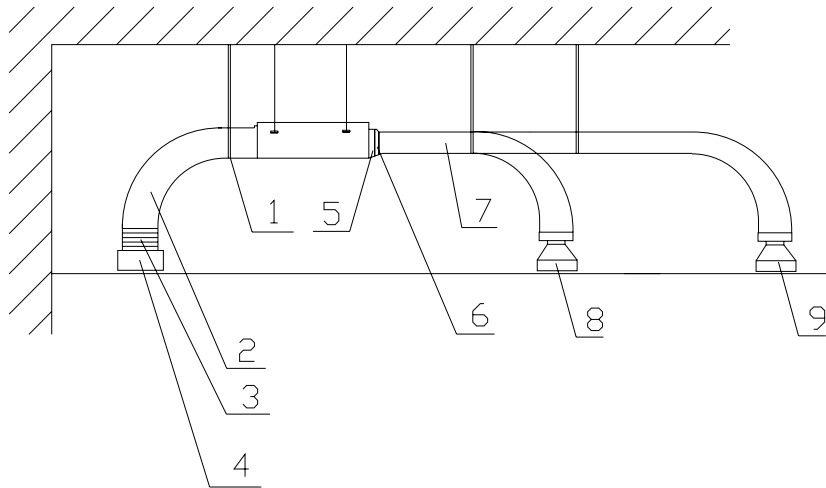

Figure 1-1-12

No.	Designation	No.	Designation
1	Hanger rod	6	Transition duct
2	Air return duct	7	Air blast duct
3	Canvas duct	8	Air diffuser
4	Return air shutter	9	Connector of air diffuser
5	Air outlet		

Note:

The above two diagrams show how back return air inlets are installed. Lower return air inlets shall be used according to actual installation demands. The installation method is similar to the back return air inlets. Among all air outlets, at least one keeps open. If circular duct is in use, air shall be supplied to rooms through circular flexible insulating duct. Air supply duct and return duct shall be heat insulated.

2) Installation of fresh air duct (only limited to excessive pressure units with refrigerating output over 6000W)

- ◆ The fresh air battle, as shown in Figure 1-1-13(a), must be removed for mounting the fresh air duct. If the fresh air duct is not in use, gaps around the battle shall be sealed by sponge.
- ◆ Circular flanges are mounted for convenient connection of the fresh air duct, as shown in Figure 1-1-14(b)
- ◆ Ducts and circular flanges must be sealed and insulated sufficiently.
- ◆ Fresh air must be filtered air.

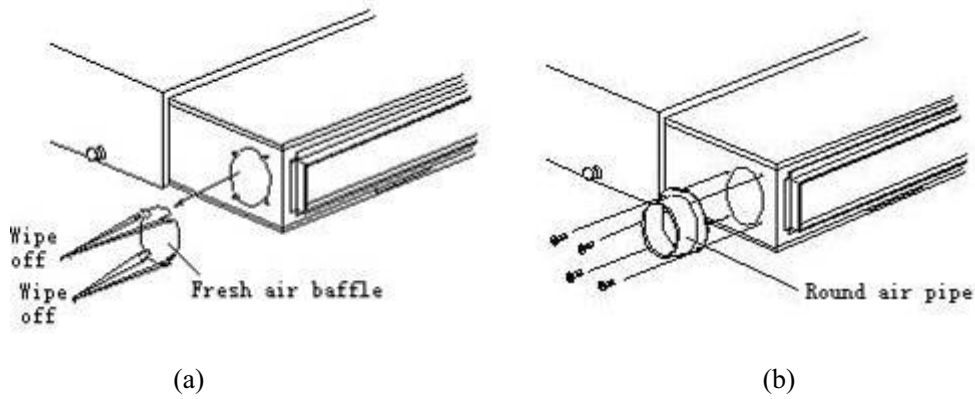

Figure 1-1-13

3) Installation of air return duct

- ◆ Square flanges at ex-factory shall be defaulted to installation at the back and the air return cover plate shall be mounted at the lower, as shown in figure 1-1-14.

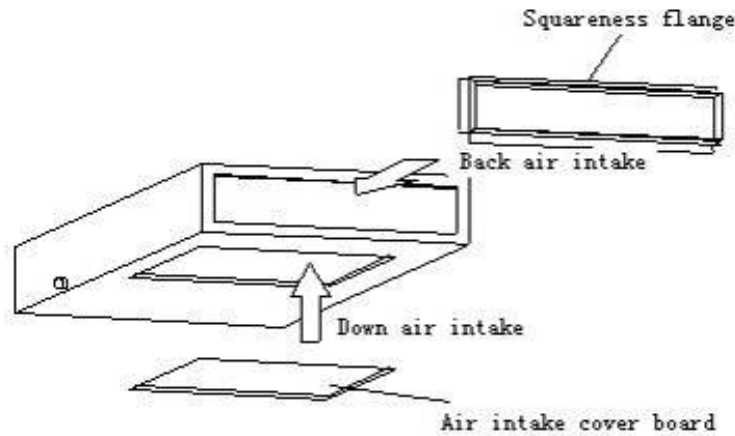
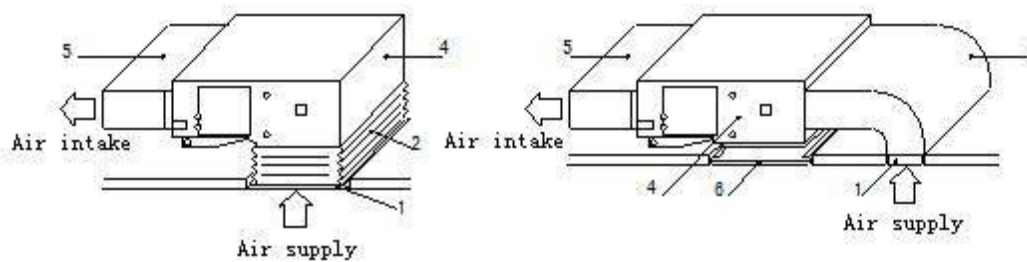

Figure 1-1-14

- ◆ If lower air return is demanded, the square flange and the air return cover plate should be exchanged in their respective position.
- ◆ The air return duct shall be connected to the air return inlet on the indoor unit with rivets, and the other end of the air return duct is connected to an air return window. To freely adjust the height, a section of canvas duct can be fabricated and reinforced by 8 # iron wires in the folding shape. A proper installation method shall be selected by taking into overall consideration of building and maintenance conditions.



No.	Designation	No.	Designation
1	Air return window	4	Indoor unit
2	canvas duct	5	Air supply duct
3	Air return duct	6	Check grating

Figure 1-1-15

4) Installation of circular air supply outlet

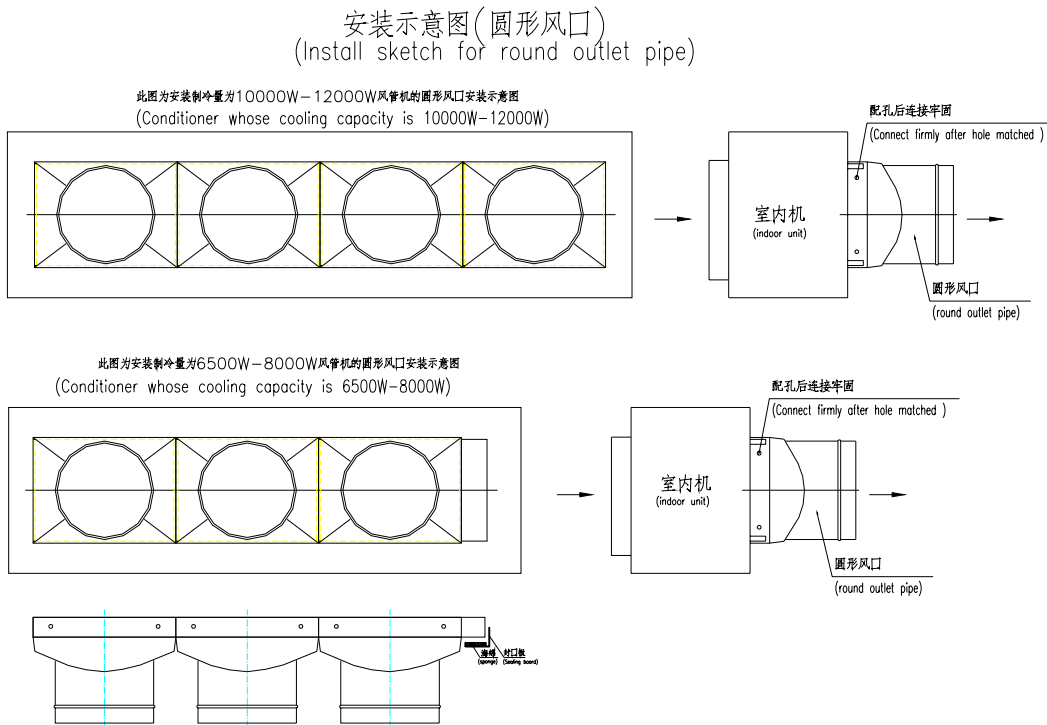

Figure 1-1-16

1.2 Installation of Ceiling Type

1.2.1 Before Installation

- ◆ When the machine arrives, please check if any damage due to transport is existent. If any hurt is found on the surface or inside, please declare to the transport company or the manufacturer in writing.
- ◆ When the machine arrives, please check if any damage due to transport is existent. If any hurt is found on the surface or inside, please declare to the transport company or the manufacturer in writing.
- ◆ Correct handling route and method shall be decided to prevent damage to the unit. For protecting the unit and ensuring its safety, carrying the unit with its package is recommended. If such carrying method is difficult under particular conditions, the canton shall not be removed to avoid looseness or falling during handling.
- ◆ Confirm the foundation is secure. When the unit is installed on the metal part of a building, electrical insulation must be in compliance with relevant standards.
- ◆ Confirm the installation position is away from storage zone of inflammable and explosive substances, or otherwise leakage of inflammable and explosive substances may lead to explosion or a fire.

1.2.2 Installation Site

- ◆ Such a place where cool air can be distributed throughout the room.
- ◆ Such a place where is condensation water is easily drained out.
- ◆ Such a place that can handle the weight of indoor unit.
- ◆ Such a place which has easy access for maintenance.
- ◆ Such a place where is permitting easy connection with the outdoor unit.
- ◆ Such a place where is 1m or more away from other electric appliances such as television, audio device, etc.
- ◆ Avoid a location where there is heat source, high humidity or inflammable gas.
- ◆ Do not use the unit in the immediate surroundings of a laundry, a bath, a shower or a swimming pool.
- ◆ Be sure that the installation conforms to the installation dimension diagram.
- ◆ The space around the unit is adequate for ventilation

1.2.3 Caution for Installation

- ◆ Adjust the distance from the unit to the ceiling slab beforehand (Refer to Figure 1-2-1).
- ◆ Fix the hanger bracket to the suspension bolt (Refer to Figure 1-2-2).
- ◆ Make sure that extended suspension bolt from the ceiling stays inside the arrowed position. Readjust the hanger bracket when it is outside the arrowed position. (Refer to Figure 1-2-3)
- ◆ Suspension bolt stays inside the cap of indoor unit .Never remove the cap. Lift the unit and slide forward unit the dent. (Refer to Figure 1-2-4)
- ◆ Screw tightly both hanger bracket setting bolts (M8) (Refer to Figure 1-2-2)
- ◆ Screw tightly both hanger bracket fixing bolts (M6) to prevent the movement of the indoor unit. (Refer to Figure 1-2-2)
- ◆ Adjust the height by turning the nut with a spanner. Insert the spanner from the hanger bracket opening. (Refer to Figure 1-2-5)

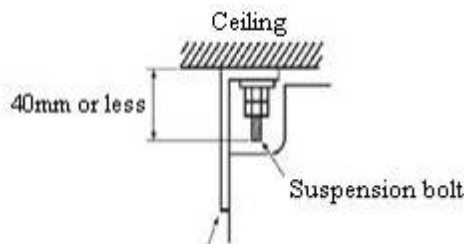

Hanger bracket Figure 1-2-1

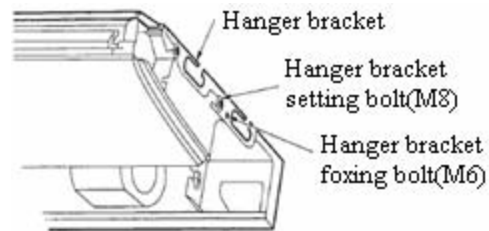

Figure 1-2-2

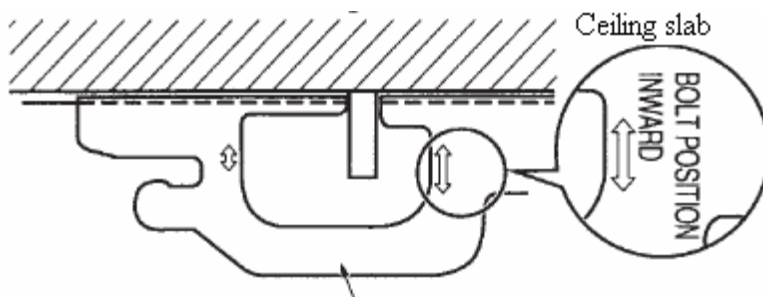

Figure 1-2-3 Hanger bracket

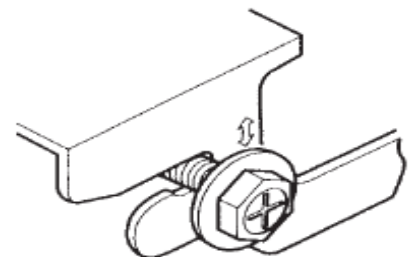

Figure 1-2-4

In case of hanging:

It is possible to install using inward facing hanger bracket by not removing the brackets from the indoor unit. (Refer to Figure 1-2-6) Be sure to use only the specified accessories and parts for installation work.

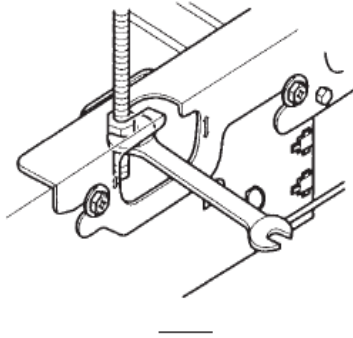

Figure 1-2-5

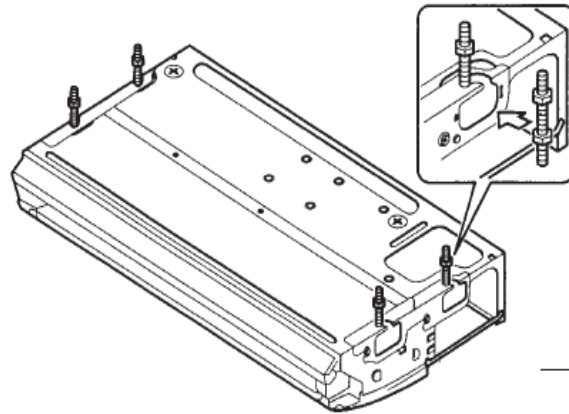

Figure 1-2-6

1.2.4 Dimension Data

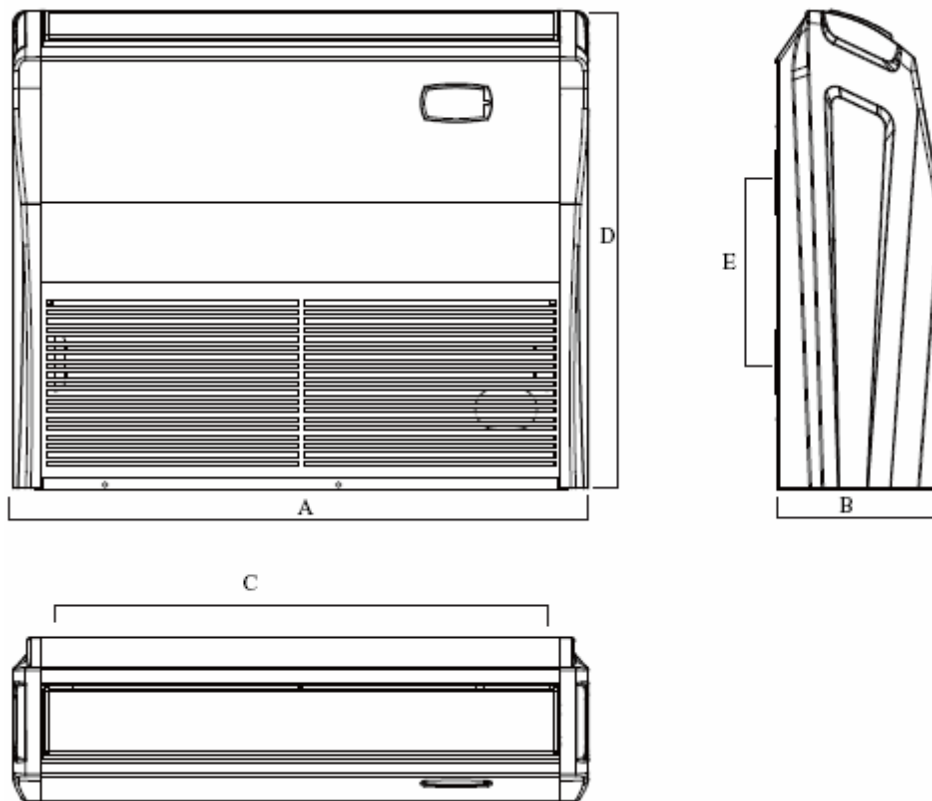

Figure 1-2-7

Unit: mm

Model	A	B	C	D	E
GTH09K3BI	836	238	745	695	260
GTH12K3BI					

GTH18K3BI					
GTH24K3BI	1300	188	1202	600	260
GTH36K3BI	1590	238	1491	695	260
GTH42K3BI					
GTH48K3BI					

1.2.5 Installation Clearance Data

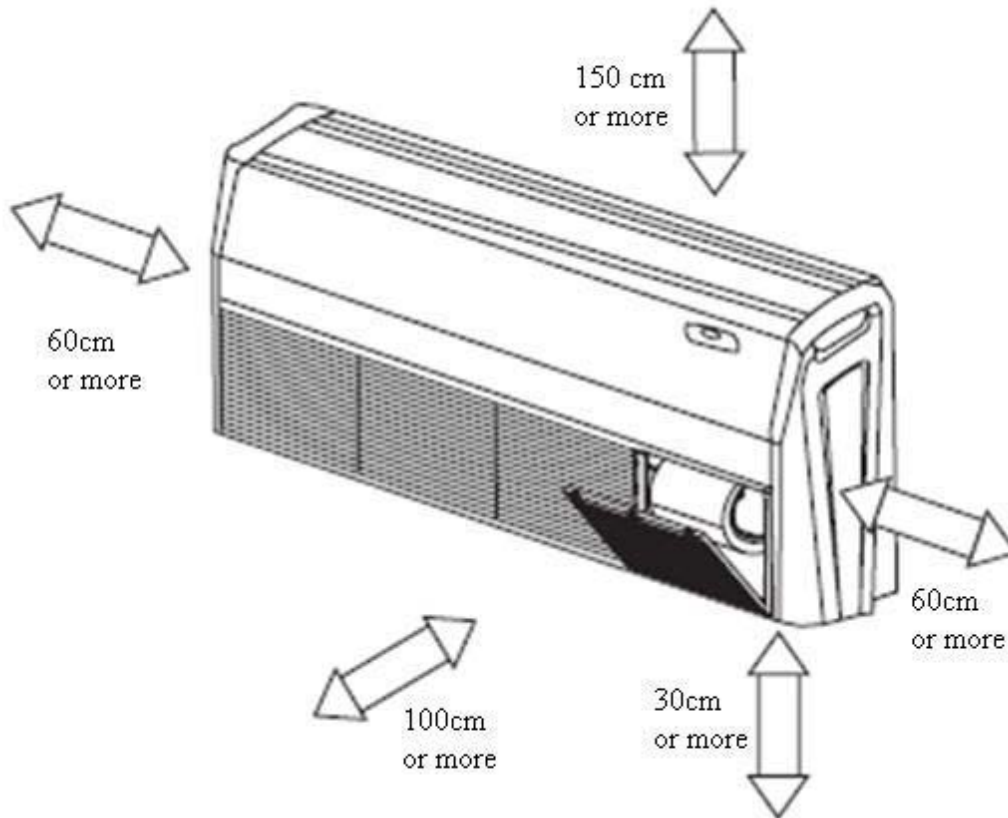

Figure 1-2-8

1.2.6 Drain Piping Work

1) Installation of Drainage Pipeline

- ◆ A Drainage outlet is located at both the left and right sides of the indoor unit. After selecting one Drainage outlet, the other outlet shall be blocked by rubber plug. Bundle the blocked outlet with string to avoid leakage, and also use thermal insulation materials to wrap the blocked outlet.
- ◆ When shipped out from factory, both the Drainage outlets are blocked by rubber plugs.
- ◆ When connecting the drainage pipe with the unit, do not apply excessive force to the pipeline at the side of the unit. The fixing position of the pipeline shall be near the unit.
- ◆ Purchase general-purpose hard PVC pipe locally to be used as the drainage pipeline. When carrying out connection, place the end of the PVC pipeline into the drainage hole. Use flexible drainage tube and tighten it with thread loop. Never use adhesive to connect the drainage hole and the flexible drainage tube. (As shown in Figure 1-2-9)
- ◆ When the laid drainage pipe is used for multiple units, the common pipe shall be about 100mm lower than

the drainage outlet of each set of unit. A pipe with thicker wall shall be used for such purpose.

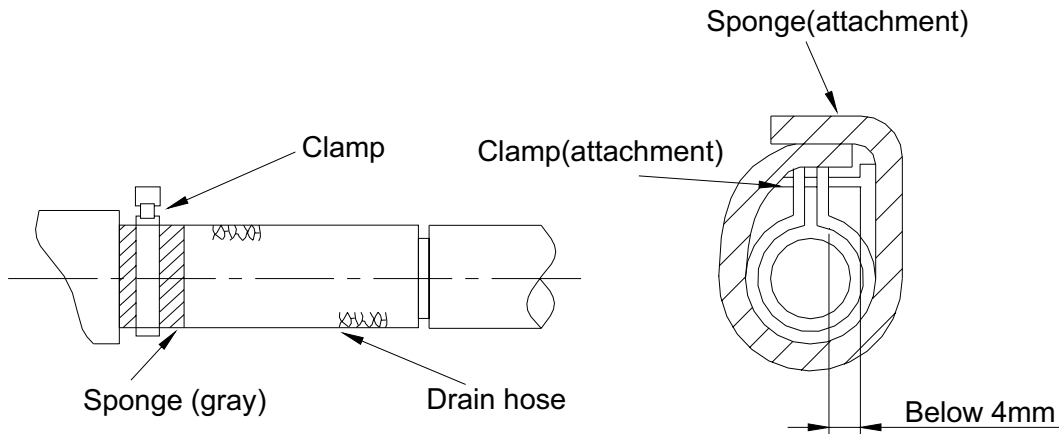

Figure 1-2-9

2) Testing of Drainage System

- ◆ After the electrical installation is completed, carry out the testing of the drainage system.
- ◆ During the test, check if the water correctly flows through the pipelines. Carefully observe the joints to ensure that there is no leakage. If the unit is to be installed in a new house, carry out testing before decorating the ceiling.

3) Matters of Attention

- ◆ The drain pipe outlet direction can be chosen from either the right rear or right.

The diameter of the drain pipe should be equal to or greater than the diameter of the connecting pipe. (Vinyl tube; pipe size: 20mm; outer dimension: 26mm)

Keep the drain pipe short and incline downwards at a gradient of at least 1/100 to prevent air pockets. (Refer to Figure 1-2-10)

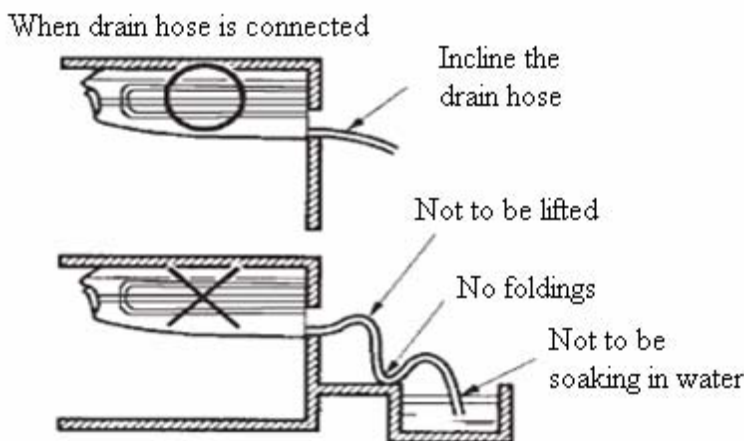

Figure 1-2-10

- ◆ No folding of drain hose inside the indoor unit. (Refer to Figure 1-2-11)
- ◆ Confirm that smooth drainage is achieved after the piping work. Pour 600 cc of water into the drain pan from the air outlet for confirming drainage. (Refer to Figure 1-2-12)

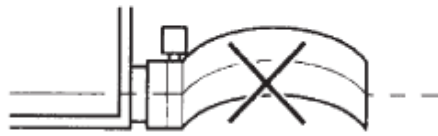

Figure 1-2-11

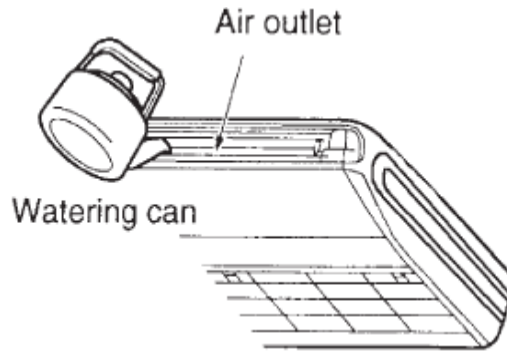

Figure 1-2-12

1.3 Installation of Cassette Type

1.3.1 Before Installation

- ◆ When the machine arrives, please check if any damage due to transport is existent. If any hurt is found on the surface or inside, please declare to the transport company or the manufacturer in writing.
- ◆ Upon receipt of the machine, the unit and accessories shall be checked in accordance with the packing list. Before acceptance, it must be confirmed that the model is correct and the unit is in good shape and specification and quantity of accessories are right.
- ◆ Correct handling route and method shall be decided to prevent damage to the unit. For protecting the unit and ensuring its safety, carrying the unit with its package is recommended. If such carrying method is difficult under particular conditions, the carton shall not be removed to avoid looseness or falling during handling.
- ◆ Confirm the foundation is secure. When the unit is installed on the metal part of a building, electrical insulation must be in compliance with relevant standards.
- ◆ Confirm the installation position is away from storage zone of inflammable and explosive substances, or otherwise leakage of inflammable and explosive substances may lead to explosion or a fire.

1.3.2 Installation Site

- ◆ Obstruct should put away from the intake or outlet vent of the indoor unit so that the airflow can be blown though all the room.
- ◆ Make sure that the installation had accord with the requirement of the schematic diagram of installation spaces.
- ◆ Select the place where can stand 4 times of the weight of the indoor unit and would not increase the operating noise and oscillate.
- ◆ The horizontally of the installation place should be guaranteed.
- ◆ Select the place where is easy to drain out the condensate water, and connect with outdoor unit.
- ◆ Make sure that there are enough space for care and maintenance. Make sure that the weight between the indoor unit and ground is above 2300mm.
- ◆ When installing the steeve bolt, check if the install place can stand the weight 4 times of the unit's. If not, reinforce before installation. (Refer to the install cardboard and find where should be reinforced) The appliance shall not be installed in laundry.

Cautions:

There will be lots of lampblack and dust stick on the acentric, heat exchanger and water pump in dining room and kitchen, which would reduce the capacity of heat exchanger, lead water leakage and abnormal operation of the water pump.

The following treatment should be taken under this circumstance:

- ◆ Ensure that the smoke trap above cooker has enough capacity to obviate lampblack to prevent the indraft of the lampblack by the air conditioner.
- ◆ Keep the air conditioner far from the kitchen so that the lampblack would not be indraft by the air conditioner.

1.3.3 Caution for Installation

1) Important notice:

- ◆ To guarantee the good performance, the unit must be installed by professional personnel according with this instruction.
- ◆ Please contact the local Gree special nominated repair department before installation. Any malfunction caused by the unit that is installed by the department that is not special nominated by Gree would not deal with on time by the inconvenience of the business contact.

2) Dimension of ceiling opening and location of the hoisting screw (M10)

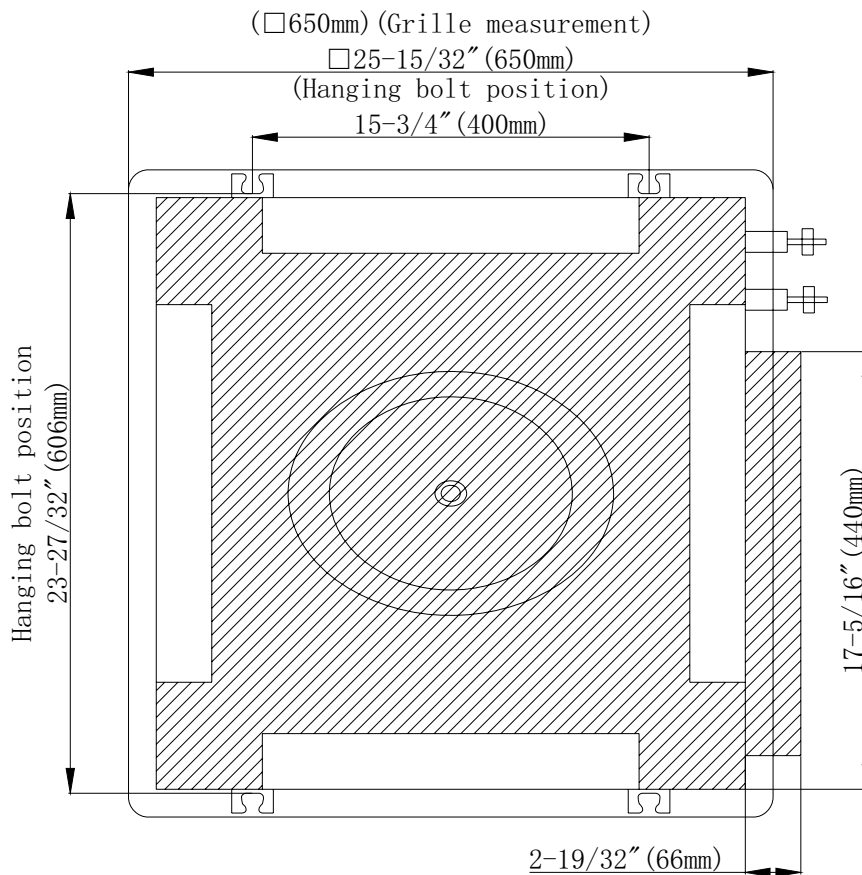

GKH12K3BI/GKH18K3BI

Figure 1-3-1

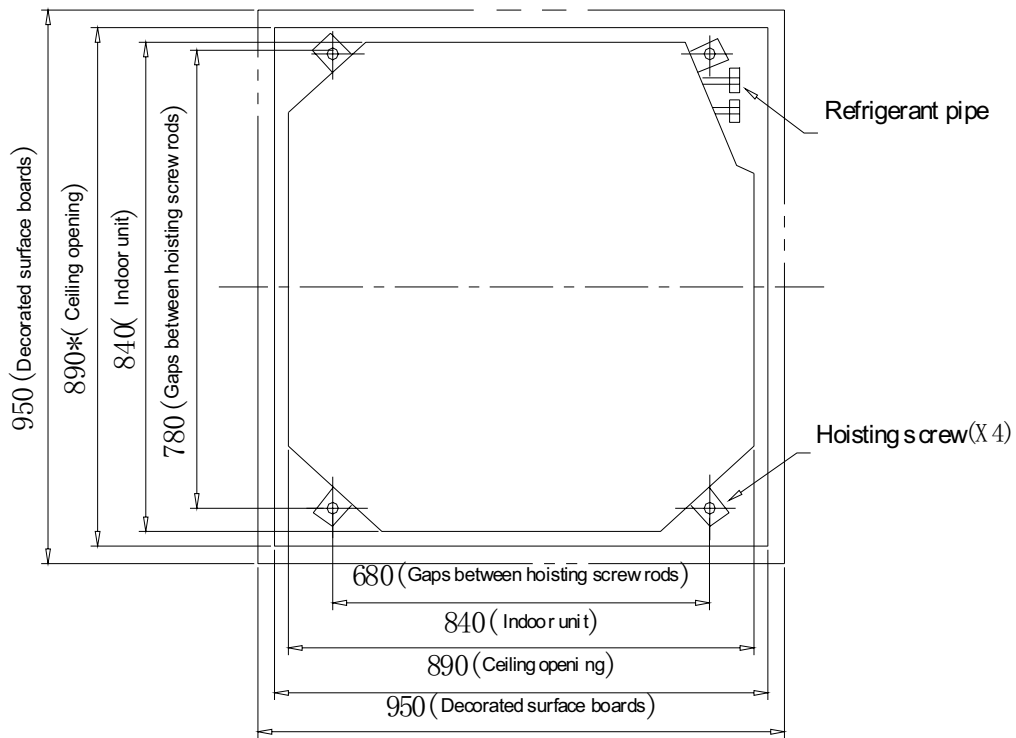

GKH24K3BI/GKH36K3BI/GKH42K3BI/GKH48K3BI

Figure 1-3-2

The drilling of holes in the ceiling must be done by the professional personnel.

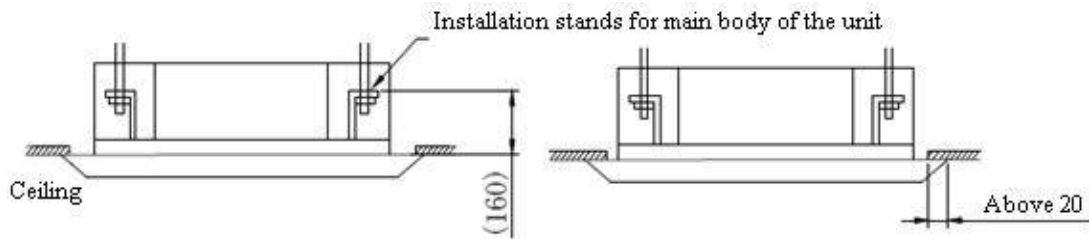

Figure 1-3-3

Cautions:

The dimension for the ceiling openings with * marks can be as large as 910mm. But the overlapping sections of the ceiling and the decorated surface boards should be maintained at no less than 20mm.

3) Main body of hoisting air conditioner

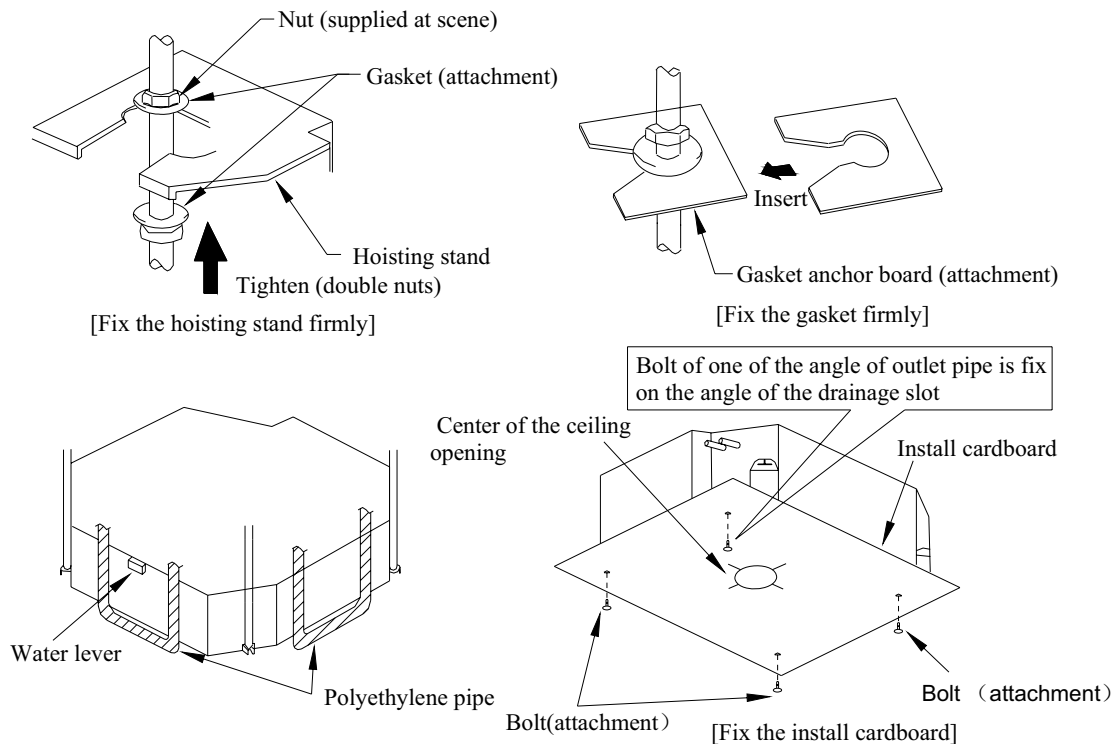

Figure 1-3-4

◆ The primary step for install the indoor unit.

When attach the hoisting stand on hoisting screw, do use nut and gasket individually at the upper and lower of the hoisting stand to fix it. The use of gasket anchor board can prevent gasket break off.

◆ Use install cardboard

Please refer to the install cardboard about the dimension of ceiling opening.

The central mark of the ceiling opening is marked on the install cardboard.

Install the install cardboard on the unit by bolt (3 piece), and fix the angle of the drainage pipe at the outlet vent by bolt.

◆ Adjust the unit to the suitable install place.

◆ Check if the unit is horizontal.

Inner drainage pump and bobber switch are included in the indoor unit, check if 4 angle of every unit are horizontal by water lever. (If the unit is slant toward the opposite of the coagulate water flow, there may be malfunction of the bobber switch and lead water drop.)

◆ Backout the gasket anchor board used to prevent gasket break off and tighten the nut on it.

◆ Backout the install cardboard.

Cautions:

Please do tighten the nuts and bolts to prevent air conditioner break off.

1.3.4 Dimension Data

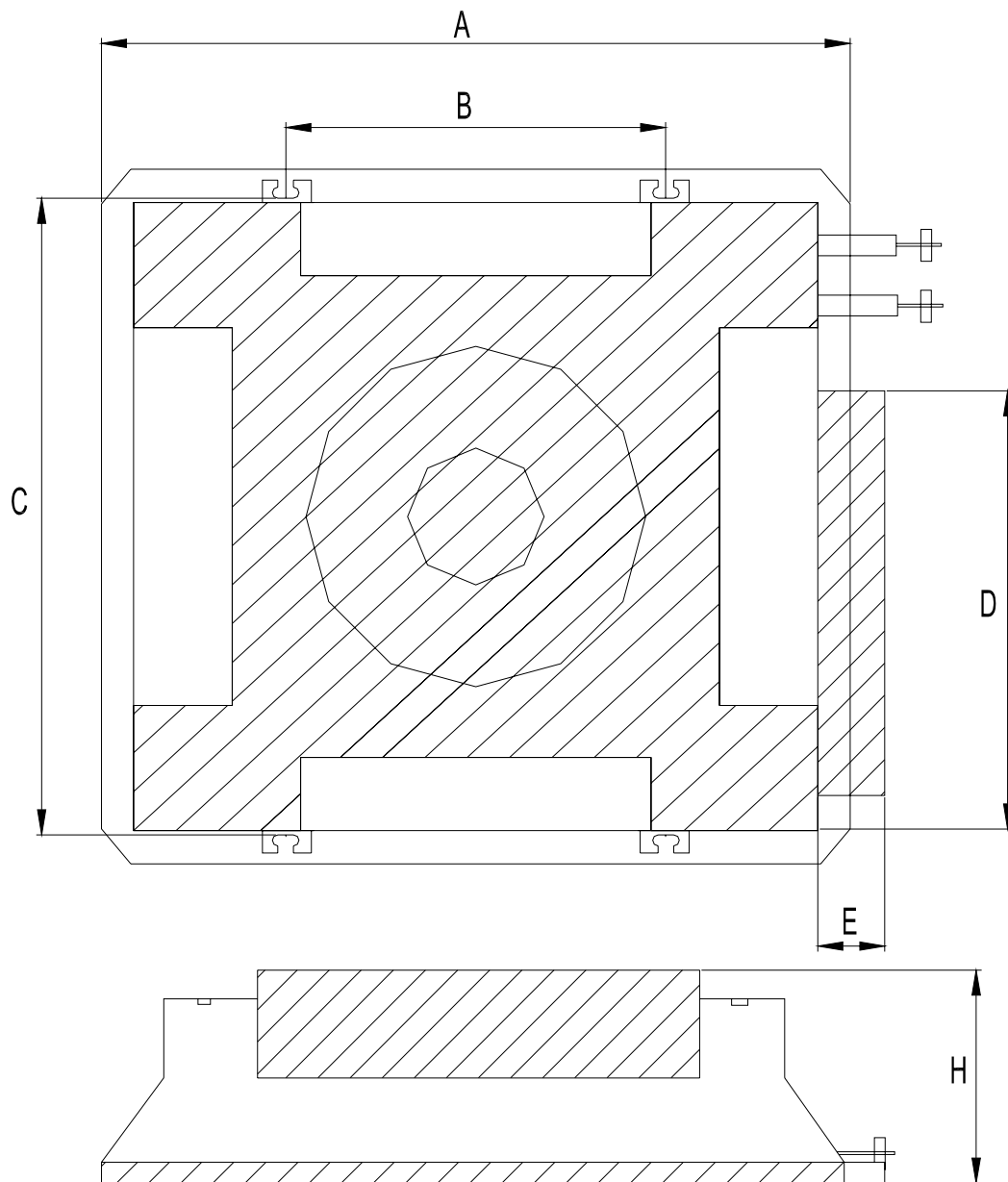

Figure 1-3-5

Model	H	A	B	C	D	E
GKH12K3BI	245	650	400	606	440	66
GKH18K3BI						
GKH24K3BI	275	950	680	840	720	76
GKH36K3BI	345	950	680	840	720	76
GKH42K3BI						
GKH48K3BI						

1.3.5 Installation Clearance Data

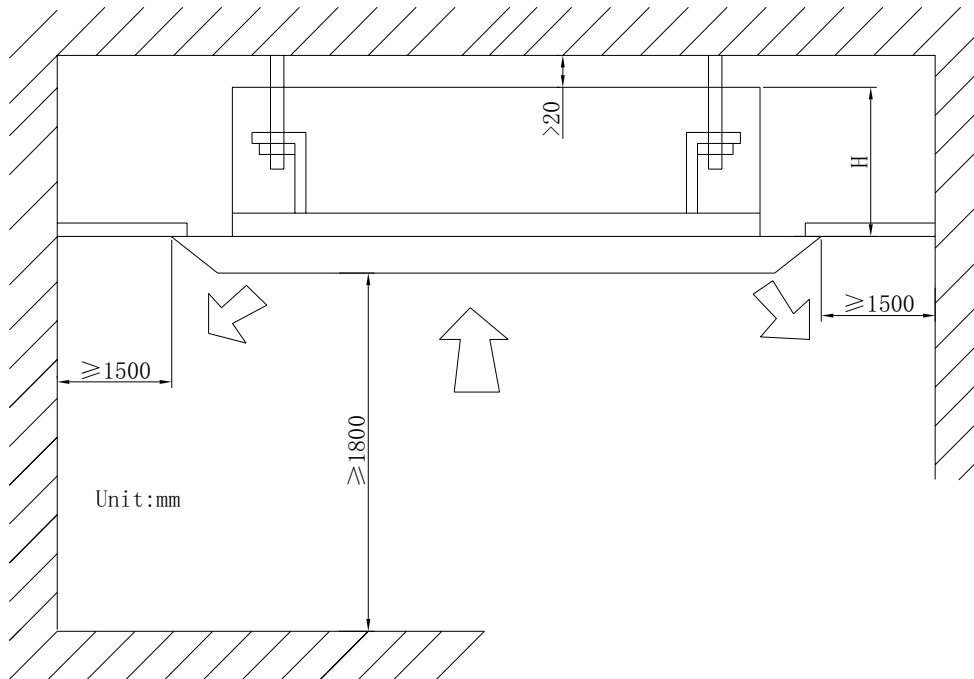

Figure 1-3-6

Models	H(mm)
GKH12K3BI GKH18K3BI	230
GKH24K3BI	260
GKH36K3BI GKH42K3BI GKH48K3BI	320

1.3.6 Drain Piping Work

1) Installation of Drainage Pipeline

- ◆ When connecting the drainage pipe with the unit, do not apply excessive force to the pipeline at the side of the unit. The fixing position of the pipeline shall be near the unit.
- ◆ Purchase general-purpose hard PVC pipe locally to be used as the drainage pipeline. When carrying out connection, place the end of the PVC pipeline into the drainage hole. Use flexible drainage tube and tighten it with thread loop. Never use adhesive to connect the drainage hole and the flexible drainage tube. (As shown in Figure 1-3-7)
- ◆ When the laid drainage pipe is used for multiple units, the common pipe shall be about 100mm lower than the drainage outlet of each set of unit. A pipe with thicker wall shall be used for such purpose.

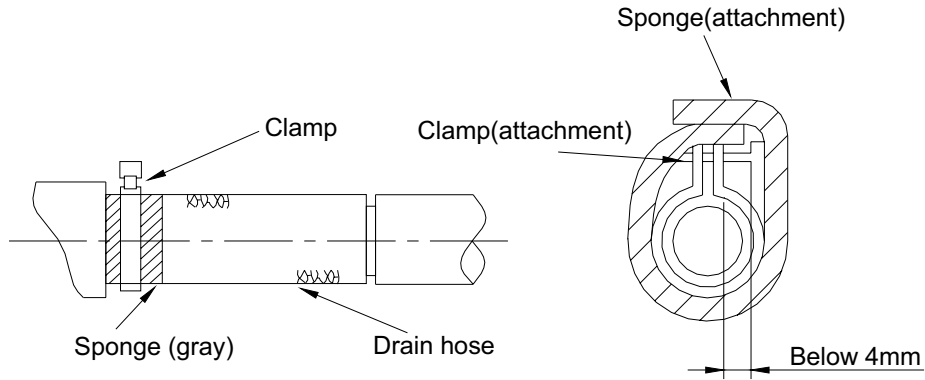

Figure 1-3-7

2) Testing of Drainage System

- ◆ After the electrical installation is completed, carry out the testing of the drainage system.
- ◆ During the test, check if the water correctly flows through the pipelines. Carefully observe the joints to ensure that there is no leakage. If the unit is to be installed in a new house, carry out testing before decorating the ceiling.

3) Matters of Attention

- ◆ The diameter of the drain hose should be equal or bigger than the connection pipe's. (The diameter of polythene pipe: Outer diameter 25mm Surface thickness $\geq 1.5\text{mm}$)
- ◆ Drain hose should be short and drooping gradient should at less 1/100 to prevent the formation of air bubble.
- ◆ If drain hose cannot has enough drooping gradient, drain raising pipe should be added.
- ◆ To prevent bent of the drain hose, the distance between hoisting stand should is 1 to 1.5m. (As shown in Figure 1-3-8)

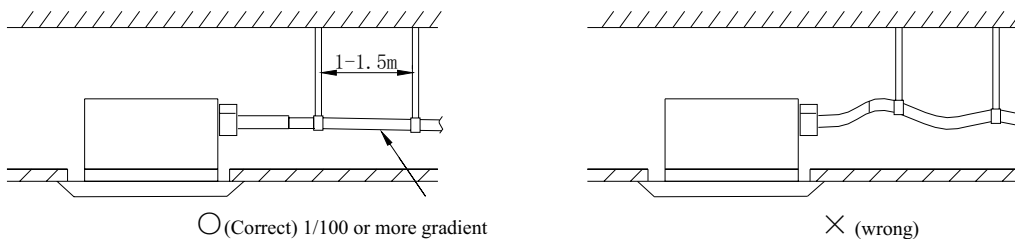

Figure 1-3-8

- ◆ The install height of the drain raising pipe should less than 280mm.
- ◆ The drain raising pipe should form a right angle with the unit, and distance to unit should not beyond 300mm. (As shown in Figure 1-3-9)

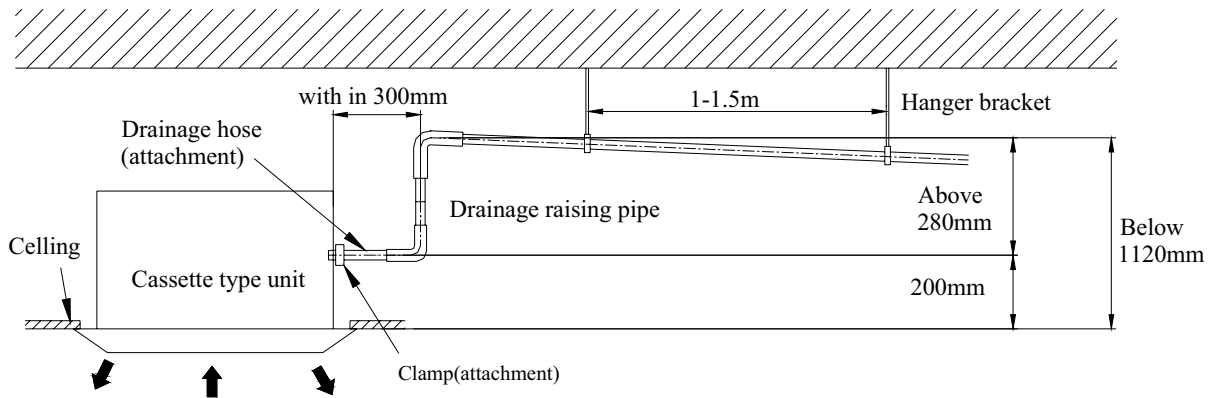

Figure 1-3-9

- ◆ The slant gradient of the attached drain hose should be within 75mm so that the drain hole doesn't has to endure the unnecessary outside force. (As shown in Figure 1-3-10)

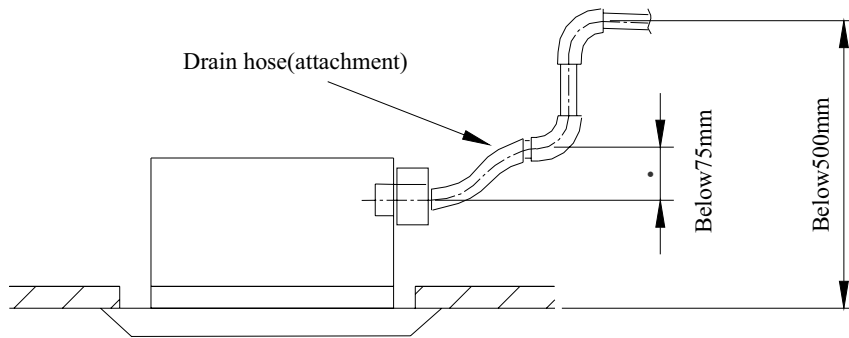
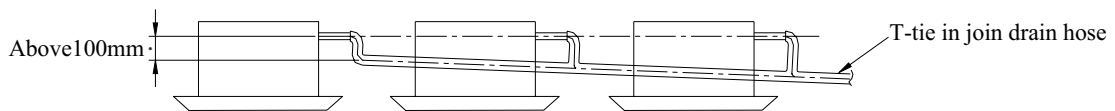

Figure 1-3-10

- ◆ Please install the drain hose according to the following process if several drain hoses join together. (As shown in Figure 1-3-11)



The specs of the selected join drain hose should fits the running capacity of the unit.

Figure 1-3-11

- ◆ Check the smoothness of drain after installation.
- ◆ Check the drain state by immiting 600cc water slowly from the outlet vent or test hole. (As shown in Figure 1-3-12)
- ◆ Check the drain in the state of refrigerating after installation of the electric circuit.

[Way of immiting]

Drain vent for repair use (plastic stopper is included) (drain the water in waterspout by this outlet vent)

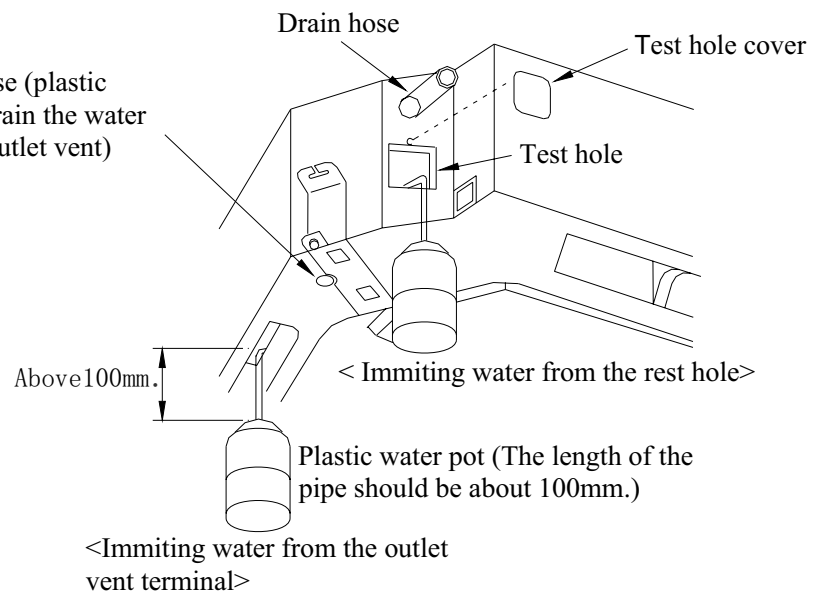

Figure 1-3-12

1.3.7 Installation of panel

- 1) Set the panel to the indoor unit body by matching the position of the swing flap motor of the decoration panel to the piping position of the panel to the piping position of the indoor unit as shown in Figure 1-3-13.

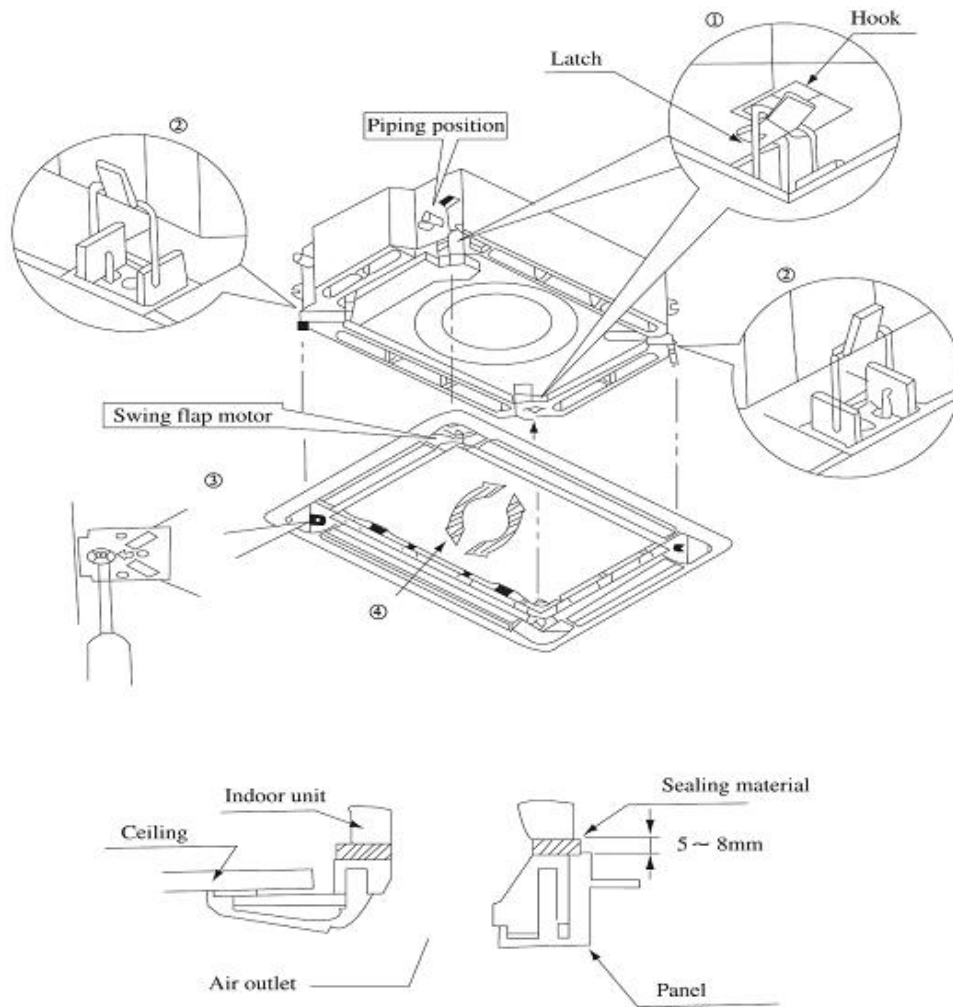

Figure 1-3-13

- ◆ Hang the latch, which is located on the opposite side of the swing flap motor on the panel, temporarily to the book of the indoor unit. (2 Positions)
- ◆ Temporarily hang the remaining 2 latches to the hooks on the sides of the indoor unit.(Be careful not to let the swing motor lead wire get caught in the sealing material.)
- ◆ Screw all 4 hexagon head screws located right beneath the latches in approximately 15mm.(Panel will rise)
- ◆ Adjust the panel by turning it to the arrowed direction in Fig.4 so that the ceiling opening is completely covered.
- ◆ Tighten the screws until the thickness of the sealing material between the panel and the indoor unit body is reduced to 5~8 mm.

2) Precautions:

- ◆ Improper screwing of the screws may cause the troubles shown in Figure 1-3-14.

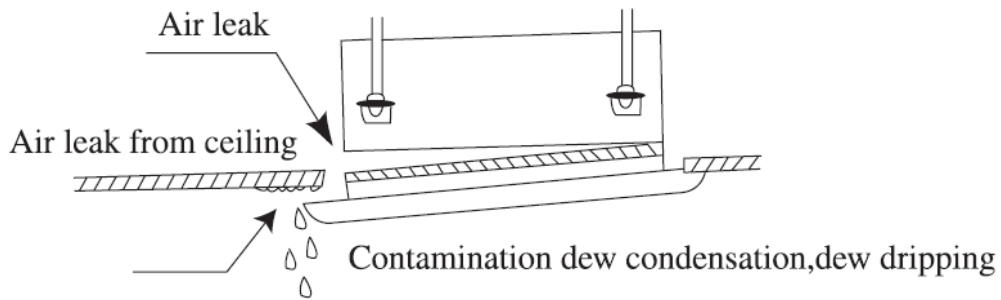

Figure 1-3-14

- ◆ If gap is still left between the ceiling and the panel after screwing the screws, readjust the height of the indoor unit body (Refer to Figure 1-3-15)

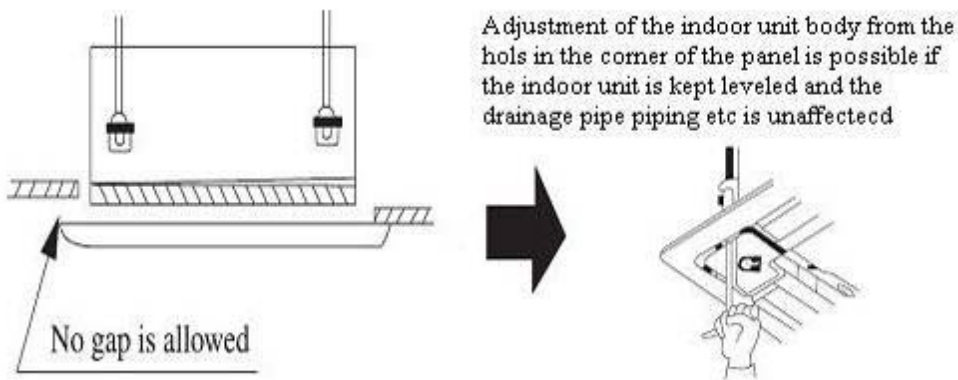

Figure 1-3-15

- ◆ After fixing be sure no gap left between the ceiling and the panel

3) Wiring of the decoration panel.

- ◆ Connect the joints for swing flap motor lead wire (at 2 places) installed on the panel (Refer to Figure 1-3-16)

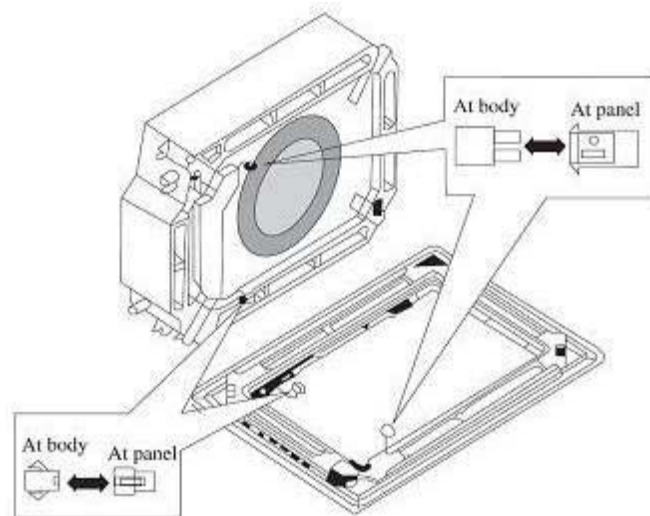

Figure 1-3-16

2 OUTDOOR UNIT INSTALLATION

2.1 Before Installation

- ◆ When the machine arrives, please check if any damage due to transport is existent. If any hurt is found on the surface or inside, please declare to the transport company or the manufacturer in writing.
- ◆ Upon receipt of the machine, the unit and accessories shall be checked in accordance with the packing list. Before acceptance, it must be confirmed that the model is correct and the unit is in good shape and specification and quantity of accessories are right.
- ◆ Correct handling route and method shall be decided to prevent damage to the unit. For protecting the unit and ensuring its safety, carrying the unit with its package is recommended. If such carrying method is difficult under particular conditions, the canton shall not be removed to avoid looseness or falling during handling.
- ◆ Confirm the foundation is secure. When the unit is installed on the metal part of a building, electrical insulation must be in compliance with relevant standards.
- ◆ Confirm the installation position is away from storage zone of inflammable and explosive substances, or otherwise leakage of inflammable and explosive substances may lead to explosion or a fire.

2.2 Installation Site

- ◆ To ensure the unit in proper function, selection of installation location must be in accordance with following principles:
- ◆ Outdoor unit shall be installed so that the air discharged by outdoor unit will not return and that sufficient space for repair shall be provided around the machine.
- ◆ The installation site must have good ventilation, so that the outdoor unit can take in and exhaust enough air. Ensure that there is no obstacle for the air intake and exhaust of the outdoor unit. If there is any obstacle blocking the air intake or exhaust, remove it.
- ◆ Place of installation shall be strong enough to support the weight of outdoor unit, and it shall be able to insulate noise and prevent vibration. Ensure that the wind and noise from the unit will not affect your neighbors.
- ◆ Avoid direct sunshine over the unit. It is better to set up a sun shield as the protection.
- ◆ Place of installation must be able to drain the rainwater and defrosting water.
- ◆ Place of installation must ensure the machine will not be buried under snow or subject to the influence of rubbish or oil fog.
- ◆ The installation site must be at a place where the air exhaust outlet does not face strong wind.
- ◆ Outdoor unit should be hoisted through indicated hoisting holes. During hoisting, special attention must be paid to the unit to prevent collision into its sheet metal parts to avoid rust.
- ◆ Rubber cushion or spring shock absorber shall be used for outdoor unit to avoid excessive noise and vibration.
- ◆ Rubber cushion or spring shock absorber shall be used for outdoor unit to avoid excessive noise and vibration.
- ◆ Only professional personnel are allowed for unit installation.

2.3 Caution for Installation

- ◆ Installation of outdoor unit shall not allow discharged air to return, and sufficient maintenance space shall be left around the machine.
- ◆ Installation position must be well-ventilated, enabling the machine to absorb and discharge enough air. Inlet and outlet must be free of obstruction. Any obstacle blocking air going in and out must be removed.
- ◆ When outdoor unit is mounted on the secure floor such as concrete, bolts and nuts in M10 can be used for fixing the unit. Uprightness or levelness of the machine must be ensured.
- ◆ Outdoor unit should be hoisted through indicated hoisting holes. During hoisting, special attention must be paid to the unit to prevent collision into its sheet metal parts to avoid rust.
- ◆ Rubber cushion or spring shock absorber shall be used for outdoor unit to avoid excessive noise and vibration. Uprightness or levelness must be ensured.
- ◆ In installation of drain pipe, the connector of the drain pipe shall be inserted into a drain hole on the chassis of the outdoor unit. And then a drain pipe shall be connected to the drain connector. (If the drain connector is used, installing height of the outdoor unit shall be at least 5cm).
- ◆ If pipe is put through wall, a wall pipe must be used.
- ◆ Installation dimension must be in line with requirements by the instructions. Outdoor unit must be fixed on the mounting position.
- ◆ Only professional personnel are allowed for unit installation

2.4 Dimension Data

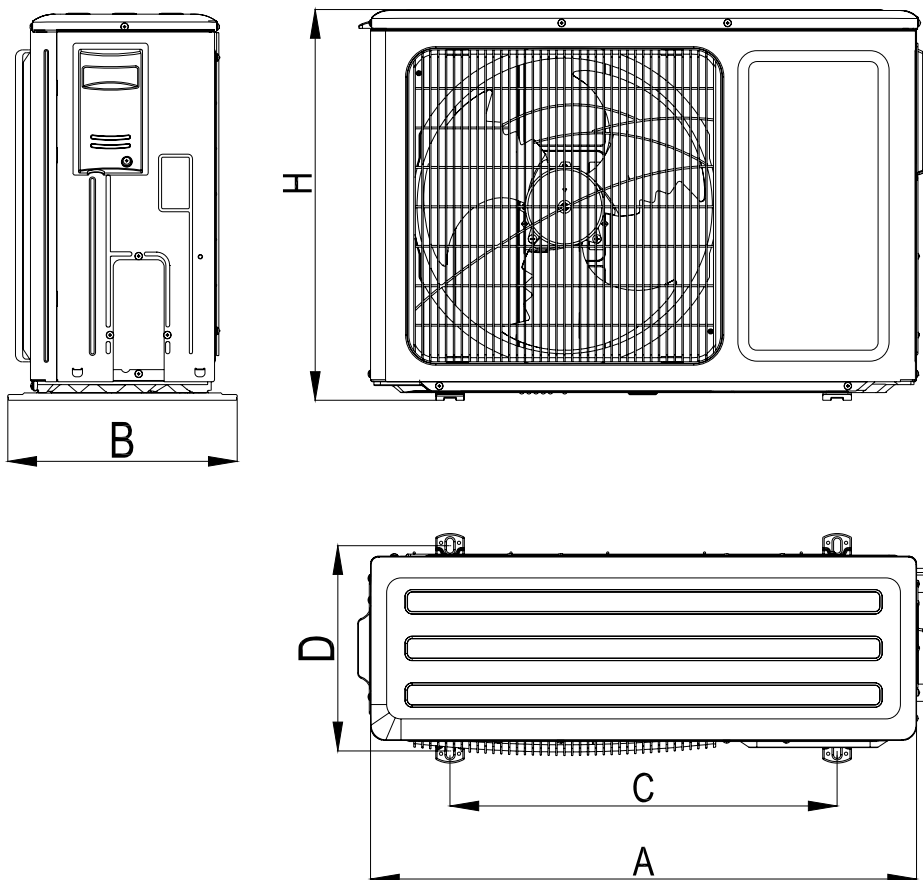

Figure 2-4-1

Unit: mm

Model	A	B	C	H	D
GUHN09NK3AO	848	320	540	540	286
GUHN12NK3AO					
GUHN18NK3AO					
GUHN24NK3AO	1018	412	700	572	300
GUHN36NK3AO	1018	412	840	572	378
GUHN36NM3AO					
GUHN42NM3AO	950	412	1250	572	378
GUHN48NM3AO					
GUHN60NM3AO					

2.5 Installation Clearance Data

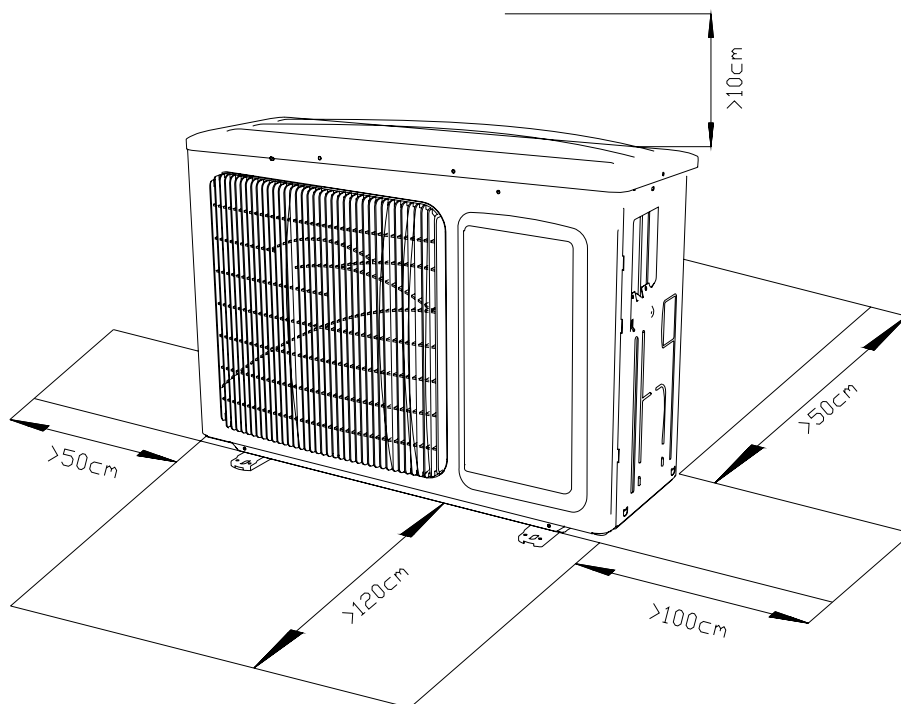

Figure 2-5-1

3 REFRIGERATION PIPING WORK

3.1 Refrigeration Piping Work Procedures

1) Connecting pipelines

- ◆ Connection pipes must be in accordance with the following requirements: the basic principle --- keeping dry, clean and no leakage inside.

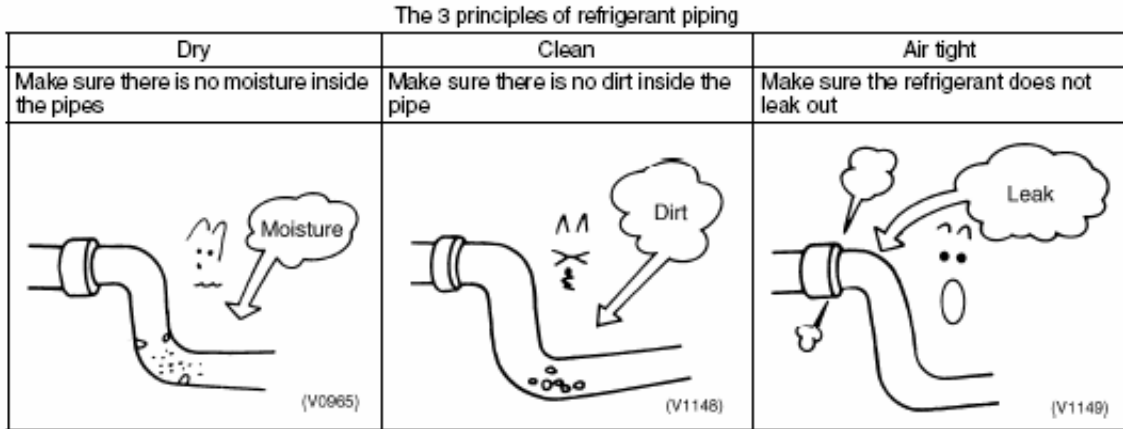

Figure 3-1-1

- ◆ Align copper pipe flare with the center of screwed connector and tighten fully the nut of the flare by hand.
- ◆ Tighten the flare nut with a torque spanner until the torque spanner makes a click, as shown in Figure 3-1-1. Moment needed for tightening a nut is shown in Tab. 3-1-1.

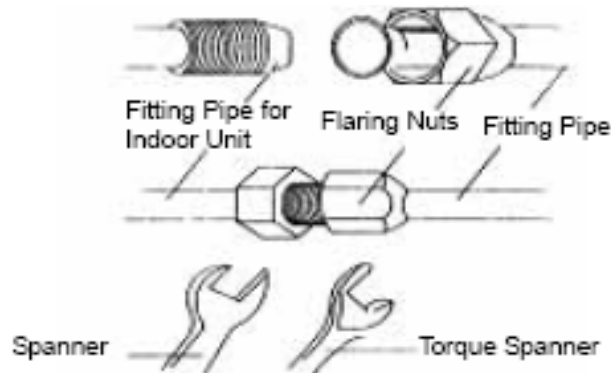

Figure 3-1-2

Form 3-1-1 the tightening torque needed for tightening nut

Pipe diameter	Tightening torque
1/4 "	15-30 (N·m)
3/8 "	35-40 (N·m)
5/8 "	60-65 (N·m)
1/2 "	45-50 (N·m)
3/4 "	70-75 N·m)

- ◆ Curvature of piping shall not be too small, or otherwise piping may be broken. So installation personnel should use a pipe bender to bend pipes.
- ◆ Upward or longitudinal welding joint method is usually applied to the welding of pipelines. The welding method that mouth of pipe is downward (face-down welding) should be avoided as far as possible, because such method is prone to welding defects and even would cause leakage, as shown in Figure 3-1-3.

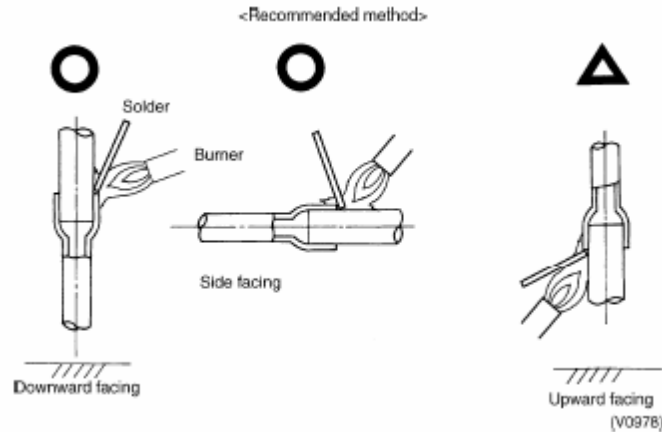

Figure 3-1-3

- ◆ Uninsulated connecting pipes and connectors should be packed with sponge and tied with plastic adhesive tapes.
- 2) Vacuum-pumping and leak detection
- ◆ Dismantle the bonnet of refrigerant valve and air valve.
 - ◆ Align with the center of piping and adequately tighten nuts of connecting pipes by hand
 - ◆ Tighten the nuts with a spanner.
 - ◆ Remove the one way valve cap of air valve.
 - ◆ Unscrew the spool of refrigerant valve for 1/4 turn with a socket head wrench, and at the same time push up the spool of air valve with a screwdriver to let air give off.
 - ◆ Air exhaust continues for 15 seconds until coolant gas appears, immediately shut off one way valve and tighten the valve cap.
 - ◆ Totally open the spool of refrigerant valve and air valve (as shown in Figure 3-1-4)

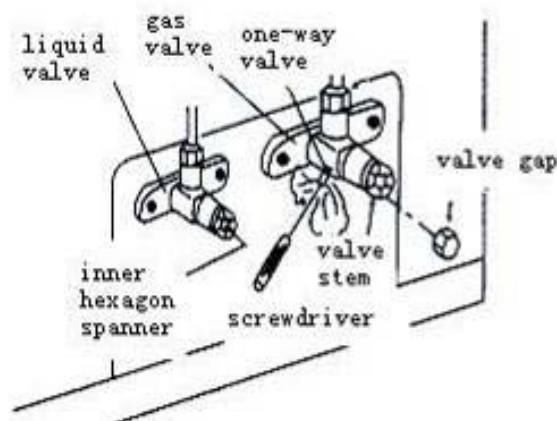

Figure 3-1-4

- ◆ Tighten the valve caps and use soapy water or a leak detector to check any leakage on indoor unit, outdoor unit and connection parts of pipes.

Caution:

If conditions are allowed, a vacuum pump shall be used for drawing off air inside the system at a valve. Method for creation of vacuum by using a vacuum pump is as follows:

- ◆ Take out the nut cover of the inlet for refrigerant.
- ◆ Connect the tube of the vacuum watch with the vacuum pump, having the low-pressure end linking to the inlet for refrigerant. (As shown in Figure 3-1-5)

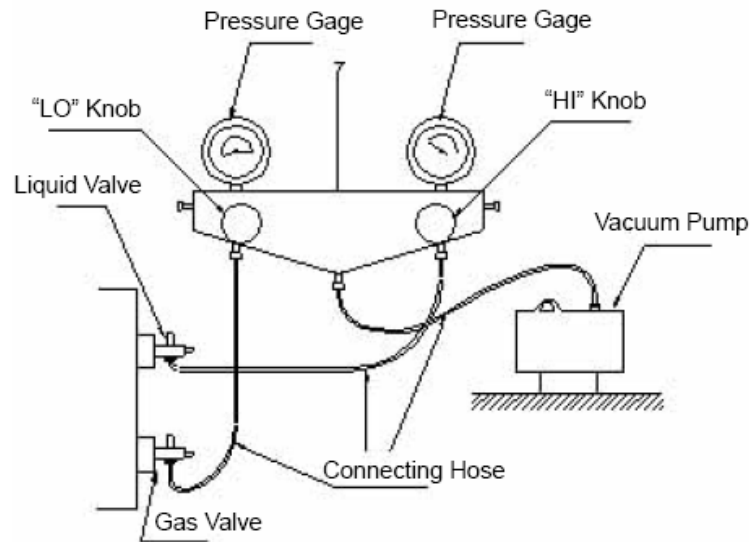

Figure 3-1-5

- ◆ Starting the vacuum pump, when the indicator turns to -1 bar, closing the low pressure handle and stopping vacuumize. Keep for 15 minutes, ensuring the pressure of the vacuum watch remains.
- ◆ Take out the valve cover of the gas valve together with the liquid valve.
- ◆ Loosing the cord of liquid valve until the pressure rise to 0 bar.
- ◆ Dismantle the tube from the cover of the inlet for refrigerant then, tighten the cover.
- ◆ Loose the valve cord of the gas valve as well as the liquid valve entirely.
- ◆ Tighten the valve cover of the gas valve and liquid valve so as to check whether leakage occurred.

3) Installation of Protective Layer of Connecting Pipe

- ◆ To avoid generation of condensate on the connecting pipe and avoid leakage, the big pipe and the small pipe of the connecting pipe must be covered by thermal insulation materials, be bundled by adhesive tape, and be isolated from air.
- ◆ The joint connecting to the indoor unit must be wrapped by thermal insulation material. There shall be no gap between the connecting pipe joint and the wall of the indoor unit. Refer

to Figure 3-1-6.

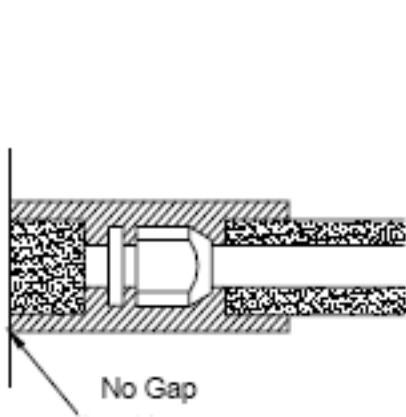

Figure 3-1-6

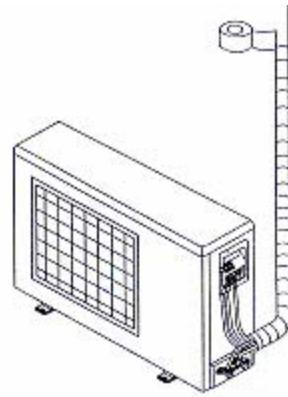

Figure 3-1-7

- ◆ Use adhesive tape to bundle the connecting pipe and the cables together. To prevent condensate from overflowing out from the drainage pipe, separate the drainage pipe from the connecting pipe and the cables.
- ◆ Use thermal insulation tape to wrap the pipes from the bottom of the outdoor unit until the upper end of the pipe where the pipe enters the wall. When wrapping thermal insulation tape, the later circle of tape must cover half of the front circle of tape (Figure 3-1-7).
- ◆ Wrapped pipe must be fixed to wall using pipe clamps.

Caution:

- ◆ After the pipes are wrapped by protective materials, never bend the pipes to form very small angle, and otherwise the pipes may crack or break.
- ◆ Do not wrap the protective tape too tight, otherwise the efficiency of thermal insulation may be decreased. Ensure that the condensate drainage flexible tube is separate from the bundled pipes.
- ◆ After the protective work is completed and the pipes are wrapped, use seal material to block the hole in the wall, so as to prevent rain and wind from entering the room.

3.2 Caution in Connecting Pipes

Arrangement of connecting pipes shall be performed according to sit conditions with reference to the following principles.

- ◆ Try to shorten the length of connecting pipes, within 5m for the better.
- ◆ Try to reduce height difference between indoor unit and outdoor unit.
- ◆ Try to reduce number of joint bends of connecting pipes.
- ◆ If the length of connecting pipes is more than 20m, adequacy of lubricant of the system must be checked; and if necessary, add more lubricant properly.
- ◆ Filling amount of refrigerant in the system is matched to a 7m connecting pipe. If the

connecting pipe is needed to lengthen, appropriate amount of refrigerant should be added. How much refrigerant should be added for every meter extension refers to the following table. Allowable maximum pipe length is 30m.

- ◆ If height difference between indoor unit and outdoor unit exceeds 10m in installation of air conditioner, an oil return bend must be mounted at an interval of 6m.
- ◆ If heights of indoor unit and outdoor unit are different, pipes should be laid out with reference to Figure 3-2-1.

———— Refrigerant pipe (thin)

- - - - - Air pipe (large)

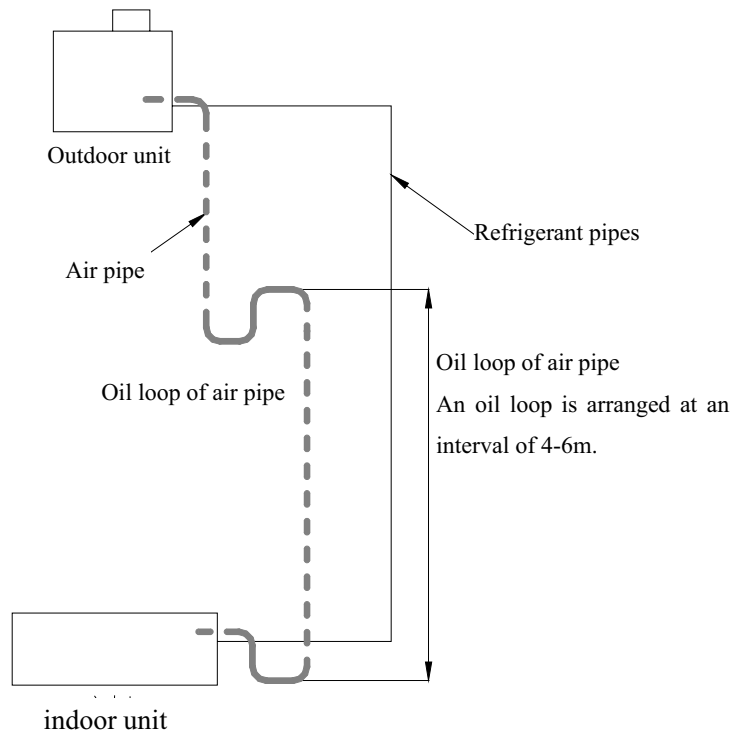

Figure 3-2-1

3.3 Specification of Connection Pipe

Model	External Diameter		Maximum Length of Connection Pipe	Maximum Difference in Height between Outdoor and Indoor Unit	Additional Charge of Refrigerant
	Gas Pipe	Liquid Pipe			
			(m)	(m)	(g/m)
GUHN09NK3AO	φ3/8 "	φ1/4 "	20	15	15
GUHN12NK3AO	φ1/2 "				
GUHN18NK3AO			30	15	60
GUHN24NK3AO	φ5/8 "	φ3/8 "			
GUHN36NK3AO	φ3/4 "	φ1/2 "	50	30	120

GUHN36NM3AO					
GUHN42NM3AO					
GUHN48NM3AO					
GUHN60NM3AO	φ7/8 "				

4 ELECTRIC WIRING WORK

4.1 Wiring Principle

4.1.1 General

- ◆ Perform wiring of the power supply in conformance with the regulations of the local electric company.
- ◆ For the control wires connecting indoor units, and between indoor and outdoor units, use of double-core shield wires is recommended to prevent noise trouble.
- ◆ Be sure to set the earth leakage breaker and the switches to the power supply section of the indoor unit.
- ◆ Supply power to each outdoor unit and provide an earth leakage breaker or hand switch for each outdoor unit.
- ◆ Store wiring system for control and refrigerant piping system in the same line.
- ◆ Arrange the cables so that the electric wires do not come to contact with high-temperature part of the refrigerant pipe; otherwise coating melts and an accident may be caused.
- ◆ Do not turn on power of the indoor unit until vacuuming of the refrigerant pipe will finish.
- ◆ Installation should be conducted by National Wiring Regulation.
- ◆ The rated voltage and exclusive power supply must be adopted for the air conditioners.
- ◆ The power cable should be reliable and fixed, in order to avoid the wiring terminal be suffered from force. And do not drag the power cable forcibly.
- ◆ The wire diameter of power cable should be large enough, if power cable and connection wire be damaged, it should be replaced by the exclusive cable.
- ◆ All electric installation must be done by professional personnel according to local law, regulation and this manual.
- ◆ It should be reliably earthed, and it should be connected to the special earth device, the installation work should be operated by the professional.
- ◆ The creepage protect switch and air switch must be installed.
- ◆ Air switch should have the thermal dropout and magnetic dropout function, in order to avoid the short circuit and overload.
- ◆ The on spot connection should refer to the circuit diagram, which is stuck on the unit body.
- ◆ The unit should be reliably earth, if it is improperly earthed that may cause electric shock or fire.

- ◆ Air conditioner is the “I” class electric appliance, thus please do conduct reliable grounding measure.
- ◆ The yellow-green two-color wiring of air conditioner is grounding wire and cannot be used for other purposes. It cannot be cut off and be fixed by screw, otherwise it would cause electric shock.
- ◆ The user must offer the reliable grounding terminal. Please don't connect the grounding wire to the following places:
 - ① Water pipe;
 - ② Gas pipe;
 - ③ Blowing pipe;
 - ④ Other places that professional personnel consider them unreliable.

4.1.2 Connection of electric wires with the terminal

1) Caution

Before installing the electrical equipment, please pay attention to the following matters which have been specially pointed out by our designers:

- ① Check to see if the power supply used conforms to the rated power supply specified on the nameplate.
- ② The capacity of the power supply must be large enough. The section area of fitting line in the room shall be larger than 2.5mm².
- ③ The lines must be installed by professional personnel.
- ④ An electricity leakage protection switch and an air switch with gap between electrode heads larger than 3 mm shall be installed in the fixed line.

2) Connection of single wire

- ① Use wire stripper to strip the insulation layer (25mm long) from the end of the single wire.
- ② Remove the screw at the terminal board of the air-conditioning unit.
- ③ User pliers to bend the end of the single wire so that a loop matching the screw size is formed.
- ④ Put the screw through the loop of the single wire and fix the loop at the terminal board.

3) Connection of multiple twisted wires

- ① Use wire stripper to strip the insulation layer (10mm long) from the end of the multiple twisted wires.
- ② Remove the screw at the terminal board of the air-conditioning unit.
- ③ Use crimping pliers to connect a terminal (matching the size of the screw) at the end of the multiple twisted wires.
- ④ Put the screw through the terminal of the multiple twisted wires and fix the terminal at the terminal board.

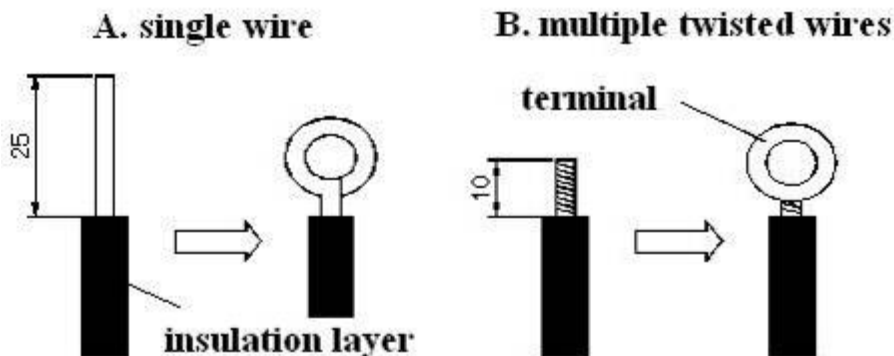

Warning:

- ◆ If the power supply flexible line or the signal line of the equipment is damaged, only use special flexible line to replace it.
- ◆ Before connecting lines, read the voltages of the relevant parts on the nameplate. Then carry out line connection according to the schematic diagram.
- ◆ The air-conditioning unit shall have special power supply line which shall be equipped with electricity leakage switch and air switch, so as to deal with overload conditions.
- ◆ The air-conditioning unit must have grounding to avoid hazard owing to insulation failure.
- ◆ All fitting lines must use crimp terminals or single wire. If multiple twisted wires are connected to terminal board, arc may arise.
- ◆ All line connections must conform to the schematic diagram of lines. Wrong connection may cause abnormal operation or damage of the air-conditioning unit.
- ◆ Do not let any cable contact the refrigerant pipe, the compressor and moving parts such as fan.
- ◆ Do not change the internal line connections inside the air-conditioning unit. The manufacturer shall not be liable for any loss or abnormal operation arising from wrong line connections.

4.1.3 Power Cable Connection**1) Air-conditioning unit with single-phase power supply**

- ① Remove the front-side panel of the outdoor unit.
- ② Pass the cable through rubber ring.
- ③ Connect the power supply cable to the “L, N” terminals and the grounding screw.
- ④ Use cable fastener to bundle and fix the cable.

2) Air-conditioning unit with 3-phase power supply

- ① Remove the front-side panel of the outdoor unit.
- ② Attach rubber ring to the cable-cross hole of the outdoor unit.
- ③ Pass the cable through rubber ring.
- ④ Connect the power cable to the terminal and earthing screws marked “L1, L2, L3 & N”.
- ⑤ Use cable fastener to bundle and fix the cable.

Caution:

- ◆ For air-conditioner with auxiliary heater, it is required to connect the power cable to the “L1, L2, L3” terminals and the grounding screw.

4.1.4 Connection of Signal Line of Wire Controller**Caution:**

Take great care when carrying out the following connections, so as to avoid malfunction of the air-conditioning unit because of electromagnetic interference.

- ◆ The signal line of the wire controller must be separated from the power line and the

connecting line between the indoor unit and the outdoor unit.

- ◆ ◆ In case the unit is installed in a place vulnerable by electromagnetic interference, it is better to use shielded cable or double-twisted cable as the signal line of the wire controller.
- ◆ Open the cover of the electric box of the indoor unit.
- ◆ Pull the signal cable of the wire controller through the rubber ring.
- ◆ Plug the signal line of the wire controller onto the 4-bit pin socket at the circuit board of the indoor unit.
- ◆ Use cable fastener to bundle and fix the signal cable of the wire controller.

4.1.5 Connection of wires

- ① Remove the board on the right side of outdoor unit and put through the wire running hole on the outdoor unit and put on a rubber ring.
- ② Remove wire holders and connect the power cord to the terminal and fix it.
- ③ Secure the power connecting cord and signal control cable with wire holders and then connect corresponding adapters.
- ④ Check if wires are fixed properly.
- ⑤ Fit on the front side board.

4.2 Electric Wiring Design

4.2.1 GUHN09NK3AO+GFH09K3BI, GUHN12NK3AO+GFH12K3BI,
 GUHN18NK3AO+GFH18K3BI, GUHN24NK3AO+GFH24K3BI,
 GUHN36NK3AO+GFH36K3BI

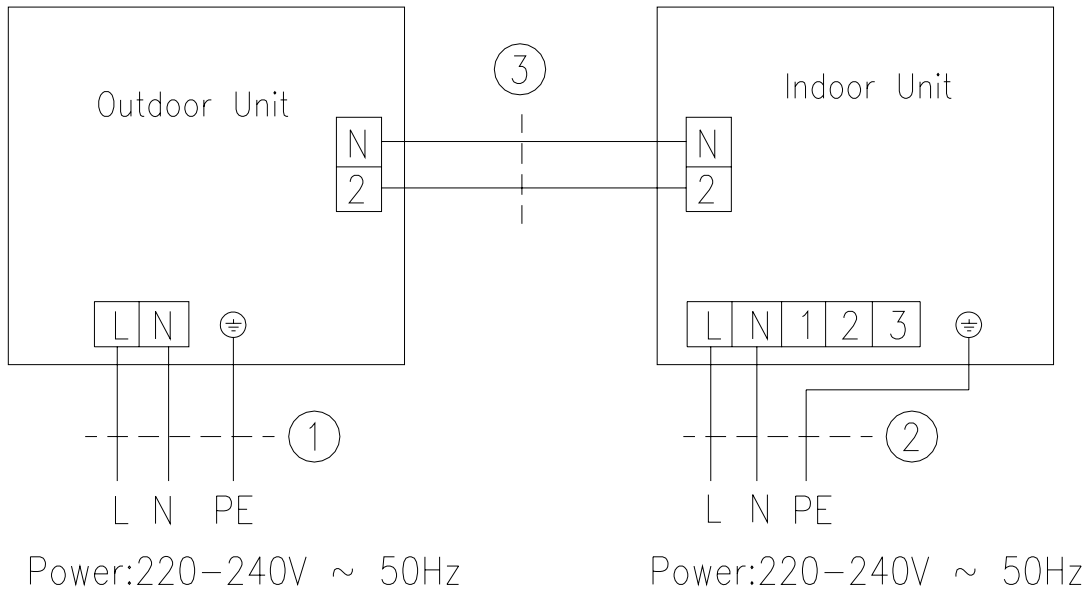

GUHN36NM3AO+GFH36K3BI, GUHN42NM3AO+GFH42K3BI,
 GUHN48NM3AO+GFH48K3BI, GUHN60NM3AO+GFH60K3BI

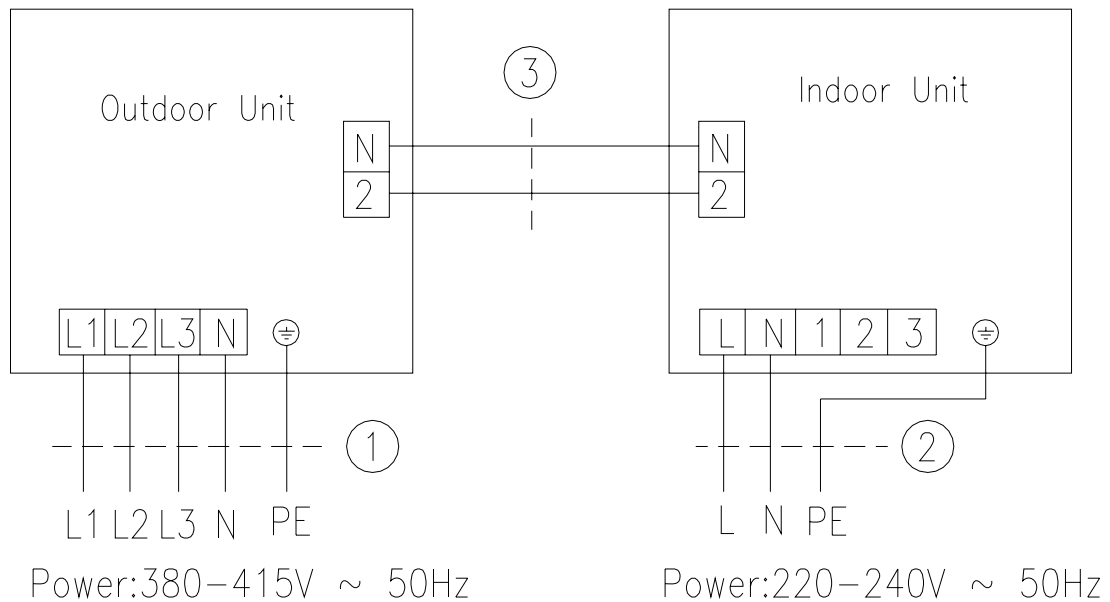

4.2.2 GUHN09NK3AO+GTH09K3BI、GUHN12NK3AO+GTH12K3BI、
 GUHN18NK3AO+GTH18K3BI、GUHN24NK3AO+GTH24K3BI、
 GUHN36NK3AO+GTH36K3BI

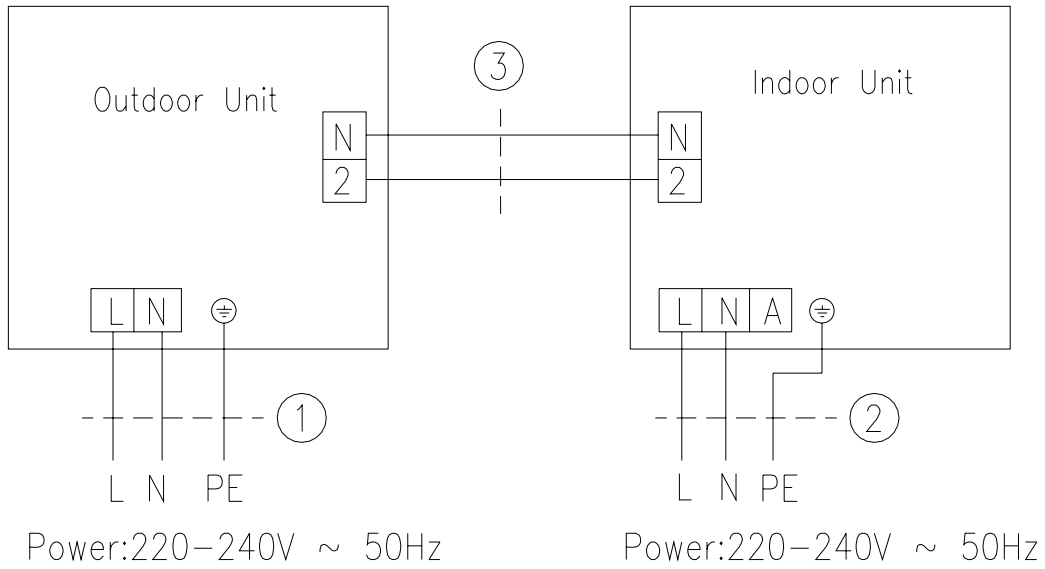

GUHN36NM3AO+GTH36K3BI、GUHN42NM3AO+GTH42K3BI、
 GUHN48NM3AO+GTH48K3BI、GUHN60NM3AO+GTH60K3BI

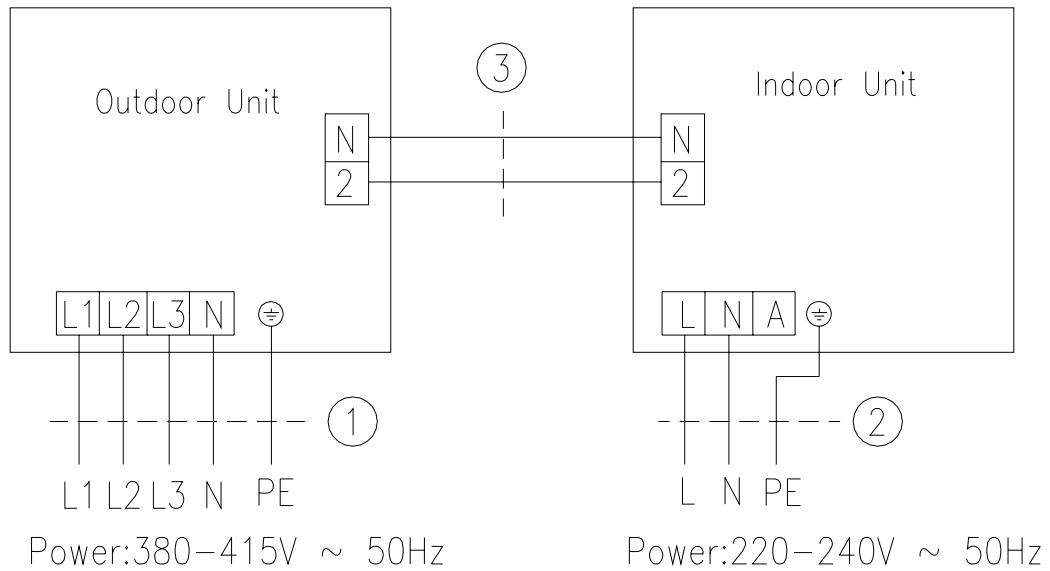

4.2.3 GUHN09NK3AO+GKH09K3BI、GUHN12NK3AO+GKH12K3BI、
 GUHN18NK3AO+GKH18K3BI、GUHN24NK3AO+GKH24K3BI、
 GUHN36NK3AO+GKH36K3BI

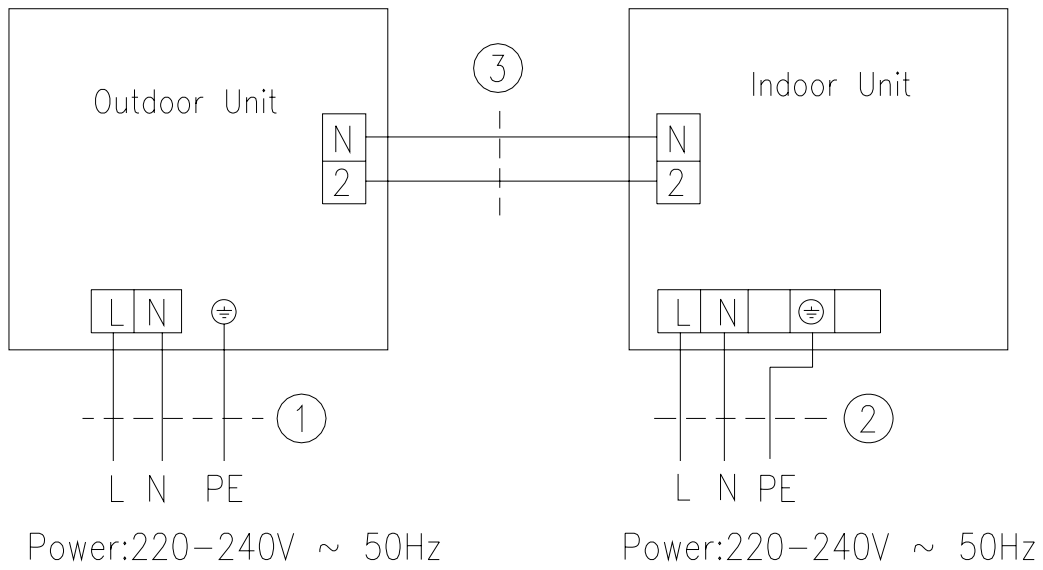

GUHN36NM3AO+GKH36K3BI、GUHN42NM3AO+GKH42K3BI、
 GUHN48NM3AO+GKH48K3BI、GUHN60NM3AO+GKH60K3BI

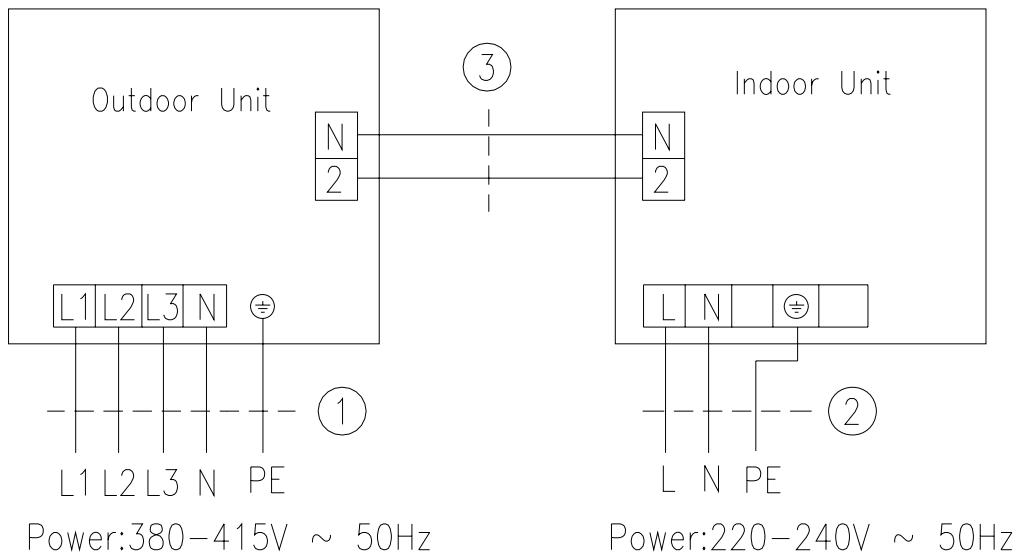

4.3 Specification of Power Supply Wire and Air Switch

4.3.1 Outdoor Unit

Model	Power Supply (V, Ph, Hz)	Capability of Air Swith	Minimum Sectional Area of Earth Wire	Minimum Sectional Area of Power Supply Wire
		(A)	(mm ²)	(mm ²)
GUHN09NK3AO	220-240, 1, 50	10	1.5	1.5
GUHN12NK3AO	220-240, 1, 50	13	1.5	1.5
GUHN18NK3AO	220-240, 1, 50	20	2.5	2.5
GUHN24NK3AO	220-240, 1, 50	25	4.0	4.0
GUHN36NK3AO	220-240, 1, 50	40	6.0	6.0
GUHN36NM3AO	380-415, 3, 50	16	2.5	2.5
GUHN42NM3AO	380-415, 3, 50	20	2.5	2.5
GUHN48NM3AO	380-415, 3, 50	20	2.5	2.5
GUHN60NM3AO	380-415, 3, 50	20	2.5	2.5

4.3.2 Indoor Unit

● Duct Type

Model	Power Supply (V, Ph, Hz)	Capability of Air Swith	Minimum Sectional Area of Earth Wire	Minimum Sectional Area of Power Supply Wire
		(A)	(mm ²)	(mm ²)
GFH09K3BI	220-240, 1, 50	6	1.0	1.0
GFH12K3BI	220-240, 1, 50	6	1.0	1.0
GFH18K3BI	220-240, 1, 50	6	1.0	1.0
GFH24K3BI	220-240, 1, 50	6	1.0	1.0
GFH36K3BI	220-240, 1, 50	10	1.5	1.5
GFH42K3BI	220-240, 1, 50	10	1.5	1.5
GFH48K3BI	220-240, 1, 50	10	1.5	1.5
GFH60K3BI	220-240, 1, 50	10	1.5	1.5

- Ceiling Type

Model	Power Supply (V, Ph, Hz)	Capability of Air Swith	Minimum Sectional Area of Earth Wire	Minimum Sectional Area of Power Supply Wire
		(A)	(mm ²)	(mm ²)
GTH09K3BI	220-240, 1, 50	6	1.0	1.0
GTH12K3BI	220-240, 1, 50	6	1.0	1.0
GTH18K3BI	220-240, 1, 50	6	1.0	1.0
GTH24K3BI	220-240, 1, 50	6	1.0	1.0
GTH36K3BI	220-240, 1, 50	6	1.0	1.0
GTH42K3BI	220-240, 1, 50	6	1.0	1.0
GTH48K3BI	220-240, 1, 50	6	1.0	1.0

- Cassette Type

Model	Power Supply (V, Ph, Hz)	Capability of Air Swith	Minimum Sectional Area of Earth Wire	Minimum Sectional Area of Power Supply Wire
		(A)	(mm ²)	(mm ²)
GKH12K3BI	220-240, 1, 50	6	1.0	1.0
GKH18K3BI	220-240, 1, 50	6	1.0	1.0
GKH24K3BI	220-240, 1, 50	6	1.0	1.0
GKH36K3BI	220-240, 1, 50	6	1.0	1.0
GKH42K3BI	220-240, 1, 50	6	1.0	1.0
GKH48K3BI	220-240, 1, 50	6	1.0	1.0

MAINTENANCE

MAINTENANCE**1 TROUBLE TABLE**

Trouble Code	Trouble Name	Origin of Trouble Signal	Control Description
E0	Pump Failure	Pump	If water full protection continues for 2 hours and fails to restore, it is believed that the water pump is at fault and all loads are shut off and fail to restore automatically.
E1	Compressor High Pressure Protection	High voltage switch	When high voltage protection is detected for continuous 3 seconds, all loads are shut off (except for the four way valve), all buttons and remote control signals except for power-on or power-off are shielded and fail to restore automatically, the machine should be powered off and on, or failure should be removed after power supply is restored.
E2	Indoor Frost-Proof Protection	Evaporator of indoor unit Thermal bulb	When the unit has been running for refrigeration or dehumidification for a period of time and evaporator thermal bulb is detected to be lower than -2°C, the unit will report a fault and stops the compressor and the outdoor unit. The unit will begin to operate after temperature is $\geq 10^{\circ}\text{C}$ and the compressor keeps outage for 3 minutes.
E3	Compressor Low Pressure Protection	Low voltage switch	When the unit is started or at standby (detection will begin 3 minutes after the compressor is started up) and detected breakdown of the low voltage switch for continuous 30 seconds, a fault is reported. The unit can be restored automatically after the first 2 reported faults within 30 minutes. The third reported fault and so on can not be restored automatically.
E4	Compressor Exhaust High Temperature Protection	Discharge thermal bulb	After the compressor is started, if discharge temperature is detected to be more than or equal to 130 degree for continuous 30 seconds, E4 will be displayed, all loads (except for the four way valve) will be shut off, the compressor will stop for 3 minutes and the complete system will restore after discharge temperature is lower than 90 degree. If such fault is reported for successive three times, the protection can not be restored itself.
E5	Compressor Overheat	Compressor	After the compressor is started, if the overload switch of the compressor is detected to shut off, the fault is reported. All loads (except for the four way valve) are shut off, the fault is displayed, and the compressor will stop for 3 minutes. If the fault is removed, the compressor can be restarted to run. If successive three compressor overload protection faults are detected within

Trouble Code	Trouble Name	Origin of Trouble Signal	Control Description
			30 minutes, the unit can not be restored itself and the buzzer will give out an alarm. Push the ON/OFF button to shut off the unit. And then push ON/OFF button again, if high voltage protection disappears, operation will restore, or otherwise, the fault is displayed.
E6	Communications Failure	Communication	When outdoor unit is energized and fails to receive data of indoor unit within 30 seconds, an indoor unit communication fault is reported. The compressor and the outdoor unit will be shut off, and the four way valve will be stopped 2 minutes after the compressor outage in heating state. If indoor unit fails to receive information of outdoor unit, a communication fault is reported. The indoor unit is shut off and an indicator is twinkling. If the display board fails to receive information of outdoor unit, a communication fault is determined and displayed and the machine does not actuate. After communication becomes normal, the system can restore to the previous running state itself.
E8	Indoor Fan Protection	Indoor unit	If fan overload protection is detected for continuous 3 seconds, relevant compressor and fan shall be shut off immediately and a fault code E8 is displayed, and at the same time, the buzzer gives out an alarm. Push the ON/OFF key, if the fault disappears, clear the fault display and push the ON/OFF key for restarting the system.
E9	Full Water Protection	Liquid level switch	Water full is detected for continuous 8 seconds after the system is powered on, the water full protection is initiated and the indicator is twinkling (or E9 is displayed). Under refrigeration and dehumidification mode, the outdoor fan and the compressor are shut off and the indoor fan stops after 1 minute delay; under heating mode, the outdoor fan and the compressor are shut off, the four way valve keeps at the previous status, and the indoor fan stops after 1 minute delay; under air supply mode, the load of indoor unit remains.
F0	Failure of Indoor Room Sensor at Air Intake	Indoor environment Thermal bulb	Open-circuit or short-circuit of the indoor environment thermal bulb is detected for continuous 5 seconds, indoor environment temperature will be set compulsively at 24 degree, the system does not take any measure, and only the indicator is twinkling or fault code F0 is displayed. After the fault is removed, the system can restore operation by itself. Under air supply mode, only the

Trouble Code	Trouble Name	Origin of Trouble Signal	Control Description
			fault is displayed and the indoor fan is running normally. The fault display disappears when the fault is removed.
F1	Failure of Evaporator Temp. Sensor	Indoor evaporator thermal bulb	Open-circuit or short-circuit of evaporator thermal bulb is detected for continuous 5 seconds, under refrigeration and dehumidification mode, the system will be shut off; and under heating mode, all loads except for the four way valve are shut off. The indicator is twinkling or fault code F1 is displayed. The system can restore by itself and display fault elimination after the fault is removed. Under air supply mode, only the fault is displayed and the indoor unit is running normally. The fault display disappears when the fault is removed.
F2	Failure of Condenser Temp. Sensor	Outdoor condenser thermal bulb	Open-circuit or short-circuit of condenser thermal bulb is detected for continuous 5 seconds, under refrigeration and dehumidification mode, the system will be shut off; and under heating mode, all loads except for the four way valve are shut off. The indicator is twinkling or fault code F2 is displayed. The system can restore by itself and display fault elimination after the fault is removed. Under air supply mode, only the fault is displayed and the indoor unit is running normally. The fault display disappears when the fault is removed. For other types of refrigeration machines except for air duct machine, condenser thermal bulb is not detected.
F3	Failure of Outdoor Ambient Sensor	Outdoor environment thermal bulb	Open-circuit or short-circuit of outdoor environment thermal bulb is detected for continuous 5 seconds, under refrigeration and dehumidification mode, the system will be shut off; and under heating mode, all loads except for the four way valve are shut off. The indicator is twinkling or fault code F3 is displayed. The system can restore by itself and display fault elimination after the fault is removed. Under air supply mode, only the fault is displayed and the indoor unit is running normally. The fault display disappears when the fault is removed.
F4	Failure of Exhaust Temp. Sensor	Discharge thermal bulb	After the compressor is started, open-circuit of discharge thermal bulb is detected for continuous 5 seconds. Under refrigeration and dehumidification mode, all loads will be shut off. Under heating mode, all loads except for the four way valve are shut off. The indicator is twinkling or fault code F4 is displayed. And the buzzer gives out an alarm. After the fault is removed, the system will restore by itself and clear the fault code.

Trouble Code	Trouble Name	Origin of Trouble Signal	Control Description
			If discharge thermal bulb is short circuited, under refrigeration and dehumidification mode, all loads will be shut off. Under heating mode, all loads except for the four way valve are shut off. The indicator is twinkling or fault code F4 is displayed. And the buzzer gives out an alarm. After the fault is removed, the system will restore by itself and clear the fault code.
F5	Failure of Indoor Room Sensor at Wire Controller	Line controller	Open-circuit or short-circuit of line controller thermal bulb is detected for continuous 5 seconds, indoor environment temperature will be set compulsively at 24 degree, the system does not take any measure, and only the indicator is twinkling or fault code F0 is displayed. After the fault is removed, the system can restore operation by itself. Under air supply mode, only the fault is displayed and the indoor fan is running normally. The fault display disappears when the fault is removed.

2 FLOW CHART OF TROUBLESHOOTING

Service personnel shall collect the malfunction information as much as possible and research them thoroughly, list these electrical parts which may cause malfunction, service personnel shall be able to determine the specific reason and solve the faulted parts.

- Observe the status of the complete device and do not observe the partial
- It is advised to start from the simple operation during analyzing ,judging and confirming malfunction reason, then conduct the complicated operations such removal of device, part replacement and refrigerant filling.
- Find the malfunction reason carefully as unit may occur several malfunction at the same time and one malfunction may develop into several malfunction, so entire system analysis shall be established to make the judged result exact and credible .

◆ Malfunction display: E1 Compressor High Pressure Protection

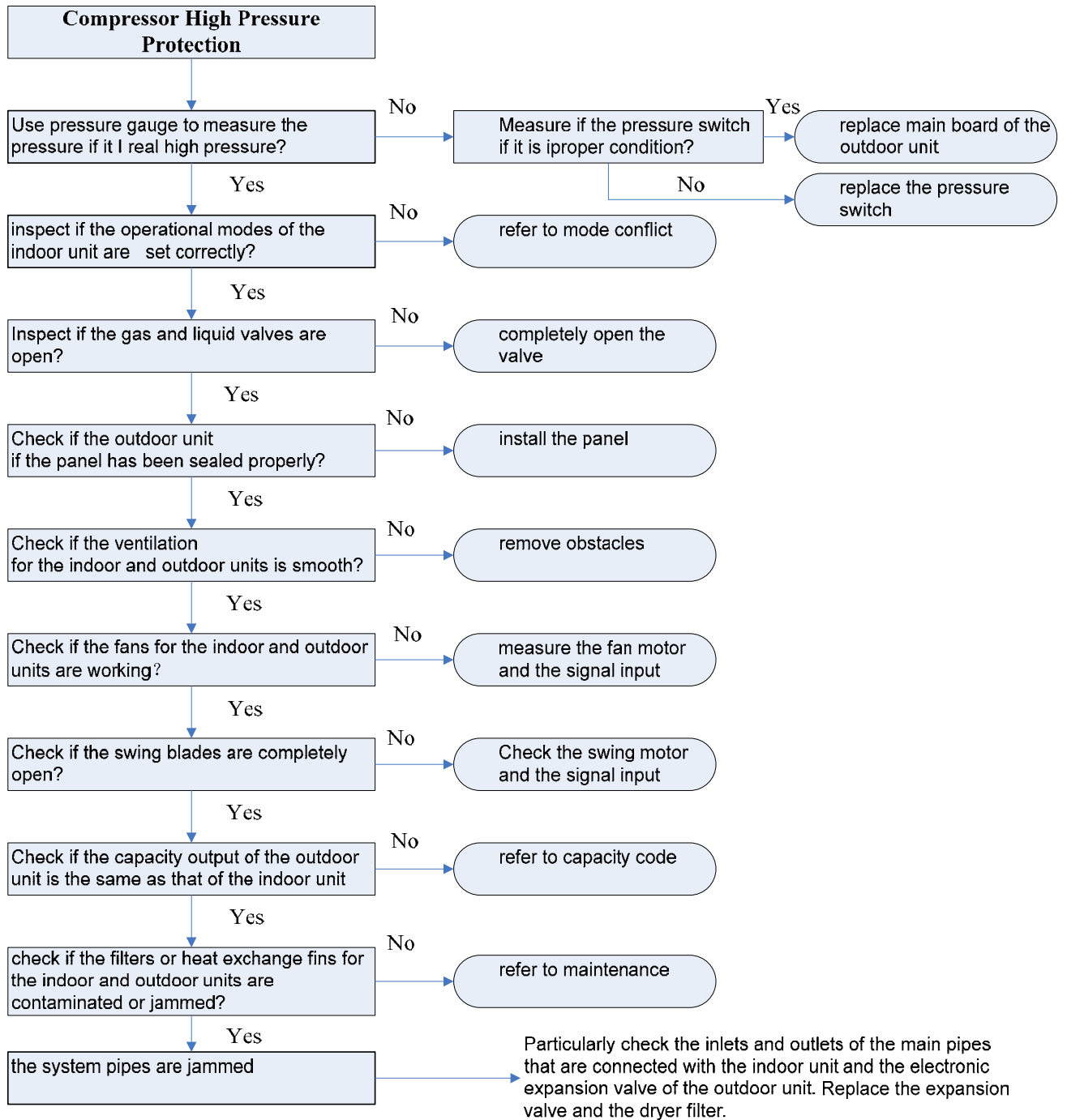

◆ Malfunction display: E3 Compressor Low Pressure Protection

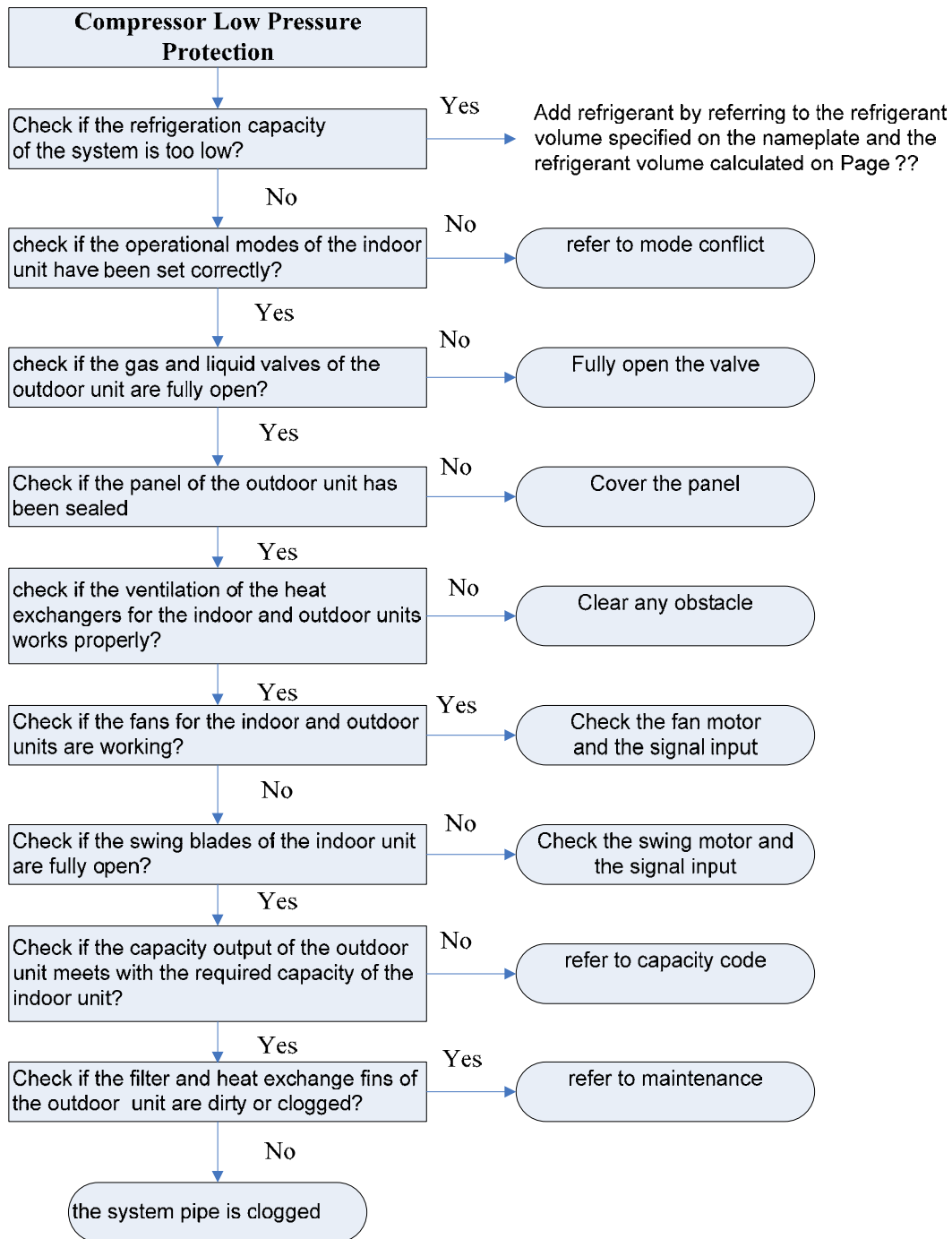

◆ Malfunction display: E4 Compressor Exhaust High Temperature Protection

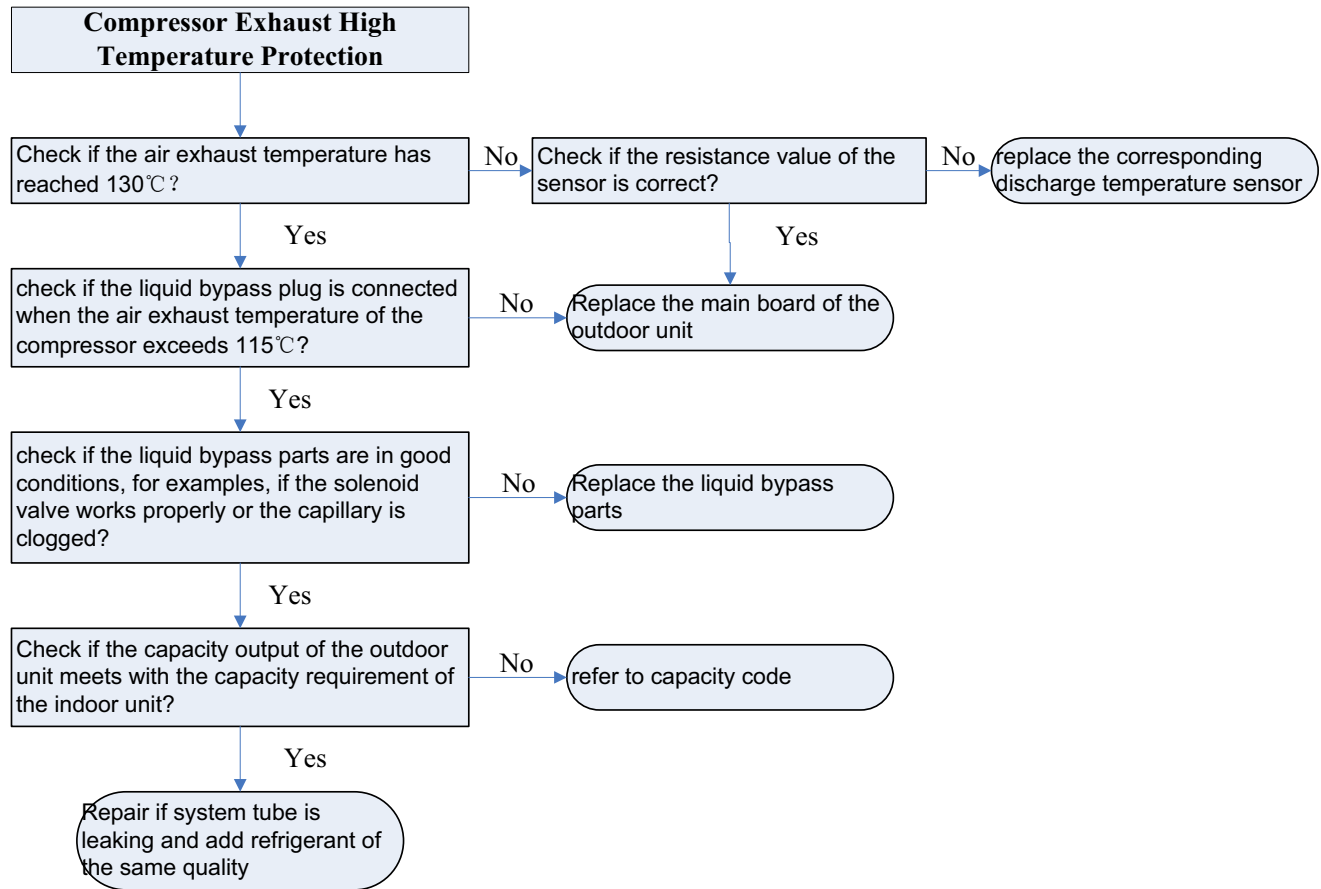

◆ Malfunction display: E5 Compressor Overheat

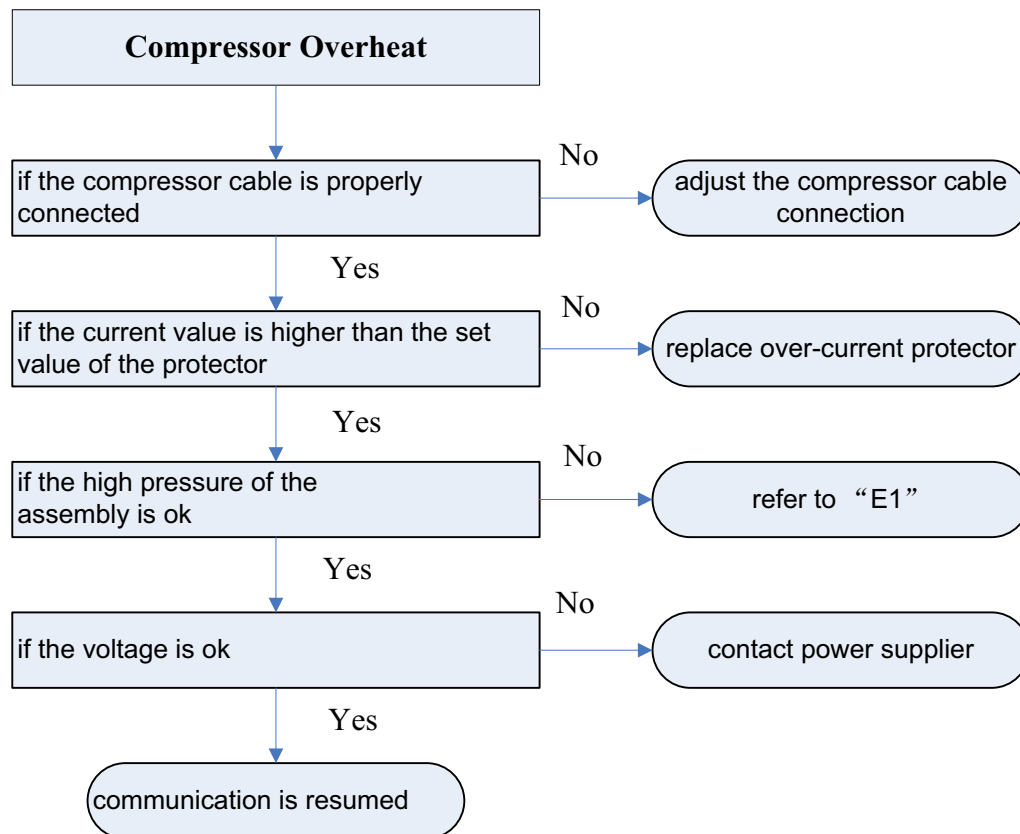

◆ Malfunction display: E6 Communications Failure

