

**TECHNICAL SALES GUIDE-50HZ
CAPACITY RANGE: 20-40KW
SUPER HIGH AMBIENT OPERATION TO 43°C**



R410A

CONTENTS

1.MODELS LIST	3
2.NOMENCLATURE	4
3.FUNCTION	5
4.FEATURES	9
5.FAN CHARACTERISTICS	20
6.CLEARANCE DATA	21
7.DIMENSIONAL DATA	23
8.ACCESSORIES	25

1 MODELS LIST

Units Series	Model	Capacity (kW/Ton)		Ref	Appearance	
		Cooling	Heating		Outdoor	Indoor
Duct Type	FGR20/BNa-M	20/5.6	22/6.2	R410A		
	FG20/ BNa-M	20/5.6	/			
	FGR25/ BNa-M	24.5/6.9	27.5/7.7			
	FG25/ BNa-M	24.5/6.9	/			
	FGR30/ BNa-M	30/8.4	33/9.2			
	FG30/ BNa-M	30/8.4	/			
	FGR40/ BNa-M	39.5/11.1	42/11.8			
	FG40/ BNa-M	39.5/11.1	/			

Note: 1Ton = 12000Btu/h = 3.517Kw

2 NOMENCLATURE

➔ Electra Single Air Conditioners

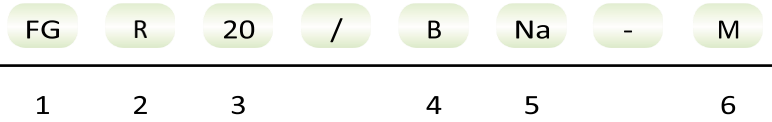

NO.	Description	Options
1	Ducted Type Air Conditioner	—
2	Product Type	Omitted =Cooling only type R= Heat pump type
3	Cooling Capacity	Nominal cooling capacity (kW)
4	Design Sequence	Omitted—the basic design A—the first improvement B—the second improvement
5	Refrigerant	Na—R410A Omitted—R22
6	Power Supply Code	K=1Ph,220~240V,50Hz M=3Ph,380~415V,50Hz

3 FUNCTION

➔ 3.1 Description

ELECTRA Series Ducted type Air-conditioning Units has combined the comfort, top grade from the central air conditioners as well as the convenient installation and facility from the mini type of the split air conditioners. ELECTRA FG Series Ducted type can offer the perfect combination of superior product quality, operating efficiency and value for money. These units are available in vertical discharge configurations, as cool only models. All capacities are rated according to the relevant ASHRAE Standards. These units are CE certified and are manufactured under strict quality control with full conformance to ISO 9001:2000 and ISO 14001 standards. ELECTRA FG Series Ducted type can offer the high static pressure indoor unit. And the static pressure is alterable by changing the strap wheel. The static pressure range is from 0Pa to 250Pa. The capacity range is from 20KW to 40KW. It could be sufficient to the different requirements from customers.

The FG Series Ducted Air-conditioning Units can be widely used in supermarkets, chain stores, hotels, restaurants, offices and meeting rooms etc. Its especially fit for the small commercial and industrial application.

➔ 3.2 Features- Outdoor Units

Features	Description
Quality Condenser Coil	The coil is constructed of hydrophilic aluminum sheet and inner groove copper pipe
Coil Protected	Coils are protected from damage by a metal grill.
Protected Compressor	High / low pressure protection, Discharge high temperature protection, Overload protection, Reverse (open) phase protection, Sensor malfunction alarm
Resisting Corrosion	Cabinet is made of pre-painted steel. The pre-treated flat galvanized steel provides a better paint to steel bond, which resists corrosion and rust creep . Special primer formulas ensure minimal fading when exposed to sunlight.
Low Operating Sound Level	Low noise fan and low noise compressor with isolator
Low Maintenance	Quality compressor and motor are used
Factory Tested	All units are factory tested prior to dispatch to verify system operation and control functioning before shipment



3.3 Features- Indoor Units

Features	Description
Flexible Installation	Condensation water exit direction can be selected flexibly
Long-distance Duct Air Supply	It adopts high static pressure design, so air is centralized handling in the indoor unit and implant long-distance duct air supply
The Capacity Range	The capacity range is 20KW to 40KW
Convenient Operation	Simple controller and intelligent remote controller make unit more convenient operation.
Good Indoor Air Quality	It can connect many supply-air outlet to the duct, so that it can make the temperature and humidity of the whole room equality, meanwhile, it can lead in fresh air, makes well indoor unit air quality. All units are provided with filters that are easily accessible from the rear of the unit.
Microcomputer Control	The controls provide for compressor delay protection, Remote control function ,temperature setting ,fan function,Sleep function,Memory function, Self-diagnosis with alarm function etc.
Quality Evaporator Coil	Evaporator coils are constructed of inner groove copper pipe and hydrophilic aluminum sheet.
Low Operating Sound	The fan motors are resilient mounted to minimize vibration and noise

3.4 The Unit Function

Control Function	Protection Function	Display Function
Memory function	High/Low pressure protection	Timing ON/OFF display
Remote control function	Overload protection	Fan speed display
Timing function	Over current protection	Function model display
Self-diagnosis with alarm function	Discharge high temperature protection	Testing display
Sleep function	Reverse (open) phase protection	Sleep mode display
Automatic function	Anti-high temperature protection	Temperature display
Cool air proof function	Sensor malfunction alarm	Malfunction code display
Centralized Control ★		
Low temperature cooling		

Control function

- Memory function: When unit restart after power off, it will run on former status, the mode and parameter are kept the same.
- Remote control function: Wireless controller and remote controller can be opted, and maximum control distance of remote controller is 10m.
- Timing function: It can timing ON/OFF separately, meanwhile, it can also can timing on circularly.
- Self-diagnosis with alarm function: Once unit has malfunction, the malfunction code will be indicated and alarm ring immediately.
- Automatic model function: The fan of indoor unit can adjust fan speed automatically based on actual demand when cooling or heating under automatic mode.
- Cool air proof function: The fan starts only when the temperature of indoor unit heat exchanger is higher than indoor temperature under heating mode.
- Blow residual heat function: Under heating mode, fan of indoor unit will work for a period after compressor stops.

Protection function

- High/low pressure protection: When suction pressure is too low or discharge pressure is too high, compressor will stop and unit display malfunction code.
- Overload protection: Compressor has its own overheat protection, once the temperature of compressor is higher than allowable level, compressor will stop and only when temperature recovery, compressor restart.
- Over current protection: Once the current of compressor is higher than normal level, compressor will stop and unit display malfunction code.
- Discharge high temperature protection: Once the discharge temperature of compressor is higher than allowable value, compressor will stop and unit display malfunction code.
- Reverse (open) phase protection: Once the phase sequence of power supply is incongruent or the phase is absent, unit can't work .
- Anti-high temperature protection: Once the heat exchanger temperature of indoor unit is too high, outdoor fan stop.
- Sensor malfunction alarm: Once the sensor short out or shutdown, unit will display malfunction code.

Display function

- Time display: Display and set real time.
- Timing turn ON/OFF display: Display and timing turn ON/OFF time.
- Cancel timing display: Display the cancel of timing.
- Fan speed display: Display the speed (high, medium, low) of fan, But the fan motor is single speed.
- Function mode display: Cooling mode, dehumidifying mode, heating mode, fan mode.
- Testing display: Display testing mode.
- Energy efficiency display: Display energy saving mode.
- Temperature display: Display room temperature and set temperature. Malfunction code display.

4 FEATURES

➔ 4.1 Product Data at Rated Condition

Due to continues improvement on the products, the specifications listed above are subject to change without notice, and the ones on the products nameplate should be referred to as final.

Models		Indoor	FG20/BNa-M(I)	FG25/BNa-M(I)	FG30/BNa-M(I)	FG40/BNa-M(I)	
		Outdoor	FG20/BNa-M(O)	FG25/BNa-M(O)	FG30/BNa-M(O)	FG40/BNa-M(O)	
Nominal Capacity At Rated ESP	Cooling	kW	20	25	30	40	
		Btu/h	68000	83597	102000	134780	
	Heating	kW	/	/	/	/	
		Btu/h	/	/	/	/	
Power input	Cooling	kW	8.4	9.8	12.5	15.8	
	Heating	kW	/	/	/	/	
Running Current	Cooling	A	15.3	22.2	23.4	30	
	Heating	A	/	/	/	/	
Power Supply		V/Ph/Hz	380-415V 3N~50Hz				
Refrigerant Type		R410A					
Refrigerant Charge		kg	5.3	6.7	9.5	12	
Indoor Unit	Power Supply		V/Ph/Hz	380-415V 3N~50Hz			
	Fan	Type	Centrifugal				
		Air flow	CFM	2380	2825	3230	4120
			m3/h	4000	4800	5500	7000
		Rated ESP	in.wg	0.8	0.44	0.48	0.6
	Pa		200	110	120	150	
	Sound Pressure L.	dB(A)	56	54	57	58	
	Outline Dimension (WxDxH)		mm	1463 × 799 × 389	1500 × 1000 × 500	1500 × 1000 × 500	1700 × 1100 × 650
Net Weight		kg	86	150	156	205	
O. Unit	Power Supply		V/Ph/Hz	380-415V 3N~50Hz			
	Sound Pressure Level		dB(A)	65	66	67	69
	Compressor	Compressor Type	Scroll				
		Nominal Current	A	14.3	16.4	20.7	27.6
	Fan	Fan Speed	rpm	850	850	660	730
	Outline Dimension (WxDxH)		mm	1150 × 460 × 1350	1150 × 460 × 1600	990 × 880 × 1772	1290 × 880 × 1950
	Net Weight		kg	158	185	227	293
	Gas		Inch	1	1	9/8	9/8
Liquid		Inch	3/8	3/8	1/2	5/8	

Note:

- The cooling (heating) capacity stated above is measured under following conditions
- Indoor Conditions:27°C (81 °F)DB/19°C (66.6 °F)WB; Outdoor Conditions:35°C (95.4 °F)DB/24°C (75.6 °F)WB;
- Corresponding to standard external static pressure.
- Noise is tested in the semi-anechoic room, so it should be slightly higher in the actual operation due to environmental change.
- The air volume is measured at the relevant standard external static pressure.
- The technical parameters are changed along with the products improvement; please refer to the nameplate of the unit for actual data.



4.2 Working Range

Appendix:

Air conditioner working range condition:

Test condition	Working range
	DBT°C (°F)
Cooling	-18°C ~43°C (64.8 °F ~109.8 °F)
	-18°C ~43°C (64.8 °F ~109.8 °F) (low-ambient cooling)
Heating	-7°C ~24°C (19.8 °F ~75.6 °F)



4.3 Cooling Performance

1.FG20/BNa-M,FGR20/BNa-M																	
Air Flow Rate		ESP		Outdoor Air Dry Bulb Temperature 77 °F (25°C)													
				Indoor Air Wet Bulb Temperature °F (°C)													
				Entering 62 °F (17°C) Air DBT						67 °F (19°C)				72 °F (22°C)			
				Total Capacity				Sensible Capacity		Total Capacity		Sensible Capacity		Total Capacity		Sensible Capacity	
m³/hr	cfm	Pa	in.wg	°C	°F	kW	kbtu/h	kW	kbtu/h	kW	kbtu/h	kW	kbtu/h	kW	kbtu/h	kW	kbtu/h
4154	2445	70	0.28	23	73.4	18.88	64.41	13.45	45.89	21.91	74.77	13.31	45.43	22.56	76.99	11.26	38.43
				24	75.2	19.05	65.00	15.37	52.45	22.13	75.52	14.16	48.32	22.80	77.78	12.52	42.70
				27	80.6	19.43	66.30	15.08	51.46	22.33	76.19	14.91	50.88	23.01	78.50	13.77	46.98
				31	87.6	19.70	67.22	15.72	53.64	22.55	76.94	15.50	52.89	23.23	79.25	15.07	51.42
4000	2354	90	0.36	23	73.4	18.60	63.46	13.25	45.21	21.59	73.66	13.12	44.76	22.23	75.85	11.10	37.87
				24	75.2	18.77	64.04	15.15	51.68	21.81	74.40	13.95	47.60	22.46	76.63	12.33	42.07
				27	80.6	19.14	65.32	14.86	50.70	22.00	75.06	14.69	50.13	22.67	77.34	13.57	46.29
				31	87.6	19.41	66.23	15.49	52.85	22.22	75.81	15.27	52.11	22.88	78.08	14.85	50.66
3813	2244	110	0.44	23	73.4	18.32	62.51	13.05	44.53	21.26	72.56	12.92	44.08	21.90	74.71	10.93	37.30
				24	75.2	18.49	63.08	14.92	50.90	21.48	73.29	13.74	46.89	22.12	75.48	12.15	41.44
				27	80.6	18.86	64.34	14.64	49.94	21.67	73.94	14.47	49.38	22.33	76.18	13.36	45.59
				31	87.6	19.12	65.24	15.26	52.06	21.88	74.67	15.04	51.33	22.54	76.91	14.62	49.90

FG20/BNa-M,FGR20/BNa-M

Air Flow Rate		ESP		Entering Air DBT		Outdoor Air Dry Bulb Temperature 95 °F (35 °C)											
						Indoor Air Wet Bulb Temperature °F (°C)											
						62 °F (17 °C)		67 °F (19 °C)		72 °F (22 °C)							
						Total Capacity		Sensible Capacity		Total Capacity		Sensible Capacity		Total Capacity		Sensible Capacity	
m³/hr	cfm	Pa	in.wg	°C	°F	kW	kbtu/h	kW	kbtu/h	kW	kbtu/h	kW	kbtu/h	kW	kbtu/h	kW	kbtu/h
4154	2445	70	0.28	23	73.4	17.16	58.56	12.23	41.71	19.92	67.97	12.10	41.30	20.51	69.99	10.24	34.94
				24	75.2	17.32	59.09	13.98	47.68	20.12	68.65	12.87	43.92	20.72	70.71	11.38	38.82
				27	80.6	17.67	60.27	13.71	46.78	20.30	69.26	13.56	46.25	20.92	71.36	12.52	42.71
				31	87.6	17.91	61.11	14.29	48.77	20.50	69.95	14.09	48.08	21.12	72.05	13.70	46.74
4000	2354	90	0.36	23	73.4	16.91	57.69	12.05	41.10	19.63	66.96	11.92	40.69	20.21	68.96	10.09	34.42
				24	75.2	17.06	58.22	13.77	46.98	19.82	67.64	12.68	43.28	20.42	69.67	11.21	38.25
				27	80.6	17.40	59.38	13.51	46.09	20.00	68.24	13.36	45.57	20.61	70.31	12.33	42.08
				31	87.6	17.65	60.21	14.08	48.05	20.20	68.92	13.88	47.37	20.80	70.98	13.50	46.05
3813	2244	110	0.44	23	73.4	16.65	56.82	11.86	40.48	19.33	65.96	11.75	40.08	19.91	67.92	9.94	33.91
				24	75.2	16.81	57.34	13.56	46.28	19.53	66.62	12.49	42.63	20.11	68.62	11.04	37.67
				27	80.6	17.14	58.49	13.31	45.40	19.70	67.22	13.16	44.89	20.30	69.25	12.15	41.45
				31	87.6	17.38	59.31	13.87	47.33	19.90	67.88	13.68	46.66	20.49	69.92	13.30	45.36

FG20/BNa-M,FGR20/BNa-M

Air Flow Rate		ESP		Entering Air DBT		Outdoor Air Dry Bulb Temperature 115 °F (46°C)											
						Indoor Air Wet Bulb Temperature °F (°C)											
						62 °F (17°C)				67 °F (19°C)				72 °F (22°C)			
						Total Capacity		Sensible Capacity		Total Capacity		Sensible Capacity		Total Capacity		Sensible Capacity	
m³/hr	cfm	Pa	in.wg	°C	°F	kW	kbtu/h	kW	kbtu/h	kW	kbtu/h	kW	kbtu/h	kW	kbtu/h	kW	kbtu/h
4154	2445	70	0.28	23	73.4	15.55	53.07	11.19	38.18	17.04	58.14	11.23	38.33	18.72	63.89	9.42	32.15
				24	75.2	15.70	53.57	12.81	43.70	17.22	58.75	11.96	40.80	18.92	64.54	10.46	35.70
				27	80.6	16.01	54.64	12.56	42.86	17.37	59.28	12.58	42.94	19.09	65.15	11.52	39.32
				31	87.6	17.35	59.21	13.09	44.65	17.54	59.85	13.09	44.65	19.28	65.79	12.61	43.01
4000	2354	90	0.36	23	73.4	15.32	52.29	11.02	37.61	16.79	57.28	11.07	37.76	18.45	62.94	9.28	31.68
				24	75.2	15.47	52.78	12.62	43.05	16.96	57.88	11.78	40.20	18.64	63.59	10.31	35.17
				27	80.6	15.78	53.83	12.38	42.23	17.12	58.41	12.40	42.30	18.81	64.19	11.35	38.74
				31	87.6	17.10	58.33	12.89	43.99	17.28	58.97	12.89	43.99	19.00	64.82	12.42	42.38
3813	2244	110	0.44	23	73.4	15.09	51.50	10.86	37.05	16.54	56.42	10.90	37.20	18.17	62.00	9.14	31.20
				24	75.2	15.24	51.99	12.43	42.41	16.71	57.01	11.61	39.60	18.36	62.63	10.15	34.64
				27	80.6	15.54	53.02	12.19	41.59	16.86	57.53	12.21	41.67	18.53	63.22	11.18	38.16
				31	87.6	16.84	57.46	12.70	43.33	17.02	58.08	12.70	43.33	18.71	63.85	12.23	41.74

FG20/BNa-M,FGR20/BNa-M

Air Flow Rate		ESP		Entering Air DBT		Outdoor Air Dry Bulb Temperature 125 °F (52°C)											
						Indoor Air Wet Bulb Temperature °F (°C)											
						62 °F (17°C)				67 °F (19°C)				72 °F (22°C)			
						Total Capacity		Sensible Capacity		Total Capacity		Sensible Capacity		Total Capacity		Sensible Capacity	
m³/hr	cfm	Pa	in.wg	°C	°F	kW	kbtu/h	kW	kbtu/h	kW	kbtu/h	kW	kbtu/h	kW	kbtu/h	kW	kbtu/h
4154	2445	70	0.28	23	73.4	14.47	49.38	10.53	35.93	15.84	54.06	10.57	36.08	17.42	59.44	8.87	30.25
				24	75.2	14.61	49.84	12.05	41.11	16.01	54.64	11.26	38.41	17.60	60.04	9.85	33.60
				27	80.6	14.90	50.83	11.82	40.35	16.16	55.13	11.85	40.42	17.75	60.58	10.84	36.99
				31	87.6	15.10	51.51	12.32	42.02	16.31	55.66	12.32	42.02	17.93	61.19	11.86	40.46
4000	2354	90	0.36	23	73.4	14.26	48.65	10.37	35.40	15.61	53.26	10.42	35.55	17.16	58.56	8.73	29.80
				24	75.2	14.39	49.10	11.87	40.50	15.78	53.83	11.09	37.84	17.34	59.16	9.70	33.10
				27	80.6	14.68	50.07	11.65	39.75	15.92	54.31	11.67	39.82	17.49	59.68	10.68	36.45
				31	87.6	14.87	50.75	12.13	41.40	16.07	54.84	12.13	41.40	17.67	60.28	11.68	39.87
3813	2244	110	0.44	23	73.4	14.04	47.92	10.22	34.87	15.38	52.46	10.26	35.01	16.90	57.68	8.60	29.35
				24	75.2	14.17	48.36	11.69	39.89	15.54	53.02	10.92	37.27	17.08	58.27	9.56	32.61
				27	80.6	14.46	49.32	11.48	39.15	15.68	53.50	11.50	39.23	17.23	58.79	10.52	35.90
				31	87.6	14.65	49.99	11.95	40.78	15.83	54.02	11.95	40.78	17.40	59.38	11.51	39.27

2.FG25/BNa-M,FGR25/BNa-M

Air Flow Rate		ESP		Entering Air DBT		Outdoor Air Dry Bulb Temperature 77 °F (25°C)											
						Indoor Air Wet Bulb Temperature °F (°C)											
						62 °F (17°C)		67 °F (19°C)		72 °F (22°C)							
						Total Capacity		Sensible Capacity		Total Capacity		Sensible Capacity		Total Capacity		Sensible Capacity	
m³/hr	cfm	Pa	in.wg	°C	°F	kW	kbtu/h	kW	kbtu/h	kW	kbtu/h	kW	kbtu/h	kW	kbtu/h	kW	kbtu/h
4154	2445	70	0.28	23	73.4	23.12	78.90	16.47	56.21	26.84	91.58	16.31	55.65	27.64	94.31	13.80	47.08
				24	75.2	23.33	79.62	18.83	64.25	27.11	92.51	17.35	59.19	27.92	95.28	15.33	52.31
				27	80.6	23.80	81.21	18.48	63.04	27.35	93.33	18.27	62.32	28.18	96.16	16.87	57.55
				31	87.6	24.13	82.34	19.26	65.71	27.62	94.25	18.99	64.79	28.45	97.08	18.46	62.99
4000	2354	90	0.36	23	73.4	22.78	77.73	16.23	55.38	26.44	90.23	16.07	54.82	27.23	92.91	13.59	46.38
				24	75.2	22.99	78.44	18.55	63.30	26.71	91.14	17.09	58.31	27.51	93.87	15.10	51.54
				27	80.6	23.45	80.01	18.20	62.11	26.95	91.95	18.00	61.40	27.77	94.74	16.62	56.70
				31	87.6	23.78	81.13	18.97	64.74	27.22	92.86	18.71	63.83	28.03	95.65	18.19	62.05
3813	2244	110	0.44	23	73.4	22.44	76.57	15.99	54.55	26.05	88.88	15.83	54.00	26.82	91.52	13.39	45.69
				24	75.2	22.65	77.27	18.27	62.35	26.31	89.77	16.83	57.44	27.10	92.46	14.88	50.76
				27	80.6	23.10	78.81	17.93	61.18	26.54	90.57	17.73	60.48	27.35	93.31	16.37	55.85
				31	87.6	23.42	79.91	18.69	63.77	26.81	91.47	18.43	62.87	27.61	94.21	17.91	61.12

FG25/BNa-M,FGR25/BNa-M

Air Flow Rate		ESP		Entering Air DBT		Outdoor Air Dry Bulb Temperature 95 °F (35°C)											
						Indoor Air Wet Bulb Temperature °F (°C)											
						62 °F (17°C)		67 °F (19°C)		72 °F (22°C)							
						Total Capacity	Sensible Capacity	Total Capacity	Sensible Capacity	Total Capacity	Sensible Capacity	Total Capacity	Sensible Capacity	Total Capacity	Sensible Capacity	Total Capacity	Sensible Capacity
m³/hr	cfm	Pa	in.wg	°C	°F	kW	kbtu/h	kW	kbtu/h	kW	kbtu/h	kW	kbtu/h	kW	kbtu/h	kW	kbtu/h
4154	2445	70	0.28	23	73.4	21.02	71.73	14.98	51.10	24.40	83.26	14.83	50.59	25.13	85.73	12.54	42.80
				24	75.2	21.21	72.38	17.12	58.41	24.65	84.10	15.77	53.81	25.39	86.62	13.94	47.55
				27	80.6	21.64	73.83	16.80	57.31	24.87	84.84	16.61	56.66	25.62	87.41	15.33	52.32
				31	87.6	21.94	74.86	17.51	59.74	25.11	85.68	17.26	58.90	25.87	88.25	16.78	57.26
4000	2354	90	0.36	23	73.4	20.71	70.67	14.75	50.34	24.04	82.03	14.61	49.84	24.76	84.47	12.36	42.17
				24	75.2	20.90	71.31	16.87	57.55	24.28	82.85	15.54	53.01	25.01	85.34	13.73	46.85
				27	80.6	21.32	72.74	16.55	56.46	24.50	83.59	16.36	55.82	25.24	86.12	15.11	51.54
				31	87.6	21.62	73.75	17.25	58.85	24.74	84.42	17.01	58.03	25.48	86.95	16.53	56.41
3813	2244	110	0.44	23	73.4	20.40	69.61	14.53	49.59	23.68	80.80	14.39	49.09	24.38	83.20	12.17	41.53
				24	75.2	20.59	70.24	16.61	56.68	23.92	81.61	15.30	52.22	24.64	84.06	13.52	46.15
				27	80.6	21.00	71.65	16.30	55.61	24.13	82.34	16.11	54.98	24.86	84.83	14.88	50.77
				31	87.6	21.29	72.65	16.99	57.97	24.37	83.15	16.75	57.16	25.10	85.65	16.29	55.57

FG25/BNa-M,FGR25/BNa-M

Air Flow Rate		ESP		Entering Air DBT		Outdoor Air Dry Bulb Temperature 115 °F (46°C)											
						Indoor Air Wet Bulb Temperature °F (°C)											
						62 °F (17°C)				67 °F (19°C)				72 °F (22°C)			
						Total Capacity		Sensible Capacity		Total Capacity		Sensible Capacity		Total Capacity		Sensible Capacity	
m³/hr	cfm	Pa	in.wg	°C	°F	kW	kbtu/h	kW	kbtu/h	kW	kbtu/h	kW	kbtu/h	kW	kbtu/h	kW	kbtu/h
4154	2445	70	0.28	23	73.4	19.05	65.01	13.71	46.77	20.87	71.22	13.76	46.95	22.94	78.26	11.54	39.38
				24	75.2	19.23	65.62	15.69	53.53	21.09	71.96	14.65	49.98	23.17	79.06	12.82	43.73
				27	80.6	19.61	66.92	15.39	52.50	21.28	72.62	15.41	52.59	23.39	79.80	14.12	48.17
				31	87.6	21.26	72.52	16.03	54.70	21.49	73.31	16.03	54.70	23.62	80.59	15.44	52.69
		90	0.36	23	73.4	18.77	64.05	13.50	46.07	20.56	70.17	13.56	46.26	22.60	77.10	11.37	38.80
				24	75.2	18.95	64.65	15.46	52.74	20.78	70.90	14.43	49.24	22.83	77.89	12.63	43.08
				27	80.6	19.32	65.94	15.16	51.73	20.97	71.54	15.19	51.82	23.04	78.62	13.91	47.45
				31	87.6	20.94	71.45	15.79	53.89	21.17	72.23	15.79	53.89	23.27	79.40	15.21	51.91
3813	2244	110	0.44	23	73.4	18.49	63.09	13.30	45.38	20.26	69.11	13.35	45.56	22.26	75.95	11.20	38.22
				24	75.2	18.66	63.68	15.22	51.95	20.47	69.84	14.22	48.50	22.49	76.72	12.44	42.44
				27	80.6	19.03	64.95	14.93	50.95	20.65	70.47	14.96	51.04	22.70	77.45	13.70	46.74
				31	87.6	20.63	70.38	15.56	53.08	20.85	71.15	15.56	53.08	22.92	78.21	14.99	51.13

FG25/BNa-M,FGR25/BNa-M

Air Flow Rate		ESP		Entering Air DBT		Outdoor Air Dry Bulb Temperature 125 °F (52°C)											
						Indoor Air Wet Bulb Temperature °F (°C)											
						62 °F (17°C)				67 °F (19°C)				72 °F (22°C)			
						Total Capacity		Sensible Capacity		Total Capacity		Sensible Capacity		Total Capacity		Sensible Capacity	
m³/hr	cfm	Pa	in.wg	°C	°F	kW	kbtu/h	kW	kbtu/h	kW	kbtu/h	kW	kbtu/h	kW	kbtu/h	kW	kbtu/h
4154	2445	70	0.28	23	73.4	17.73	60.49	12.90	44.01	19.41	66.22	12.95	44.20	21.34	72.80	10.86	37.05
				24	75.2	17.89	61.05	14.76	50.35	19.61	66.92	13.79	47.05	21.56	73.55	12.06	41.16
				27	80.6	18.25	62.26	14.48	49.42	19.79	67.53	14.51	49.51	21.75	74.20	13.28	45.32
				31	87.6	18.49	63.10	15.09	51.47	19.98	68.18	15.09	51.47	21.97	74.95	14.53	49.57
4000	2354	90	0.36	23	73.4	17.47	59.59	12.71	43.36	19.12	65.24	12.76	43.54	21.02	71.73	10.70	36.50
				24	75.2	17.63	60.14	14.54	49.61	19.32	65.94	13.58	46.35	21.24	72.46	11.88	40.55
				27	80.6	17.98	61.34	14.27	48.69	19.50	66.53	14.30	48.78	21.43	73.11	13.08	44.65
				31	87.6	18.22	62.17	14.86	50.71	19.69	67.17	14.86	50.71	21.64	73.84	14.31	48.83
3813	2244	110	0.44	23	73.4	17.20	58.70	12.52	42.71	18.83	64.26	12.57	42.89	20.71	70.65	10.54	35.96
				24	75.2	17.36	59.24	14.32	48.87	19.03	64.95	13.38	45.66	20.92	71.38	11.71	39.94
				27	80.6	17.71	60.42	14.06	47.96	19.21	65.53	14.08	48.05	21.11	72.01	12.89	43.98
				31	87.6	17.95	61.23	14.64	49.95	19.39	66.17	14.64	49.95	21.32	72.74	14.10	48.10

3.FG30/BNa-M,FGR30/BNa-M

Air Flow Rate		ESP		Entering Air DBT		Outdoor Air Dry Bulb Temperature 77 °F (25°C)											
						Indoor Air Wet Bulb Temperature °F (°C)											
						62 °F (17°C)				67 °F (19°C)				72 °F (22°C)			
						Total Capacity		Sensible Capacity		Total Capacity		Sensible Capacity		Total Capacity		Sensible Capacity	
m³/hr	cfm	Pa	in.wg	°C	°F	kW	kbtu/h	kW	kbtu/h	kW	kbtu/h	kW	kbtu/h	kW	kbtu/h	kW	kbtu/h
4154	2445	70	0.28	23	73.4	28.32	96.62	20.17	68.83	32.87	112.15	19.97	68.14	33.85	115.48	16.90	57.65
				24	75.2	28.57	97.50	23.06	78.68	33.20	113.28	21.24	72.48	34.20	116.67	18.77	64.05
				27	80.6	29.15	99.45	22.62	77.19	33.50	114.28	22.37	76.32	34.51	117.75	20.65	70.47
				31	87.6	29.55	100.83	23.58	80.47	33.83	115.42	23.25	79.34	34.84	118.88	22.61	77.13
4000	2354	90	0.36	23	73.4	27.90	95.19	19.87	67.81	32.38	110.49	19.68	67.13	33.35	113.78	16.65	56.80
				24	75.2	28.15	96.06	22.72	77.52	32.71	111.61	20.93	71.40	33.69	114.95	18.50	63.11
				27	80.6	28.72	97.98	22.29	76.05	33.00	112.60	22.04	75.19	34.00	116.01	20.35	69.43
				31	87.6	29.12	99.34	23.23	79.28	33.33	113.71	22.91	78.16	34.33	117.12	22.27	75.99
3813	2244	110	0.44	23	73.4	27.48	93.76	19.58	66.80	31.90	108.83	19.38	66.13	32.85	112.07	16.40	55.95
				24	75.2	27.73	94.61	22.38	76.35	32.22	109.93	20.61	70.33	33.18	113.23	18.22	62.16
				27	80.6	28.29	96.51	21.96	74.91	32.51	110.91	21.71	74.06	33.49	114.27	20.04	68.39
				31	87.6	28.68	97.85	22.89	78.09	32.83	112.01	22.57	76.99	33.81	115.37	21.94	74.85

FG30/BNa-M,FGR30/BNa-M

Air Flow Rate		ESP		Entering Air DBT		Outdoor Air Dry Bulb Temperature 95 °F (35°C)											
						Indoor Air Wet Bulb Temperature °F (°C)											
						62 °F (17°C)				67 °F (19°C)				72 °F (22°C)			
						Total Capacity		Sensible Capacity		Total Capacity		Sensible Capacity		Sensible Capacity		Total Capacity	
m³/hr	cfm	Pa	in.wg	°C	°F	kW	kbtu/h	kW	kbtu/h	kW	kbtu/h	kW	kbtu/h	kW	kbtu/h	kW	kbtu/h
4154	2445	70	0.28	23	73.4	25.74	87.83	18.34	62.57	29.88	101.95	18.16	61.95	30.77	104.99	15.36	52.41
				24	75.2	25.98	88.63	20.96	71.53	30.18	102.98	19.31	65.89	31.09	106.07	17.07	58.23
				27	80.6	26.50	90.41	20.57	70.18	30.45	103.90	20.33	69.38	31.37	107.04	18.78	64.07
				31	87.6	26.87	91.67	21.44	73.15	30.75	104.92	21.14	72.12	31.67	108.07	20.55	70.12
4000	2354	90	0.36	23	73.4	25.36	86.54	18.07	61.65	29.44	100.45	17.89	61.03	30.32	103.43	15.13	51.63
				24	75.2	25.59	87.32	20.65	70.47	29.74	101.46	19.03	64.91	30.63	104.50	16.81	57.37
				27	80.6	26.11	89.07	20.26	69.14	30.00	102.36	20.03	68.36	30.91	105.46	18.50	63.12
				31	87.6	26.47	90.31	21.12	72.07	30.30	103.37	20.83	71.06	31.21	106.47	20.25	69.08
3813	2244	110	0.44	23	73.4	24.98	85.24	17.80	60.72	29.00	98.94	17.62	60.12	29.86	101.88	14.91	50.86
				24	75.2	25.21	86.01	20.34	69.41	29.29	99.94	18.74	63.94	30.17	102.93	16.56	56.51
				27	80.6	25.71	87.74	19.96	68.10	29.55	100.82	19.73	67.33	30.45	103.88	18.22	62.17
				31	87.6	26.07	88.96	20.81	70.99	29.84	101.82	20.51	69.99	30.74	104.88	19.94	68.04

4.FG40/BNa-M,FGR40/BNa-M

Air Flow Rate		ESP		Entering Air DBT		Outdoor Air Dry Bulb Temperature 77 °F (25°C)											
						Indoor Air Wet Bulb Temperature °F (°C)											
						62 °F (17°C)				67 °F (19°C)				72 °F (22°C)			
						Total Capacity		Sensible Capacity		Total Capacity		Sensible Capacity		Total Capacity		Sensible Capacity	
m³/hr	cfm	Pa	in.wg	°C	°F	kW	kbtu/h	kW	kbtu/h	kW	kbtu/h	kW	kbtu/h	kW	kbtu/h	kW	kbtu/h
4154	2445	70	0.28	23	73.4	37.28	127.21	26.56	90.62	43.28	147.66	26.29	89.72	44.56	152.05	22.25	75.90
				24	75.2	37.62	128.37	30.36	103.59	43.71	149.15	27.97	95.42	45.02	153.62	24.72	84.33
				27	80.6	38.38	130.94	29.79	101.64	44.10	150.47	29.45	100.48	45.44	155.03	27.19	92.79
				31	87.6	38.91	132.76	31.05	105.94	44.54	151.96	30.61	104.46	45.87	156.52	29.76	101.55
4000	2354	90	0.36	23	73.4	36.73	125.33	26.17	89.28	42.64	145.47	25.91	88.39	43.90	149.80	21.92	74.78
				24	75.2	37.07	126.47	29.91	102.06	43.07	146.94	27.55	94.01	44.36	151.35	24.35	83.09
				27	80.6	37.81	129.00	29.35	100.13	43.45	148.25	29.02	99.00	44.77	152.74	26.79	91.41
				31	87.6	38.33	130.80	30.59	104.38	43.88	149.71	30.16	102.91	45.20	154.21	29.32	100.05
3813	2244	110	0.44	23	73.4	36.18	123.45	25.78	87.94	42.00	143.29	25.52	87.06	43.25	147.56	21.59	73.66
				24	75.2	36.51	124.57	29.46	100.53	42.42	144.74	27.14	92.60	43.69	149.08	23.99	81.84
				27	80.6	37.24	127.07	28.91	98.63	42.80	146.02	28.58	97.51	44.09	150.45	26.39	90.04
				31	87.6	37.76	128.84	30.13	102.81	43.22	147.47	29.71	101.37	44.52	151.89	28.88	98.55

FG40/BNa-M,FGR40/BNa-M

Air Flow Rate		ESP		Entering Air DBT		Outdoor Air Dry Bulb Temperature 115 °F (46°C)											
						Indoor Air Wet Bulb Temperature °F (°C)											
						62 °F (17°C)				67 °F (19°C)				72 °F (22°C)			
						Total Capacity		Sensible Capacity		Total Capacity		Sensible Capacity		Sensible Capacity		Total Capacity	
m³/hr	cfm	Pa	in.wg	°C	°F	kW	kbtu/h	kW	kbtu/h	kW	kbtu/h	kW	kbtu/h	kW	kbtu/h	kW	kbtu/h
4154	2445	70	0.28	23	73.4	30.72	104.81	22.10	75.40	33.65	114.82	22.19	75.70	36.98	126.18	18.61	63.50
				24	75.2	31.01	105.79	25.29	86.30	34.01	116.03	23.62	80.58	37.36	127.46	20.66	70.50
				27	80.6	31.62	107.90	24.81	84.65	34.31	117.08	24.85	84.80	37.71	128.67	22.76	77.66
				31	87.6	34.27	116.93	25.85	88.19	34.64	118.20	25.85	88.19	38.08	129.94	24.90	84.95
4000	2354	90	0.36	23	73.4	30.26	103.26	21.77	74.29	33.16	113.13	21.86	74.58	36.43	124.31	18.34	62.56
				24	75.2	30.55	104.23	24.92	85.03	33.50	114.31	23.27	79.39	36.81	125.58	20.36	69.46
				27	80.6	31.16	106.31	24.44	83.40	33.81	115.35	24.49	83.54	37.15	126.76	22.42	76.51
				31	87.6	33.76	115.20	25.46	86.89	34.13	116.45	25.46	86.89	37.52	128.02	24.53	83.69
3813	2244	110	0.44	23	73.4	29.81	101.71	21.45	73.17	32.66	111.43	21.53	73.46	35.89	122.45	18.06	61.62
				24	75.2	30.09	102.67	24.55	83.75	33.00	112.60	22.92	78.20	36.25	123.70	20.05	68.42
				27	80.6	30.69	104.71	24.08	82.14	33.30	113.62	24.12	82.29	36.60	124.86	22.09	75.36
				31	87.6	33.26	113.47	25.08	85.58	33.62	114.71	25.08	85.58	36.96	126.10	24.16	82.44

FG40/BNa-M, FGR40/BNa-M

Air Flow Rate		ESP		Entering Air DBT		Outdoor Air Dry Bulb Temperature 125 °F (52°C)											
						Indoor Air Wet Bulb Temperature °F (°C)											
m³/hr		cfm		Pa		in.wg		62 °F (17°C)		67 °F (19°C)		72 °F (22°C)					
								Total Capacity		Sensible Capacity		Total Capacity		Sensible Capacity		Sensible Capacity	
4154	2445	70	0.28	23	73.4	28.58	97.52	20.80	70.95	31.29	106.77	20.88	71.25	34.40	117.38	17.51	59.74
				24	75.2	28.85	98.42	23.79	81.19	31.62	107.90	22.23	75.85	34.76	118.58	19.45	66.36
				27	80.6	29.42	100.38	23.35	79.68	31.91	108.87	23.40	79.83	35.06	119.64	21.41	73.06
				31	87.6	29.82	101.73	24.32	82.99	32.22	109.93	24.32	82.99	35.42	120.84	23.42	79.91
4000	2354	90	0.36	23	73.4	28.16	96.08	20.49	69.91	30.83	105.19	20.57	70.20	33.89	115.65	17.25	58.85
				24	75.2	28.42	96.97	23.44	79.99	31.16	106.31	21.90	74.73	34.24	116.83	19.16	65.38
				27	80.6	28.98	98.89	23.01	78.50	31.44	107.26	23.05	78.65	34.55	117.87	21.10	71.98
				31	87.6	29.38	100.23	23.96	81.76	31.74	108.30	23.96	81.76	34.89	119.06	23.08	78.73
3813	2244	110	0.44	23	73.4	27.74	94.64	20.18	68.86	30.37	103.61	20.27	69.15	33.39	113.91	16.99	57.97
				24	75.2	27.99	95.51	23.09	78.79	30.69	104.71	21.57	73.61	33.73	115.08	18.87	64.40
				27	80.6	28.55	97.41	22.66	77.33	30.97	105.65	22.71	77.47	34.03	116.10	20.78	70.90
				31	87.6	28.93	98.73	23.60	80.54	31.27	106.68	23.60	80.54	34.37	117.27	22.73	77.55

 **4.4 Electrical Data**

Model	Compressor				Fan Motor		Max. Fuse Breaker Size	Min. Disconnect Size
	Power Supply	Qty.	RLA	LRA	Condenser Fan Motors	Supply Blower Motor		
			Each	Each	FLA Each	FLA Each	Amperes	Amperes
FG(R)20/BNa-M	380-415V 3N~50HZ	1	15.7	92	1.3	2.6	10/25	3.3/21
FG(R)25/BNa-M	380-415V 3N~50HZ	1	16.4	142	1.3	5.16	10/32	6.5/21.8
FG(R)30/BNa-M	380-415V 3N~50HZ	1	20.7	130	1.5	3.7	10/40	4.6/27.4
FG(R)40/BNa-M	380-415V 3N~50HZ	1	27.6	197	2.5	5.16	10/40	6.5/36.7

5 FAN CHARACTERISTICS

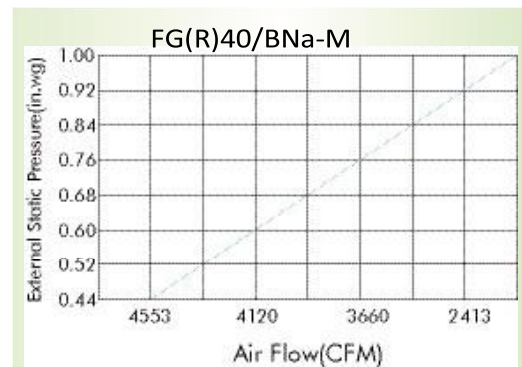
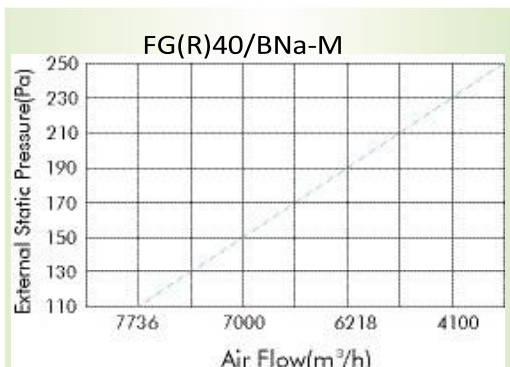
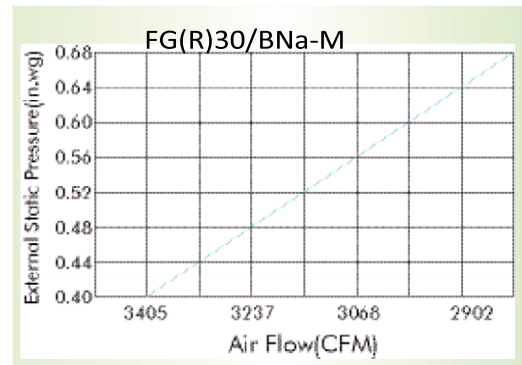
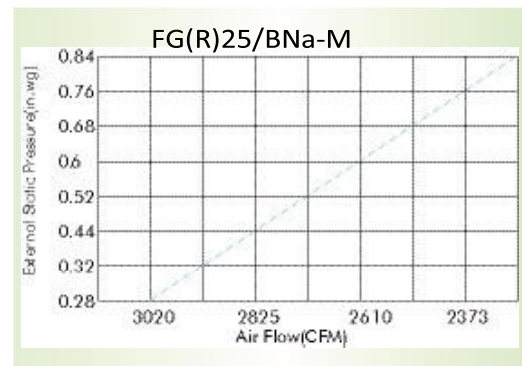
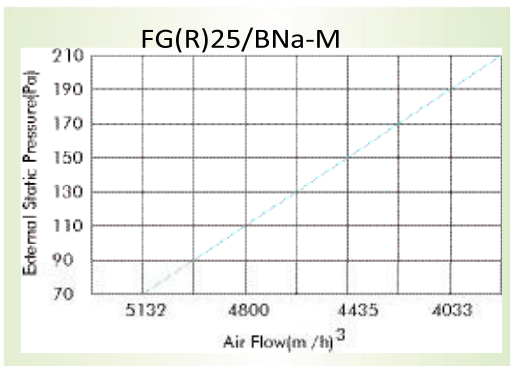
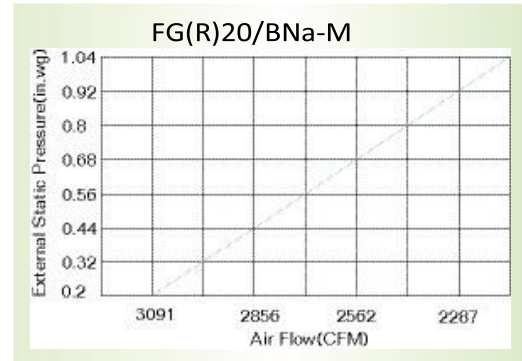
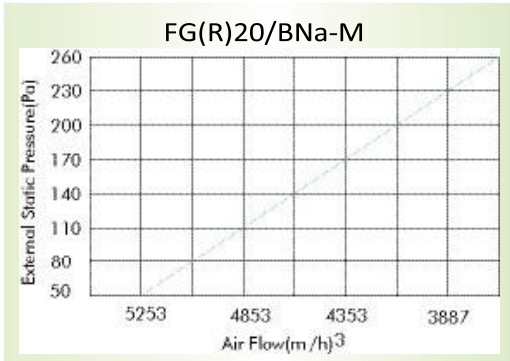

6 CLEARANCE DATA

➔ 6.1 Space requirement of the indoor unit

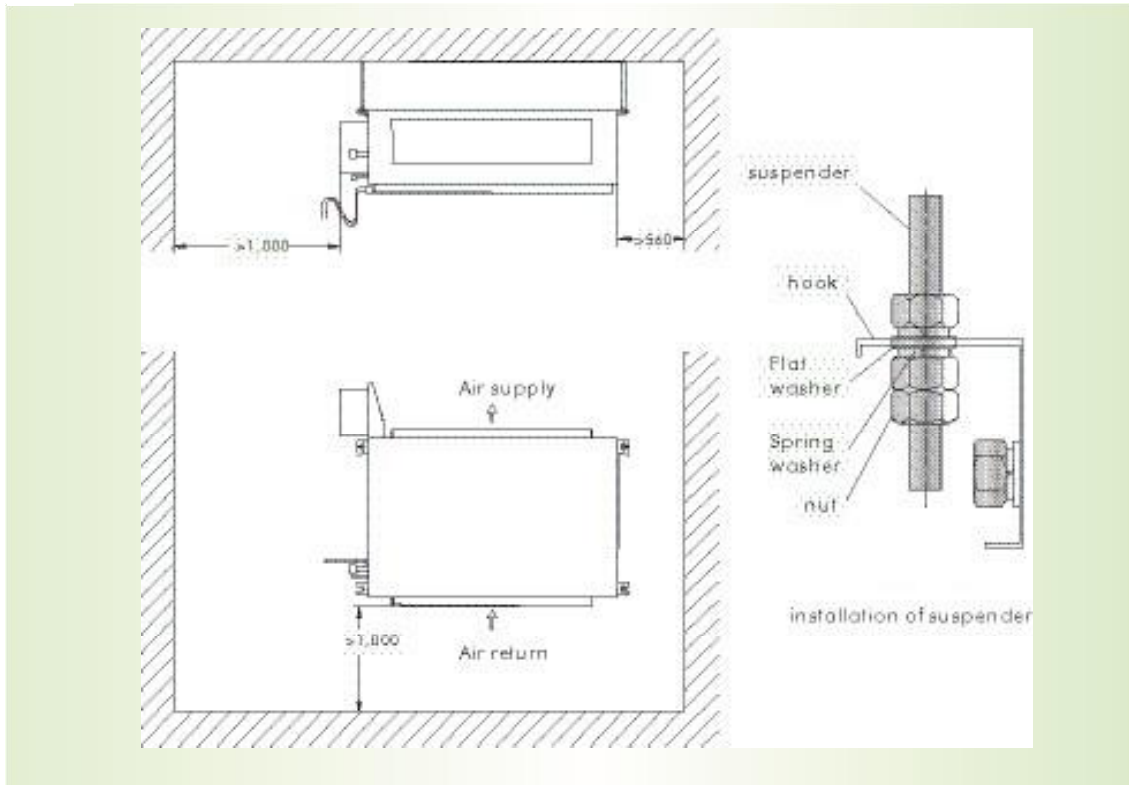

➔ 6.2 Space requirement of the outdoor unit

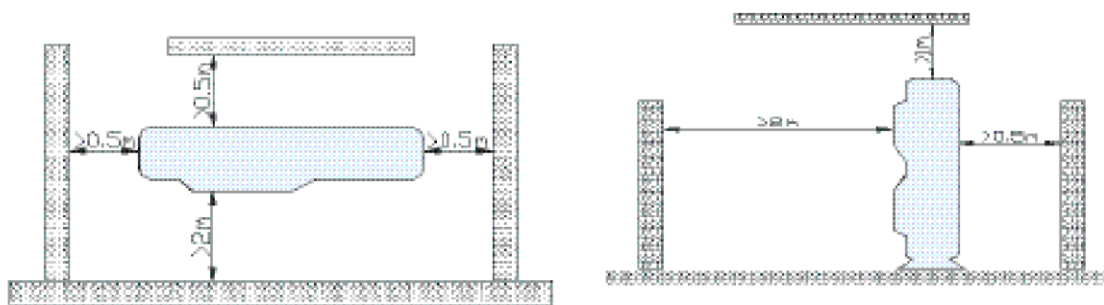

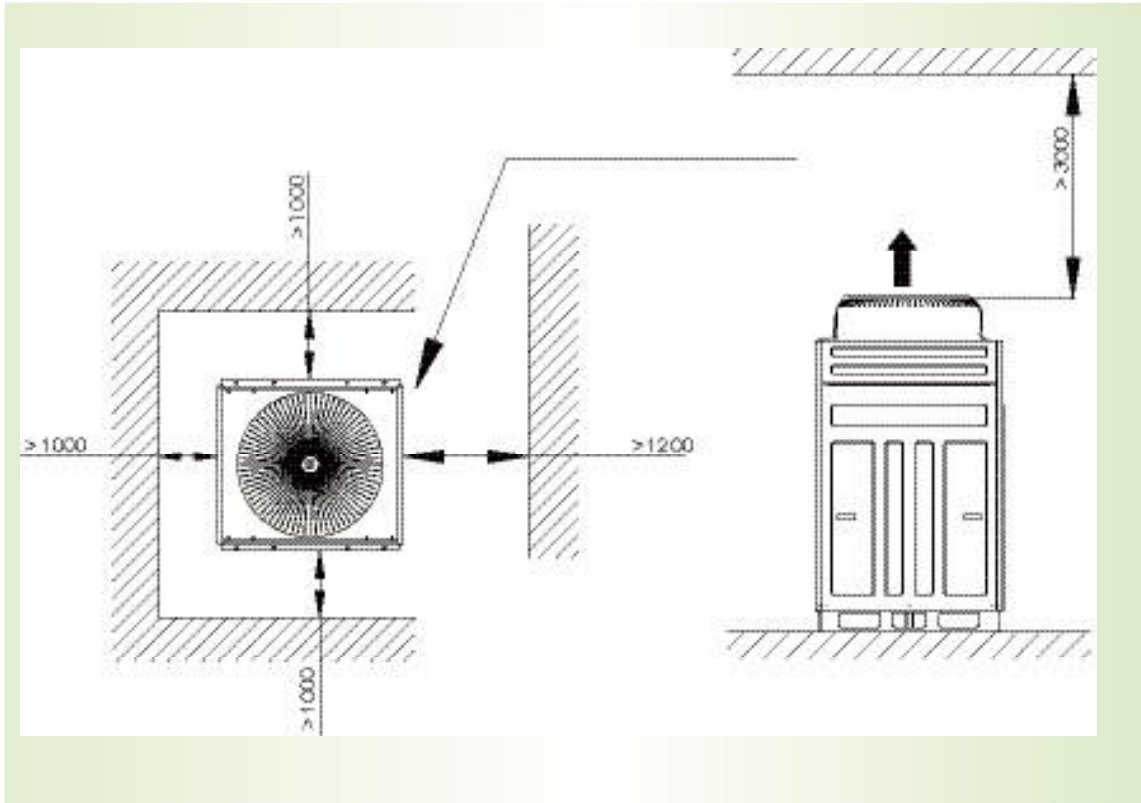

➔ **6.3 Lining position of the outdoor unit**

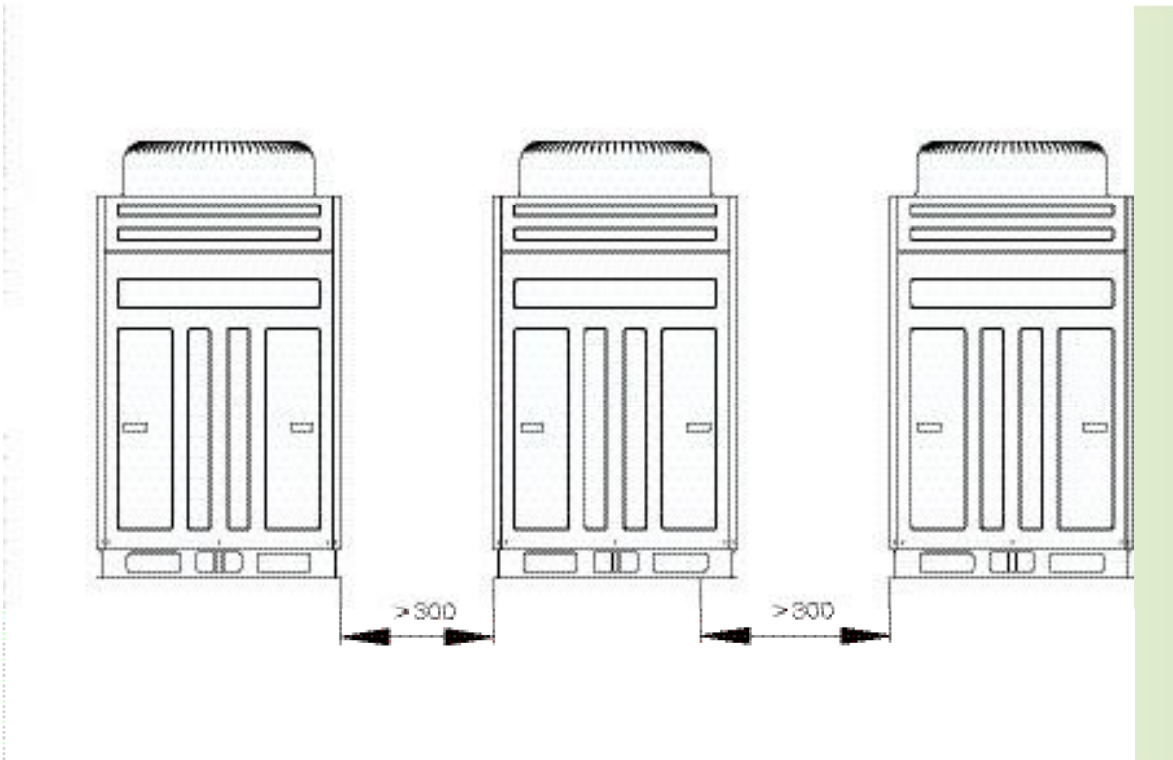

7 DIMENSIONAL DATA

➔ 7.1 Dimensional Data – Condensing Units

Unit: mm

Model	A	B	C
FG(R)20/BNa-M(O)	1150	460	1350
FG(R)25/BNa-M(O)	1150	460	1600

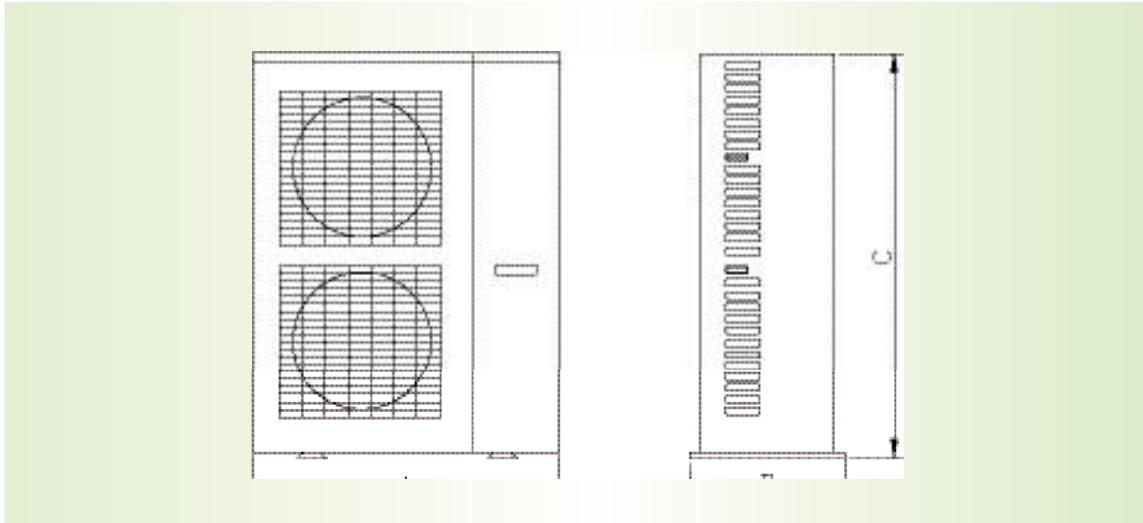

Model	A	B	C
FG(R)30/BNa-M(O)	990	787	387
FG(R)40/BNa-M(O)	1290	1160	850

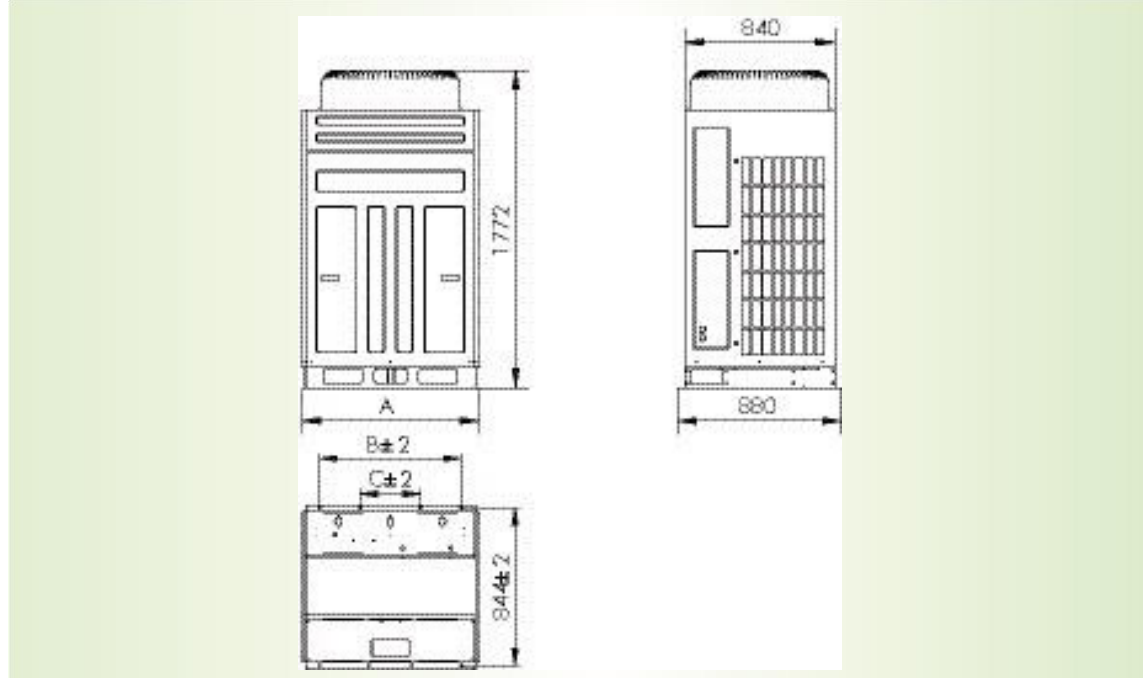

7.2 Dimensional Data – Indoor Units

Model	A	B	C	D	E	F
FG(R)20/BNa-M	1353	632	992	1150	192	343
FG(R)25/BNa-M	1560	910	332	1194	292	342
FG(R)30/BNa-M	1560	910	1194	1194	292	342

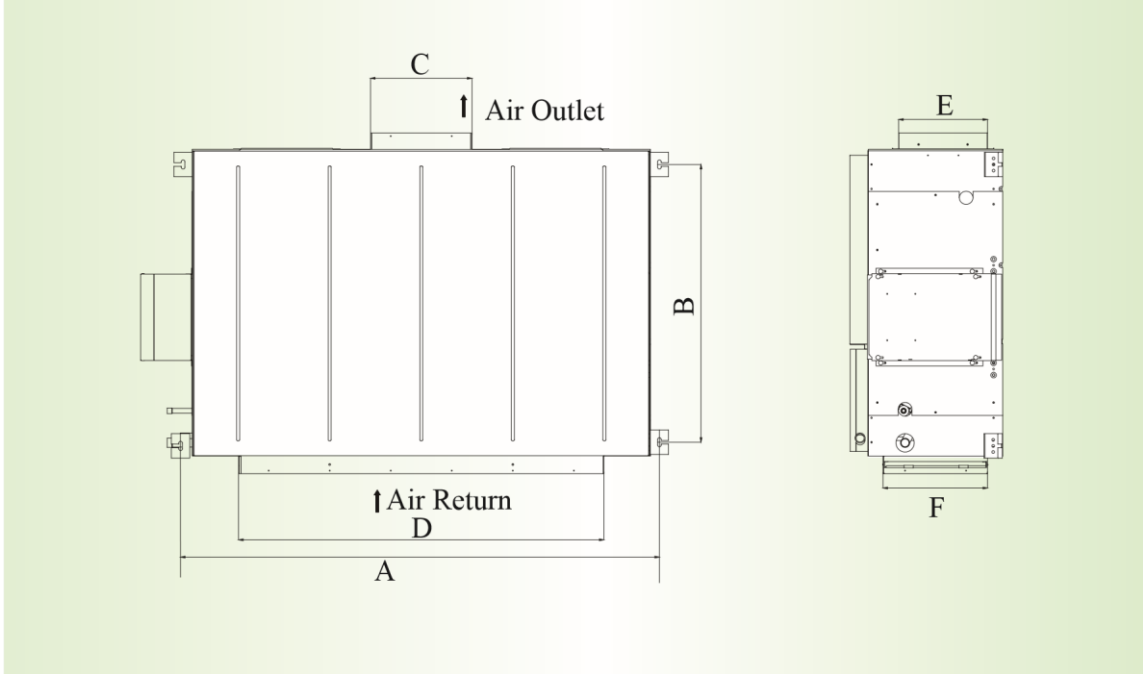

Model	A	B	C	D	E	F
FG(R)40/BNa-M	1780	1040	868	1450	347	555

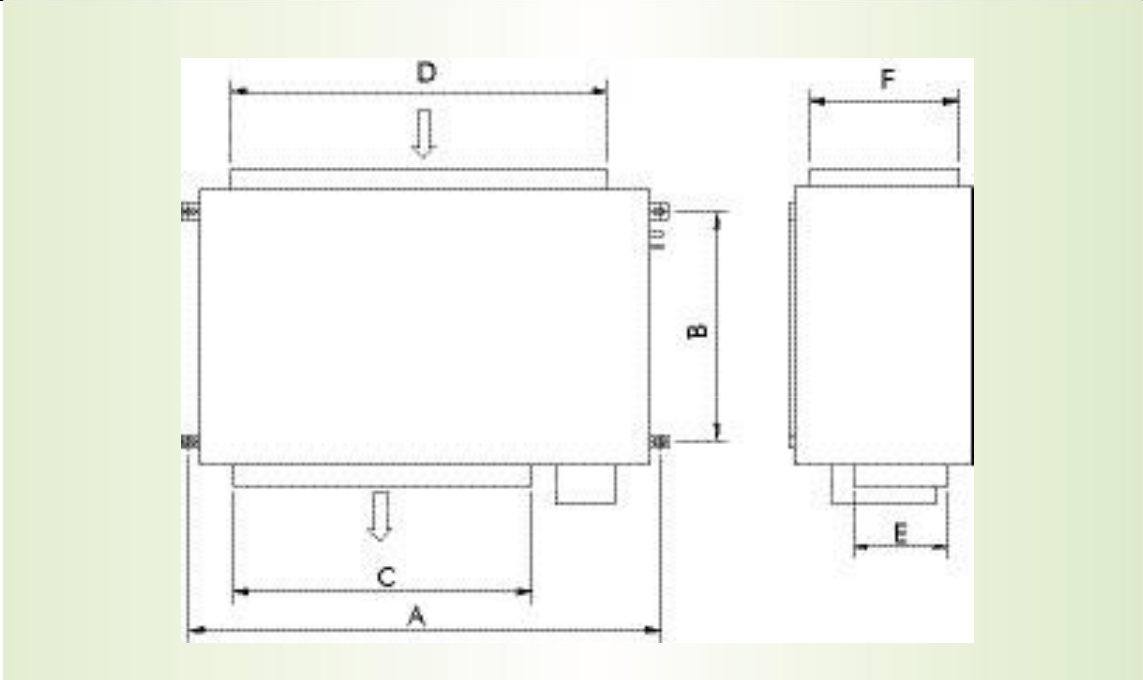

8 ACCESSORIES

Accessories name	Model name	Standard	Optional	Prepared by the user	Remark
Wired controller	Z4E351A	⊙			
Weekly timer	ZJ4011A		⊙		
Wireless controller	YB1F2		⊙		
Centralized control and weekly timer	CE50-24/E		⊙		
Flexible pipe			⊙		It is applicable to the Model 20.
Communication cable			⊙		2835 AWG24 is preferred as the communication line with a diameter of 0.5-0.75 mm ² .
Low-ambient cooling			⊙		
Connection wire of the wired controller		⊙			
Power cord	H05VV-F H05RN-F			⊙	H05VV-F with the diameter of 1.5mm ² is preferred for the indoor unit, while H05RN-F is referred for the outdoor unit, with the diameter of 4.0mm ² suitable to Model 20, 6.0mm ² to Model 25, and 10.0mm ² to Model 30 and Model 40.
Signal control line		⊙			
Motorized air valve and air vents				⊙	
Duct pipe and the connector				⊙	
Insulation material for the duct pipe				⊙	
Filter screen				⊙	The unit is equipped with a return air filter.
Connecting pipeline between indoor and outdoor units				⊙	
Drain pipe				⊙	

Con una trayectoria de más de 15 años en la Argentina, Aires del Sur nació de la fusión de capitales israelíes y nacionales, dedicándose a la fabricación y comercialización de equipamientos de aires acondicionados.

Cuenta con una fábrica de producción ubicada en Tierra del Fuego (diseñada y sistematizada con alta tecnología israelí de última generación) y con oficinas centrales en Buenos Aires.

Logramos ocupar un importante lugar en el mercado local definiendo dos líneas claras de negocio: a través del canal especialista y con los principales retailers del país. Por otro lado, ofrecemos un servicio de asesoramiento pre y post venta con profesionales especializados en instalación y repuestos.

Aires del Sur tiene como motor principal, para el desarrollo y crecimiento, el sentido de innovación.

El espíritu empresarial se basa en la integridad, la dedicación y el trabajo de equipo.

Hemos construido una respetada empresa líder a nivel regional, comprometida con el medio ambiente, dándole a los clientes tecnología de última generación y acompañándolos en todo el proceso de compra de una manera amena.



Aires del Sur - Electra

<http://www.electra.com.ar> info@electra.com.ar